

Your Ultimate Source for OEM Repair Manuals

FactoryManuals.net is a great resource for anyone who wants to save money on repairs by doing their own work. The manuals provide detailed instructions and diagrams that make it easy to understand how to fix a vehicle.

2024 Volvo C40 Service and Repair Manual

[Go to manual page](#)

Fig 3: Passenger Compartment Dimensions And Measurement Points (3 Of 4)

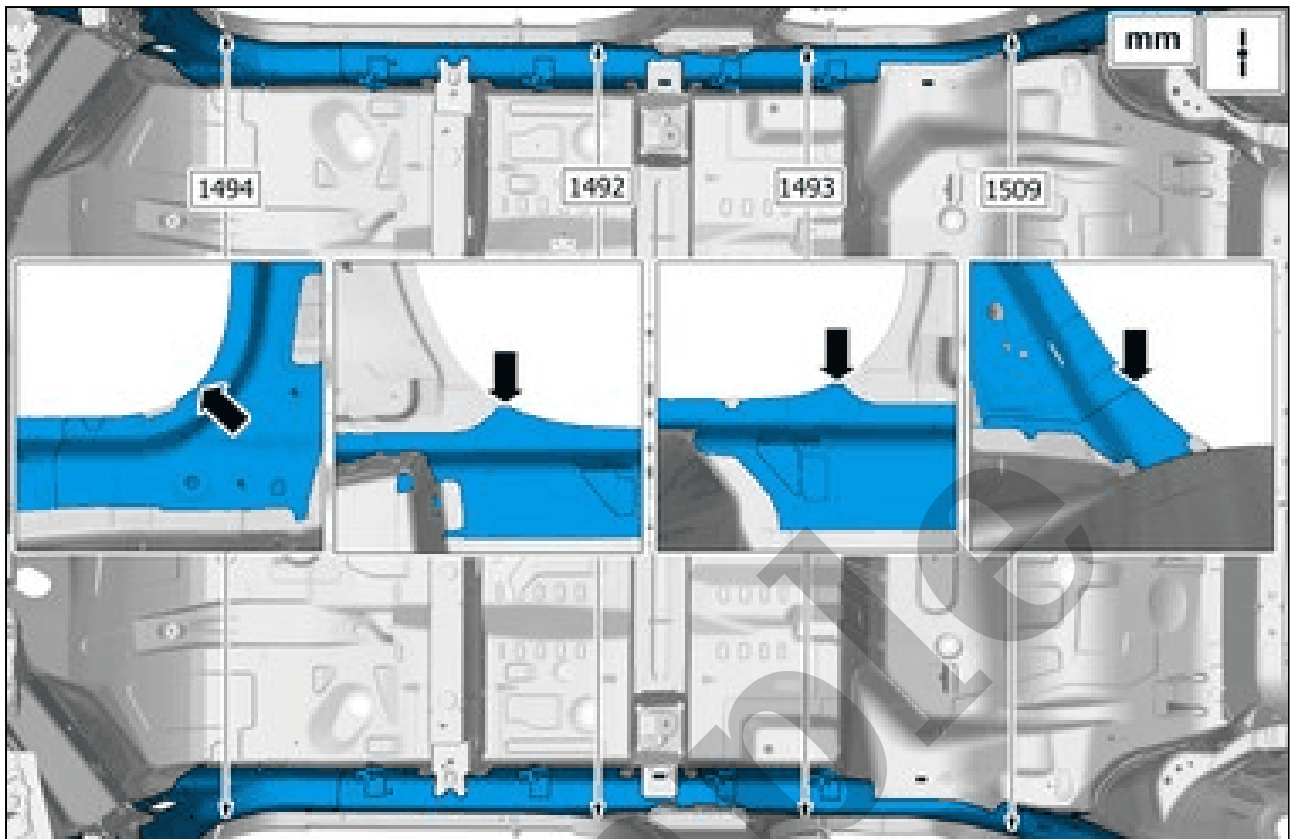

Courtesy of VOLVO CARS CORPORATION

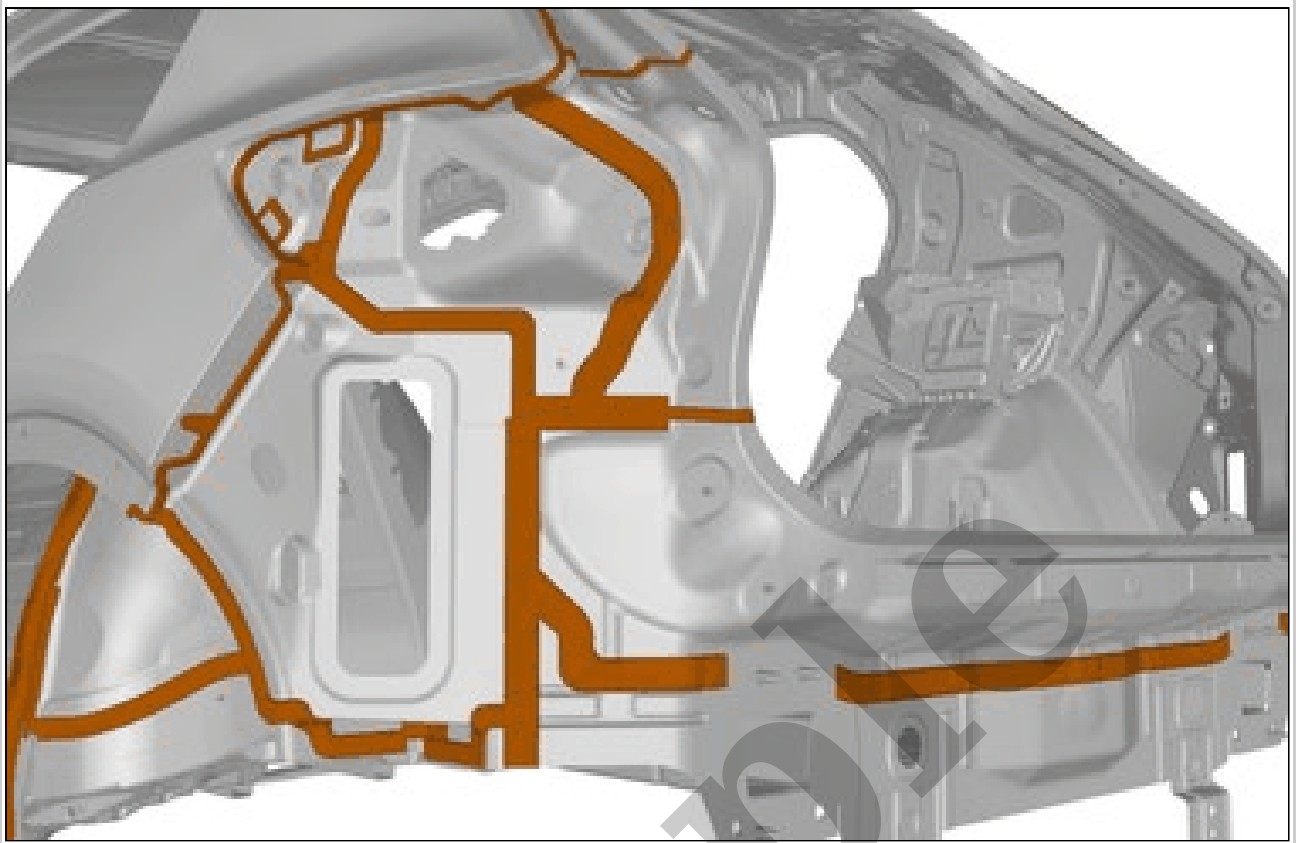

Courtesy of VOLVO CARS CORPORATION

Use: Sealing compound, 1161767

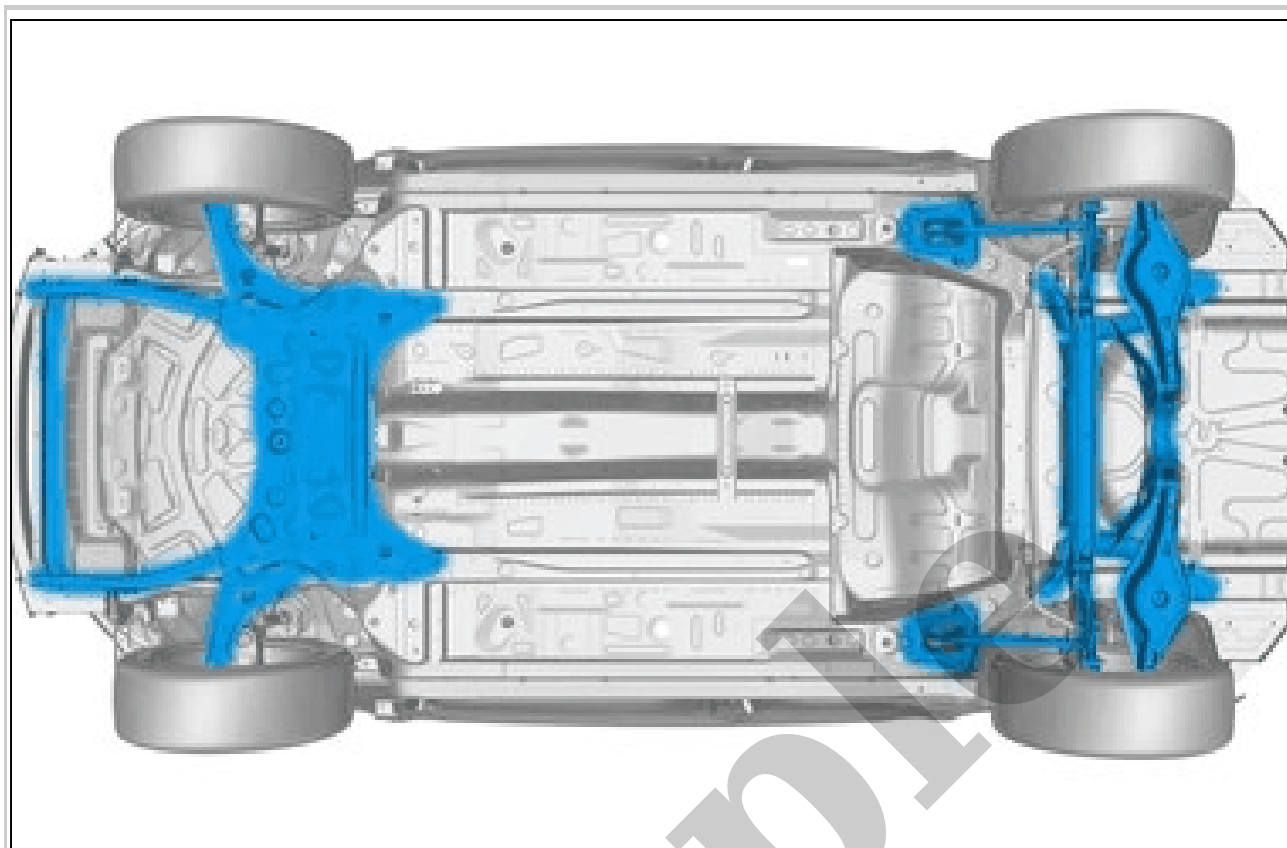

Courtesy of VOLVO CARS CORPORATION

Use: Underbody protection, 1161298
RUSTPROOFING SPECIAL TOOLS

Fig 4: Body Structure Identification Materials (4 Of 5)

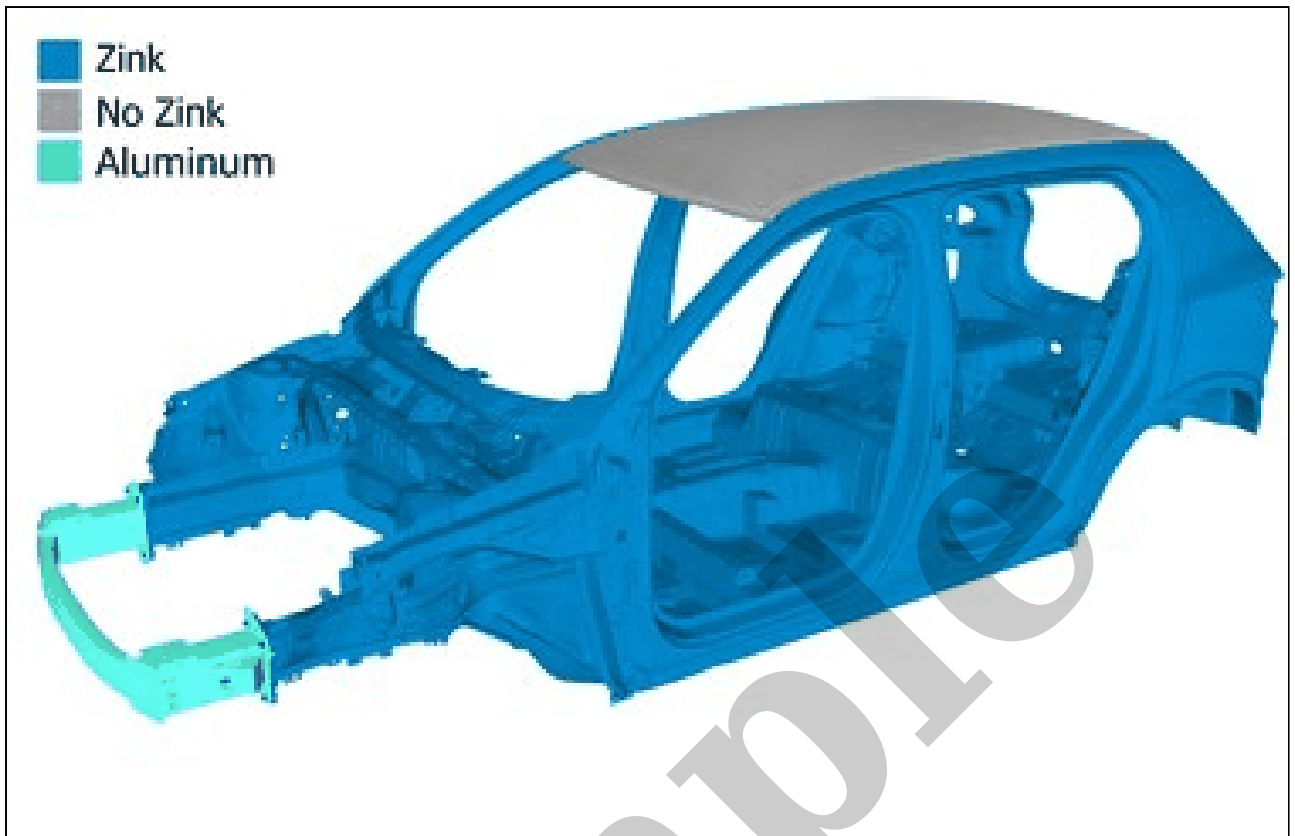

Courtesy of VOLVO CARS CORPORATION

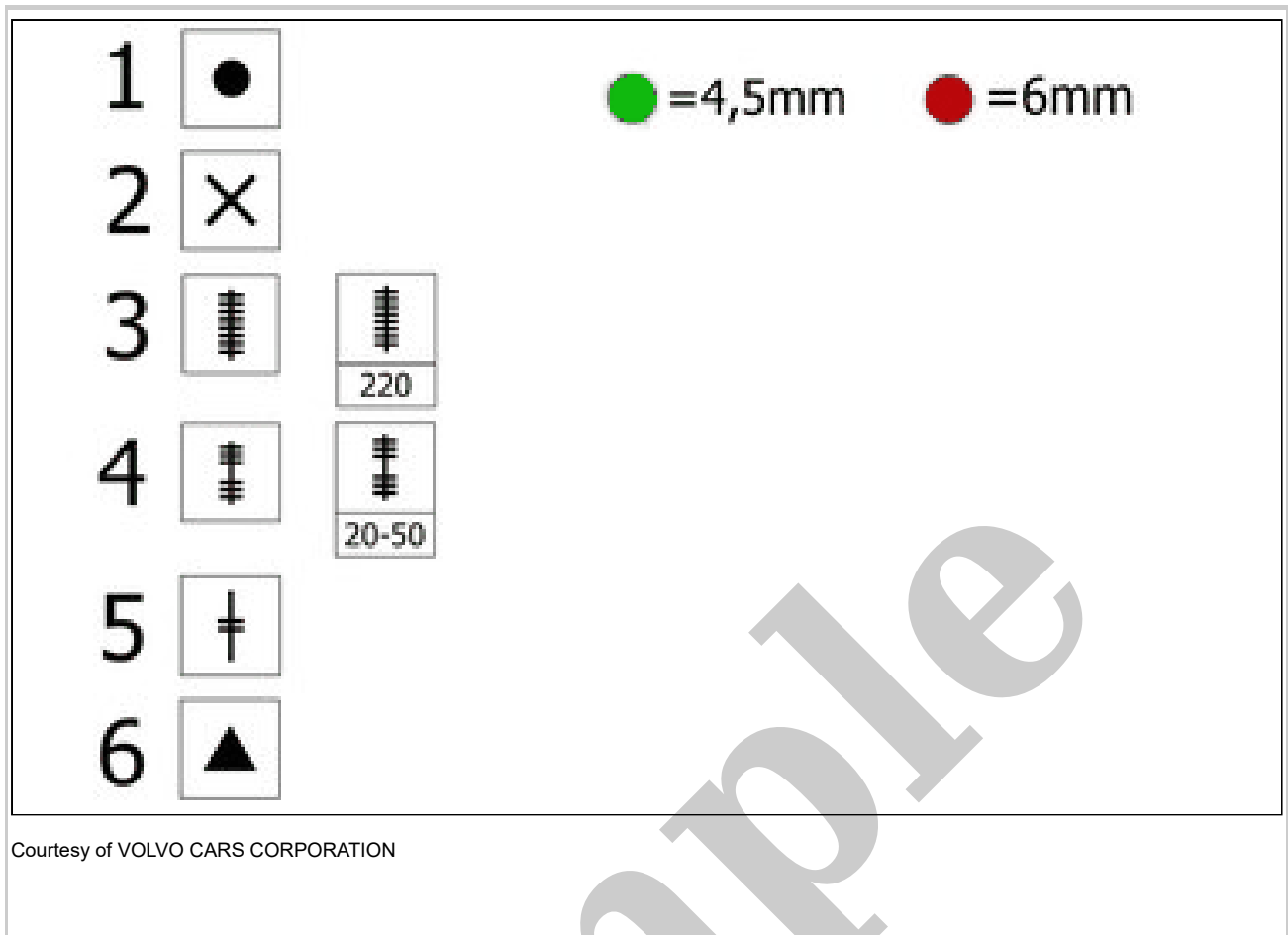

1. Spot weld/spot weld with the location of the weld and lens diameter specified with color (may be replaced with 2)
2. Plug weld (may be replaced with 1)
3. Seam weld/Seam weld with weld length specified in millimeters.
4. Step weld/Step weld with weld length followed by length between welds specified in millimeters. Always start and finish with the weld.
5. Tack weld
6. Glue

BODY CONSTRUCTION > [BODY REPAIR GENERAL WELDING] > GENERAL WELDING [2018, 2019, 2020, 2021, 2022] > RESISTANCE SPOT WELDING

Resistance spot welding must primarily be used if the capacity of the welding equipment is matched to panel thickness. When carrying out resistance spot welding, grind down to bare metal. Clean the surfaces with Scotch-Brite or similar to minimize zinc and phosphating damage. Apply welding primer between the panels. Always test weld according to the method below. Adjust the welding equipment for steel quality.

BODY COMPONENTS WITH DOUBLE-SIDED TAPE > COMPONENTS WITH DOUBLE-SIDED TAPE [2018, 2019, 2020, 2021, 2022] > INSTALLATION

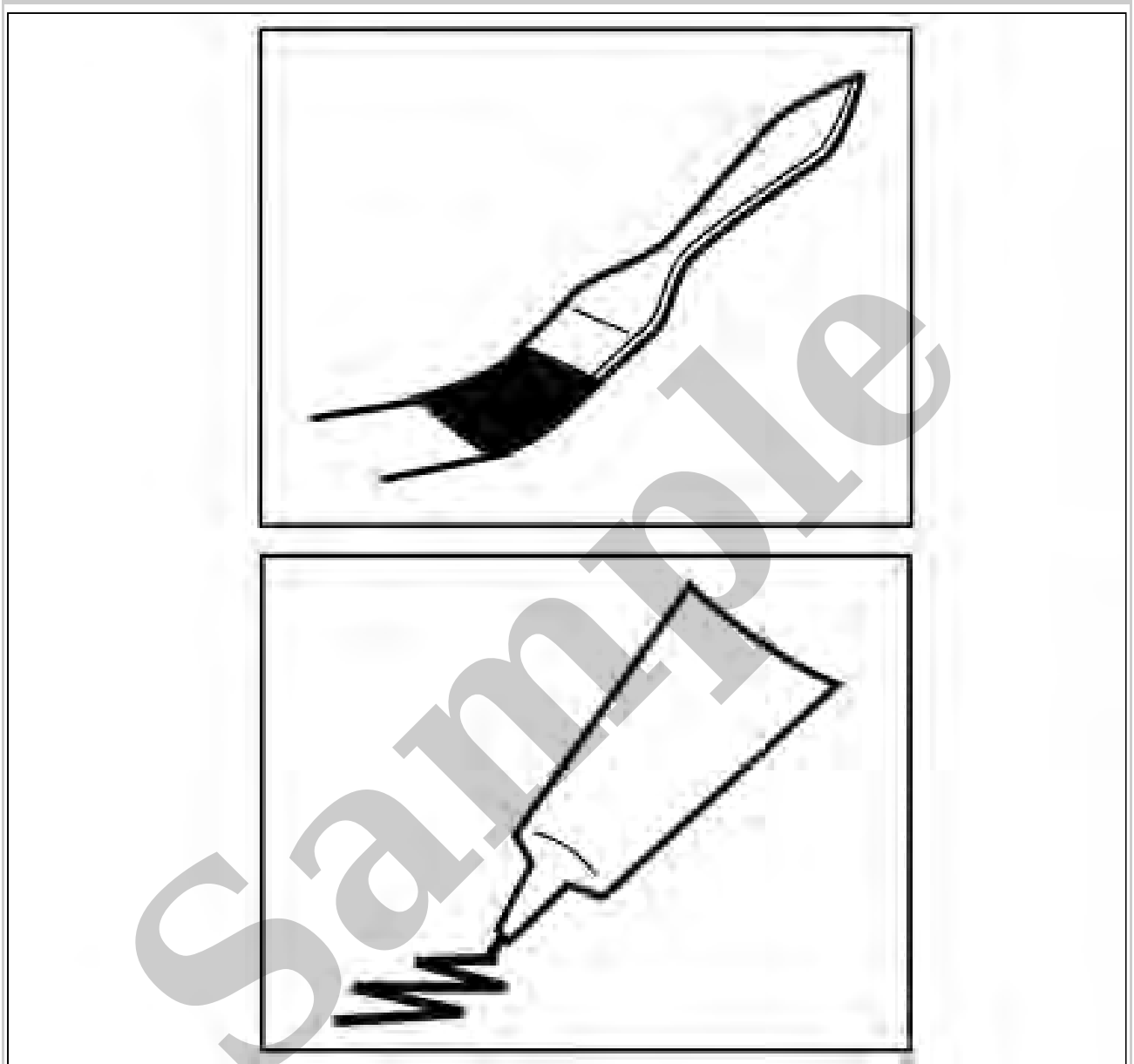

Courtesy of VOLVO CARS CORPORATION

NOTE: Apply a pressure of 35 - 50 N/cm² for 2-3 seconds. This corresponds to a thumb pressure of 3.5 - 5 kg - test with scales first. If the palm of a hand or an application roller is used, remember that the larger surface requires greater force.

Use: Applicator, 1161825

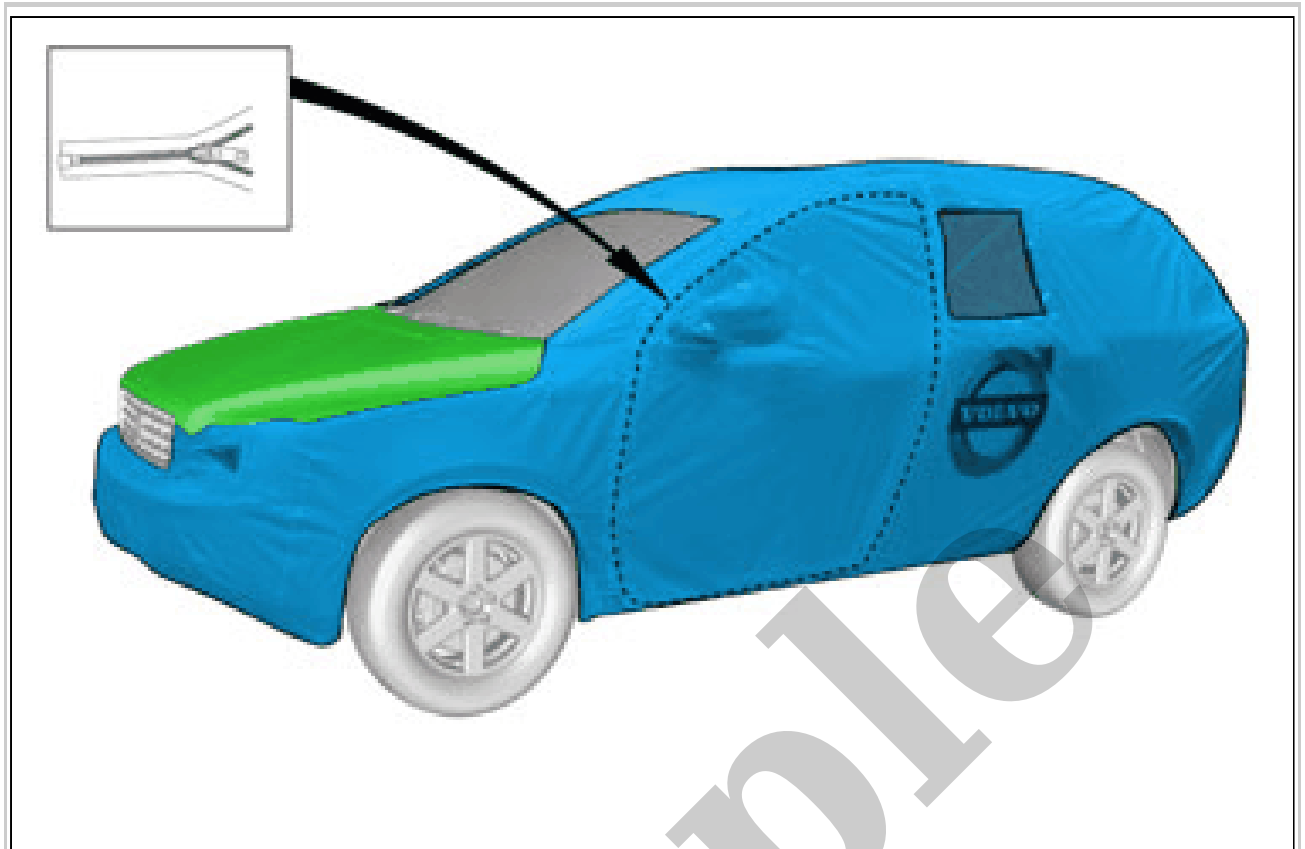

Courtesy of VOLVO CARS CORPORATION

Sample

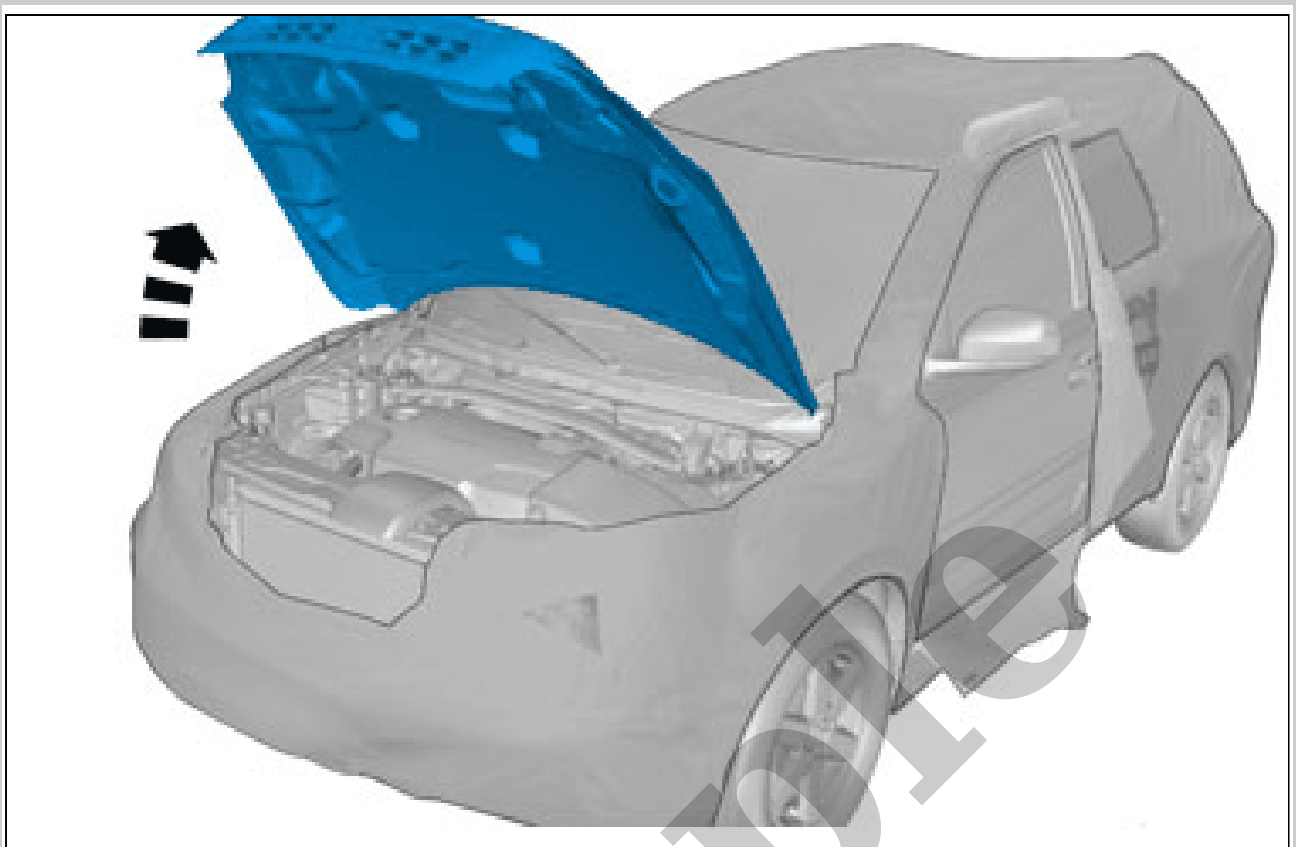

Courtesy of VOLVO CARS CORPORATION

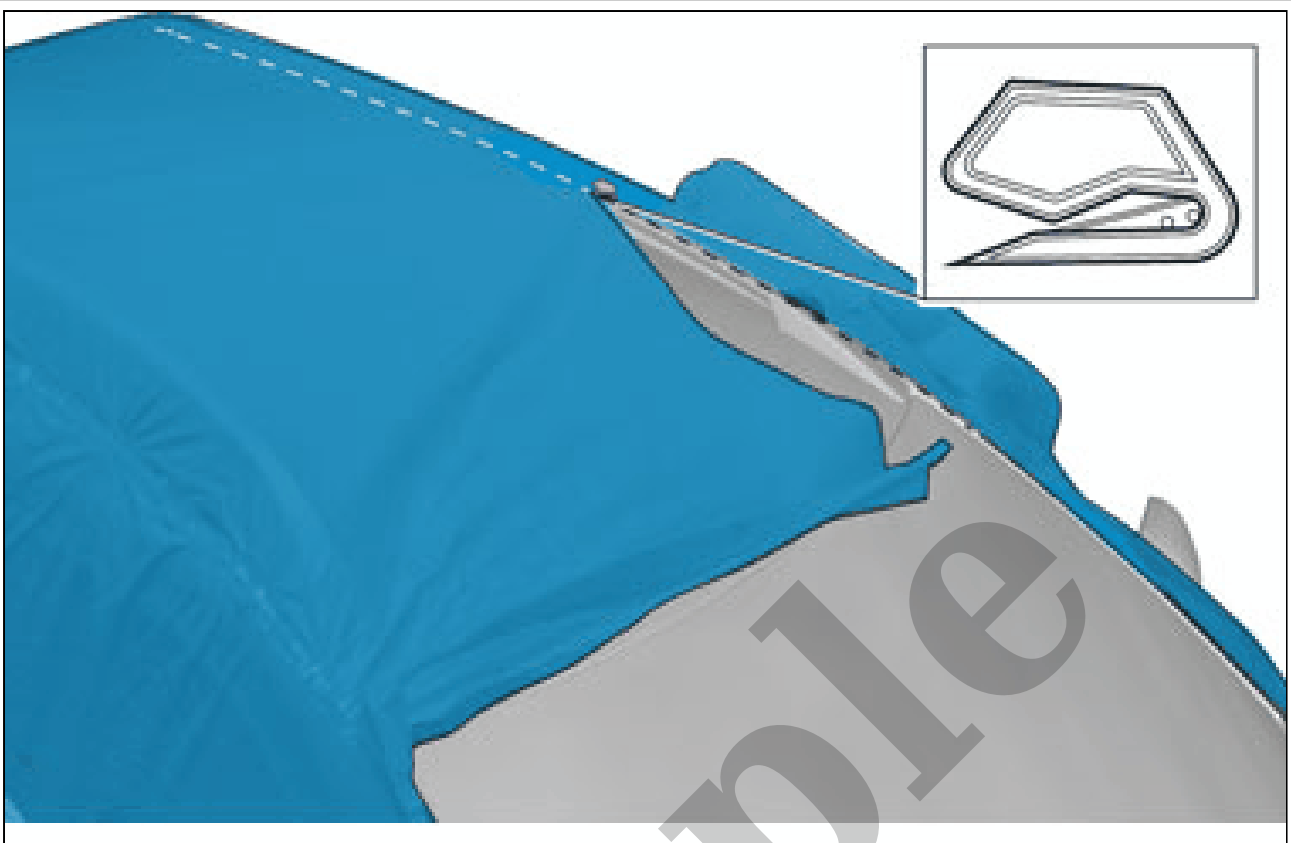

Courtesy of VOLVO CARS CORPORATION

Sample