

Your Ultimate Source for OEM Repair Manuals

FactoryManuals.net is a great resource for anyone who wants to save money on repairs by doing their own work. The manuals provide detailed instructions and diagrams that make it easy to understand how to fix a vehicle.

2024 Toyota Rav4 Service Manual

[Go to manual page](#)

*1	FRONT BUMPER ASSEMBLY	*2	FRONT FENDER LINER LH
*3	FRONT FENDER LINER RH	*4	HOOD TO RADIATOR SUPPORT SEAL
*5	FRONT FENDER UPPER PROTECTOR LH	*6	FRONT FENDER UPPER PROTECTOR RH
*7	FASTENER	-	-
	N*m (kgf*cm, ft.*lbf): Specified torque	•	Non-reusable part

ILLUSTRATION

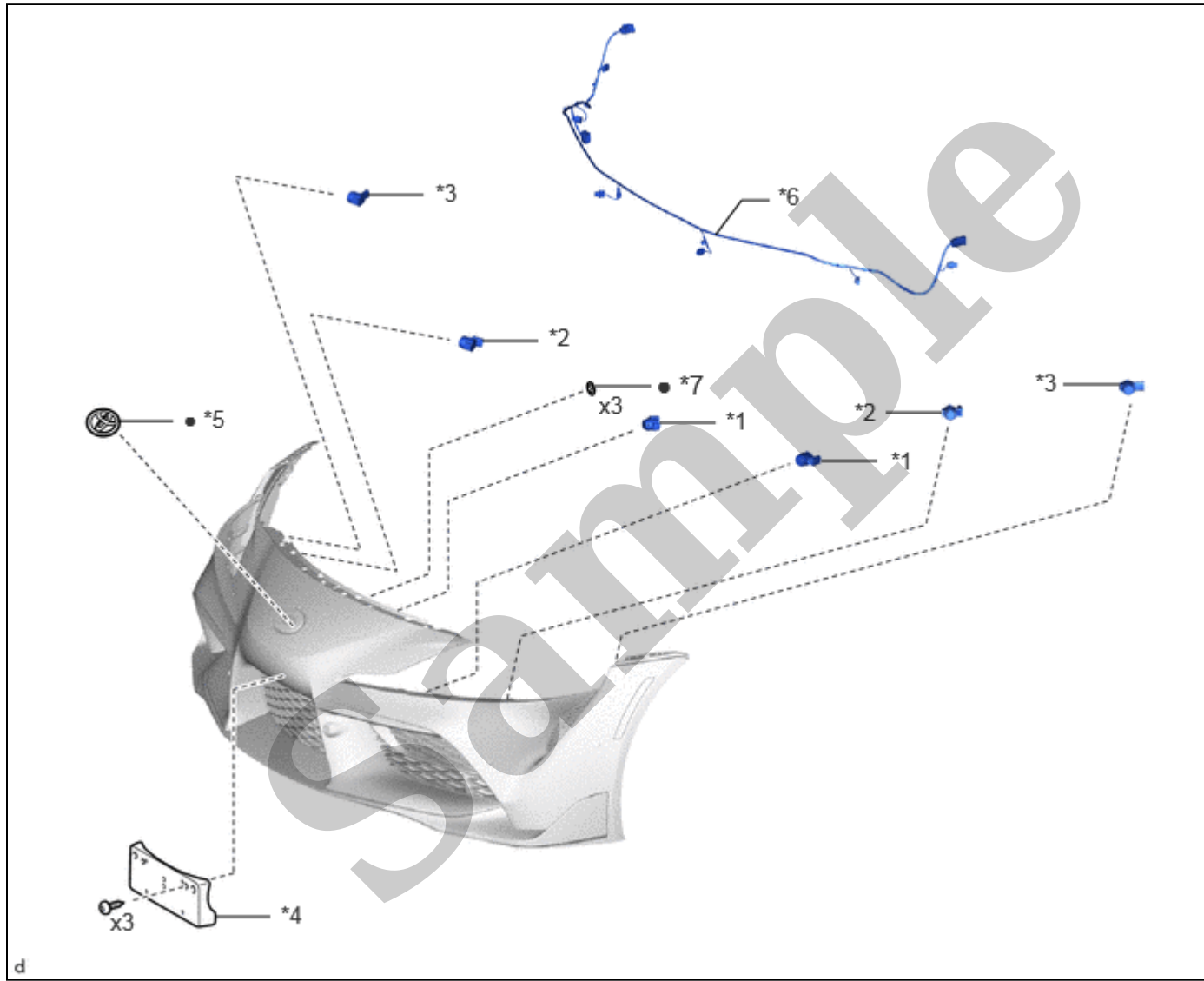

*1	FRONT CENTER ULTRASONIC SENSOR	*2	FRONT CORNER ULTRASONIC SENSOR
*3	FRONT SIDE ULTRASONIC SENSOR	*4	FRONT BUMPER EXTENSION MOUNTING BRACKET
*5	FRONT BUMPER EMBLEM SUB-ASSEMBLY	*6	NO. 4 ENGINE ROOM WIRE
*7	SPRING NUT	-	-
•	Non-reusable part	-	-

ILLUSTRATION

*11	LOWER RADIATOR GRILLE RH	*12	LOWER SIDE RADIATOR GRILLE RH
*13	MILLIMETER WAVE RADAR SENSOR ASSEMBLY	*14	REFLEX REFLECTOR ASSEMBLY LH
*15	REFLEX REFLECTOR ASSEMBLY RH	*16	NUT
*a	Front Bumper Side Retainer for Repair	-	-
	N*m (kgf*cm, ft.*lbf): Specified torque	•	Non-reusable part

ILLUSTRATION

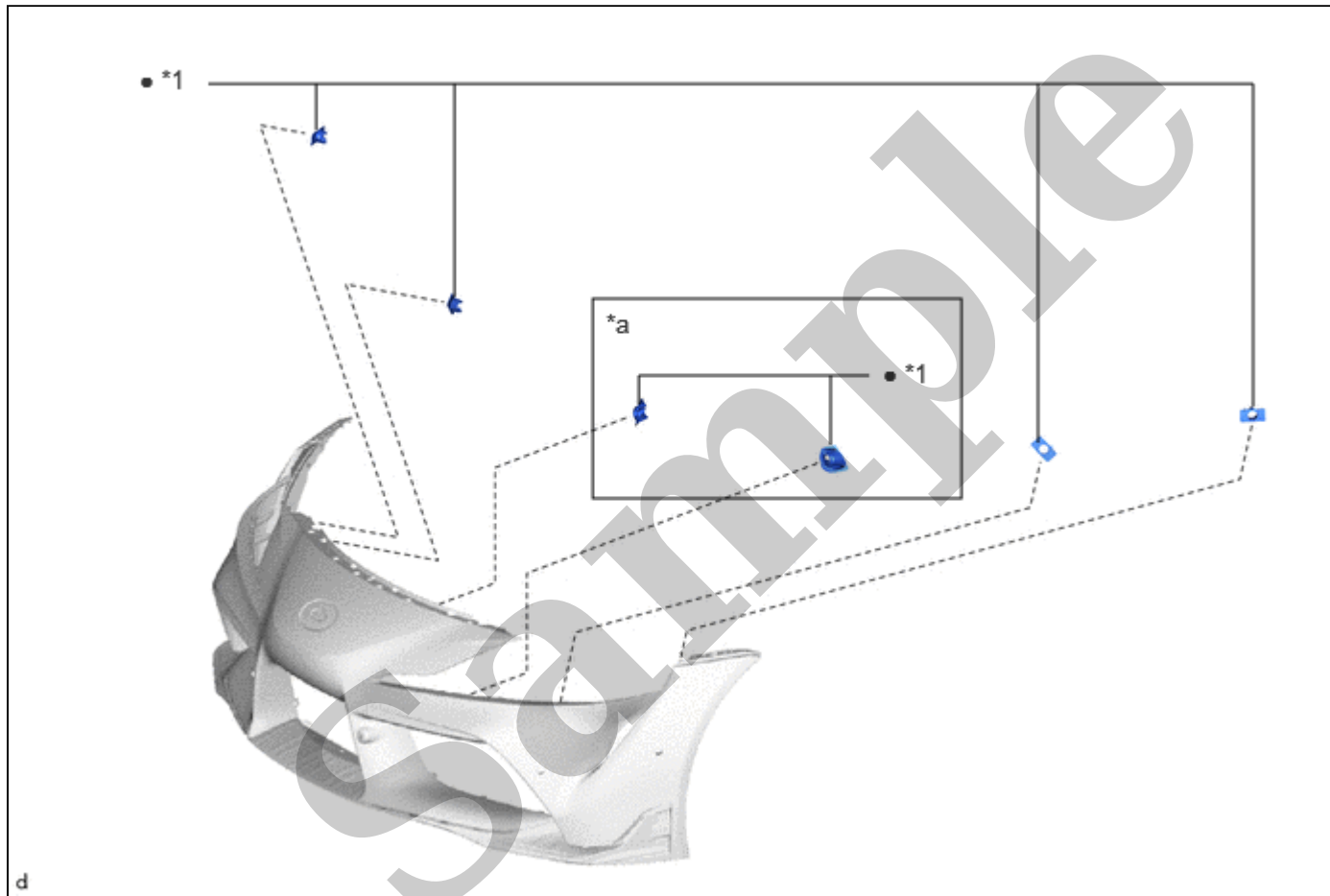

*1	NO. 1 ULTRASONIC SENSOR RETAINER	-	-
*a	The No. 1 ultrasonic sensor retainer of the front center ultrasonic sensor is welded to the front bumper assembly and cannot be removed.	-	-
•	Non-reusable part	-	-

ILLUSTRATION

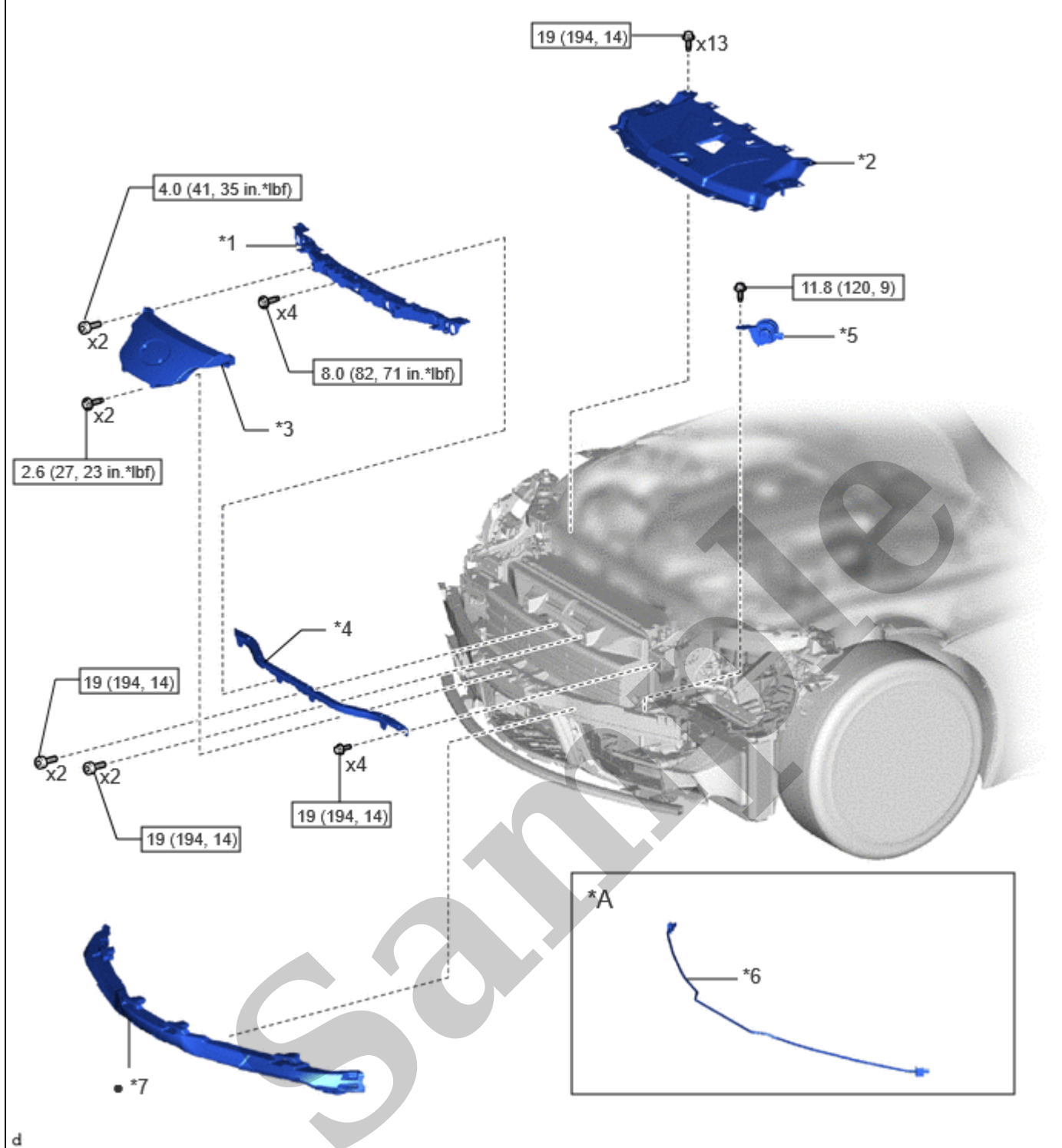

d

*A	w/ Pedestrian Detection Chamber Assembly	-	-
*1	FRONT BUMPER UPPER RETAINER	*2	RADIATOR UPPER AIR DEFLECTOR
*3	FRONT BUMPER INNER SUPPORT	*4	FRONT CROSSMEMBER
*5	HIGH PITCHED HORN ASSEMBLY	*6	PEDESTRIAN DETECTION CHAMBER ASSY
*7	FRONT BUMPER ENERGY ABSORBER	-	-
	N*m (kgf*cm, ft.*lbf): Specified torque	•	Non-reusable part

ILLUSTRATION

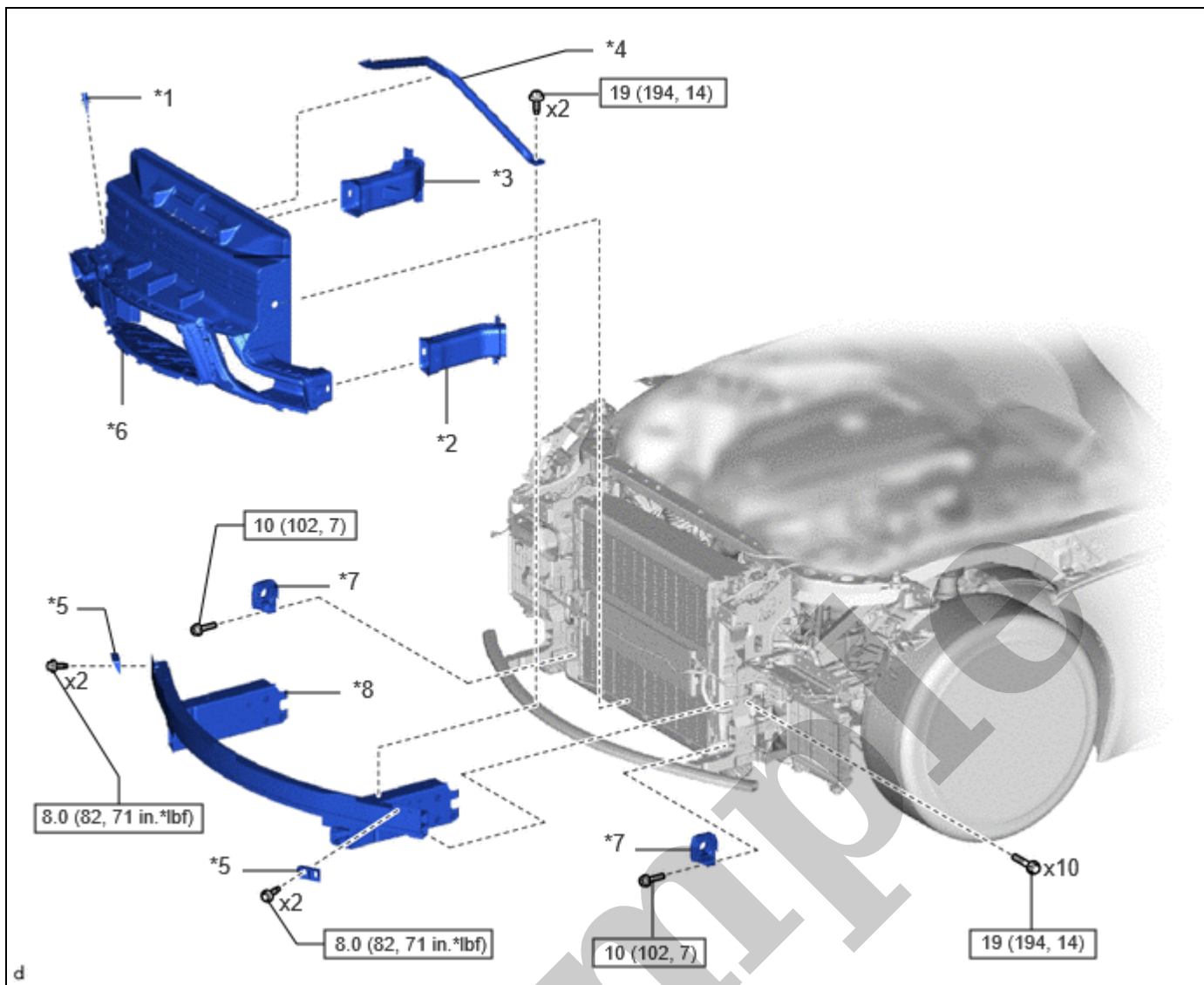

*1	TEMPERATURE SENSOR ASSEMBLY	*2	AIR INTAKE DUCT LH
*3	AIR INTAKE DUCT RH	*4	RADIATOR BRACE ROD SUB-ASSEMBLY
*5	FRONT BUMPER SIDE SUPPORT	*6	NO. 1 COOL AIR INTAKE DUCT
*7	BOTTOM COOLER MODULE MOUNT	*8	FRONT BUMPER REINFORCEMENT
	N*m (kgf*cm, ft.*lbf): Specified torque	-	-

ILLUSTRATION