

Your Ultimate Source for OEM Repair Manuals

FactoryManuals.net is a great resource for anyone who wants to save money on repairs by doing their own work. The manuals provide detailed instructions and diagrams that make it easy to understand how to fix a vehicle.

2024 Nissan Pathfinder Service and Repair Manual

[Go to manual page](#)

DANGER:

Since hybrid vehicles and electric vehicles contain a high voltage battery, there is the risk of electric shock, electric leakage, or similar accidents resulting in death or severe injury, if high voltage components and vehicle are mishandled. When performing an inspection or maintenance, be sure to comply with the instructions below to perform correct work procedures.

WARNING:

- Be sure to remove the service plug in order to disconnect the high voltage circuits before performing inspection or maintenance of high voltage system harnesses and parts.
- The removed service plug must always be carried in a pocket of the responsible worker or placed in the tool box during the procedure to prevent the plug from being connected by mistake.
- Be sure to wear insulated protective equipment before beginning work on the high voltage system.
- Never allow workers other than the responsible person to touch the vehicle containing high voltage parts. To keep others from touching the high voltage parts, these parts must be covered with an insulating sheet except when using them.

CAUTION:

- Be sure to install the high voltage harness clips to the original positions to prevent damage to high voltage harness. If the clips are damaged, replace them with new ones before installing the high voltage harness.
- To prevent damage to parts, never allow coolant to splash on the high voltage harness connector. If coolant splashes on the high voltage harness connector, immediately remove moisture from the high voltage harness connector by using an air blow gun.
- Never bring the vehicle into the READY status with the service plug removed unless otherwise instructed in the Service Manual. A malfunction may occur if this is not observed.

POINT TO BE CHECKED BEFORE STARTING MAINTENANCE WORK

The high voltage system may start automatically. It is required to check that the charge cable (including EVSE) is not connected to charge port before starting maintenance work.

**NOTE:**

If the timer air conditioner or timer charge is set when the EVSE is connected, the high voltage system starts automatically even when the power switch is in OFF state.

HIGH VOLTAGE HARNESS AND EQUIPMENT IDENTIFICATION

All the high voltage harnesses and connectors are orange. The Li-ion battery and other high voltage devices include an orange high voltage label. Never touch these harnesses and high voltage parts.

HANDLING OF HIGH VOLTAGE HARNESS AND TERMINALS

Immediately insulate disconnected high voltage connectors and terminals with insulating tape.

GUIDELINES ON WORKERS WITH MEDICAL ELECTRONICS

WARNING:

The vehicle contains parts that contain powerful magnets. If a person who is wearing a heart pacemaker or other medical device is close to these parts, the medical device may be affected by the magnets. Such persons must not perform work on

the vehicle.

PROHIBITED ITEMS TO CARRY DURING THE WORK

Hybrid vehicles and electric vehicles contain parts with high voltage and intense magnetic force. Never carry metal products and magnetic recording media (e.g. credit card, debit card) to repair/inspect high voltage parts. If this is not observed, the metal products may create a risk of short circuit and the magnetic recording media may lose their magnetic recording.

POST A SIGN OF “DANGER! HIGH VOLTAGE AREA. KEEP OUT”

Call the attention of other workers and indicate "High voltage work in progress." Do not touch vehicles where work is being performed on high voltage systems.

Sample

Person in charge: _____

**DANGER:
HIGH VOLTAGE
REPAIR IN PROGRESS.
DO NOT TOUCH!**

**DANGER:
HIGH VOLTAGE
REPAIR IN PROGRESS.
DO NOT TOUCH!**

Person in charge: _____

Copy this page and put it after folding on the roof of the vehicle in service.

RDE-001937880-01-SAIA1600GB

Precautions for Removing Battery Terminal

RDE-001934135

- With the adoption of Auto ACC function, ACC power is automatically supplied by operating the Intelligent Key or remote keyless entry or by opening/closing the driver side door. In addition, ACC power is supplied even after the ignition switch is turned to the OFF position, i.e. ACC power is supplied for a certain fixed time.
- When disconnecting the 12V battery terminal, turn off the ACC power before disconnecting the 12V battery terminal, observing “How to disconnect 12V battery terminal” described below.

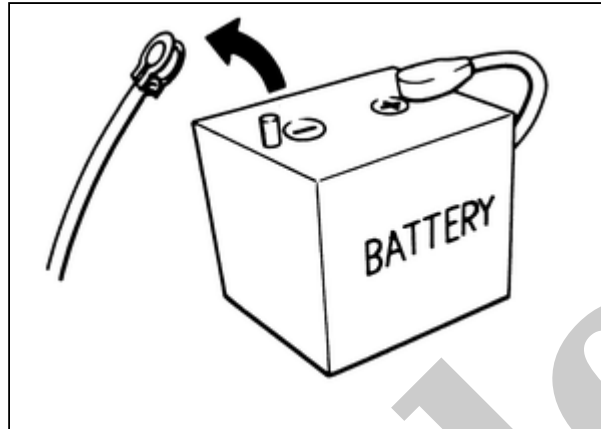

RDE-001934135-01-EF289H



NOTE:

ECU may be active for several minutes after the power switch is turned OFF. If the battery terminal is removed before ECU stops, then a DTC detection error or ECU data corruption may occur.

- Disconnect 12V battery terminal according to the following steps. Even when the power switch is OFF, the 12V battery automatic charge control may automatically start.

CAUTION:

Do not remove the battery during the update as the software update cannot be completed normally if the battery is removed during the software update.

WORK PROCEDURE

1. Open the hood (LHD models) or the back door (RHD models).
2. Check that charge cable (including EVSE) is not connected to the charge port.



NOTE:

If charge cable (including EVSE) is connected, the air conditioning system may be automatically activated by the timer A/C function.

3. Turn the power switch OFF → ON → press the power switch for at least 2 seconds to turn the high voltage system OFF, and then check that the charging status indicator is not illuminated.



NOTE:

When the high voltage system is turned ON, the charging status indicator blinks green with a frequency of 1 second.

4. Get out of the vehicle. Close all doors {except the hood (LHD models) or the back door (RHD models)}.
5. Check that the combination meter turns OFF and wait for 5 minutes or more.

CAUTION:

While waiting, never operate the vehicle such as locking, opening, and closing doors. Violation of this caution results in the activation of ACC power supply according to the Auto ACC function.



NOTE:

If the battery is removed within 5 minutes after the power switch is turned OFF, plural DTCs may be detected.

6. Check that the followings are not illuminated.

- Charging status indicator
- Electric parking brake warning lamp

7. Remove 12V battery terminal within 60 minutes after the power switch is turned OFF at Step 3.

CAUTION:

- **After all doors (including hood and back door) are closed, if a door (including hood and back door) is opened before battery terminals are disconnected, start over from Step 3.**
- **After turning the power switch OFF, if “Remote A/C” is activated by user operation, stop the air conditioner and start over from Step 3.**



NOTE:

Once the power switch is turned ON → OFF, the 12V battery automatic charge control does not start for approximately 1 hour.

- For vehicles with the 2-batteries, be sure to connect the main battery and the sub battery before turning ON the power switch.



NOTE:

If the power switch is turned ON with any one of the terminals of main battery and sub battery disconnected, then DTC may be detected.

- After installing the 12V battery, always check "Self Diagnosis Result" of all ECUs and erase DTC.







NOTE:

The removal of 12V battery may cause a DTC detection error.

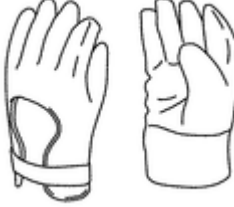
Common Service Tools

RDE-001937878

Tool name		Description
<p>Insulated gloves</p> <p>[Guaranteed insulation performance for 1000V/300A]</p>	 <p>RDE-001937878-01-MCIA0149ZZ</p>	<p>Removing and installing high voltage components</p>
<p>Leather gloves</p> <p>[Use leather gloves that can fasten the wrist tight]</p>	 <p>RDE-001937878-02-PCIA0066ZZ</p>	<ul style="list-style-type: none"> • Removing and installing high voltage components • Protect insulated gloves
<p>Insulated safety shoes</p>	 <p>RDE-001937878-03-PCIA0011ZZ</p>	<p>Removing and installing high voltage components</p>
<p>Safety glasses</p> <p>[ANSI Z87.1]</p>	 <p>RDE-001937878-05-PCIA0012ZZ</p>	<ul style="list-style-type: none"> • Removing and installing high voltage components • To protect eye from the spatter on the work to electric line
<p>Face shield</p>	 <p>RDE-001937878-04-PCIA0167ZZ</p>	<ul style="list-style-type: none"> • Removing and installing high voltage components • To protect face from the spatter on the work to electric line

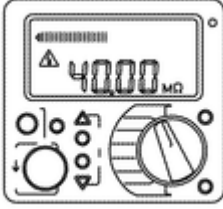
Tool name		Description
Insulated helmet	 <p>RDE-001937878-06-PCIA0013ZZ</p>	Removing and installing high voltage components
Insulation resistance tester (Multi tester)	 <p>RDE-001937878-08-PCIA0014ZZ</p>	Measuring insulation resistance, voltage, and resistance

Sample

WARNING:

Since hybrid vehicles and electric vehicles contain a high voltage battery, there is the risk of electric shock, electric leakage, or similar accidents if the high voltage component and vehicle are handled incorrectly. Be sure to follow the correct work procedures when performing inspection and maintenance.

WARNING:

- Be sure to remove the service plug in order to disconnect the high voltage circuits before performing inspection or maintenance of high voltage system harnesses and parts.
- The removed service plug must always be carried in a pocket of the responsible worker or placed in the tool box during the procedure to prevent the plug from being connected by mistake.
- Be sure to wear insulating protective equipment consisting of glove, shoes, face shield and glasses before beginning work on the high voltage system.
- Never allow workers other than the responsible person to touch the vehicle containing high voltage parts. To keep others from touching the high voltage parts, these parts must be covered with an insulating sheet except when using them.
- Refer to [Precautions for High Voltage](#).

CAUTION:

Never bring the vehicle into the READY status with the service plug removed unless otherwise instructed in the Service Manual. A malfunction may occur if this is not observed.

DIAGNOSIS PROCEDURE

1. PRECONDITIONING

WARNING:

Follow the instructions below before starting the procedure.

1. Disconnect high voltage circuit. Refer to [HOW TO DISCONNECT HIGH VOLTAGE : Precautions](#).
2. Check voltage in high voltage circuit. Refer to [CHECK VOLTAGE IN HIGH VOLTAGE CIRCUIT : Precautions](#).

>>

[GO TO 2.](#)

2. CHECK PTC HEATER INSULATION RESISTANCE

1. Disconnect high voltage harness connector from PTC heater.
2. Check the insulation resistance of the PTC heater with an insulation resistance tester.

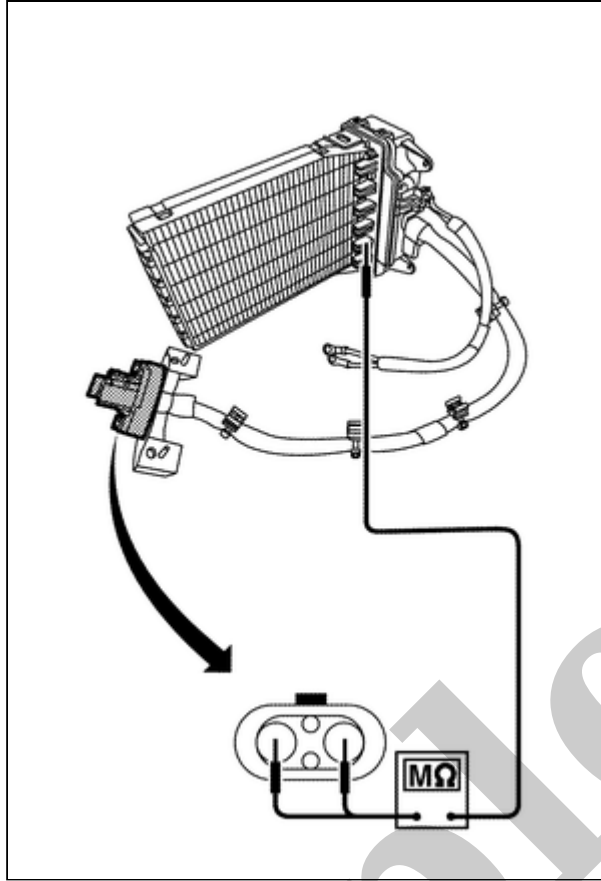

SIEMD-7206806-01-000369515

CAUTION:

- Unlike the ordinary tester, the insulation resistance tester applies 500V when measuring. If used incorrectly, there is the danger of electric shock. If used in the vehicle 12V system, there is the danger of damage to electronic devices. Read the insulation resistance tester instruction manual carefully and be sure to work safely.
- Use 500V range of insulation resistance tester to measure insulation resistance. Wait for 30 seconds until the value becomes stable.

+		
PTC heater Terminal	-	Resistance
1	Aluminum part of PTC heater	20 MΩ or more
2		

Is the inspection result normal?

YES>>

INSPECTION END

NO>>

Replace PTC heater. Refer to [Removal & Installation](#).