

Your Ultimate Source for OEM Repair Manuals

FactoryManuals.net is a great resource for anyone who wants to save money on repairs by doing their own work. The manuals provide detailed instructions and diagrams that make it easy to understand how to fix a vehicle.

2023 Toyota Corolla Service and Repair Manual

[Go to manual page](#)

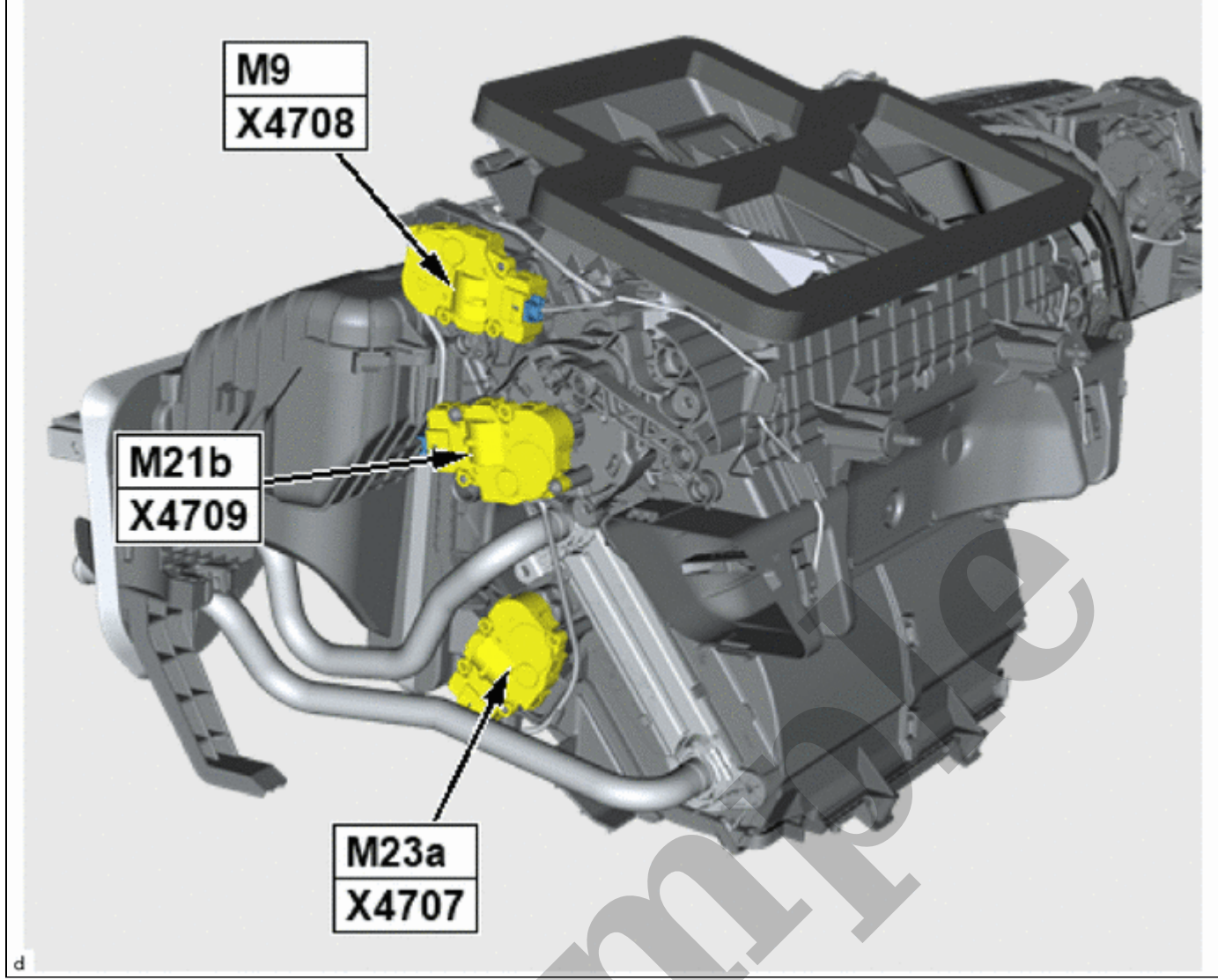

(a) Disconnect the connector (1).

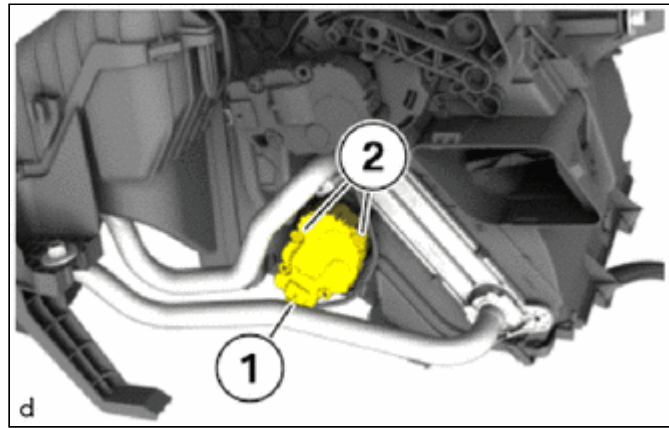

(b) Remove T20 screws (2).

(c) Remove No. 1 air conditioning radiator damper servo sub-assembly (M23a).

16. REMOVE NO. 1 AIR CONDITIONING RADIATOR DAMPER SERVO SUB-ASSEMBLY (M83a)

HINT:

Overview of No. 1 air conditioning radiator damper servo sub-assembly of air conditioning unit assembly:

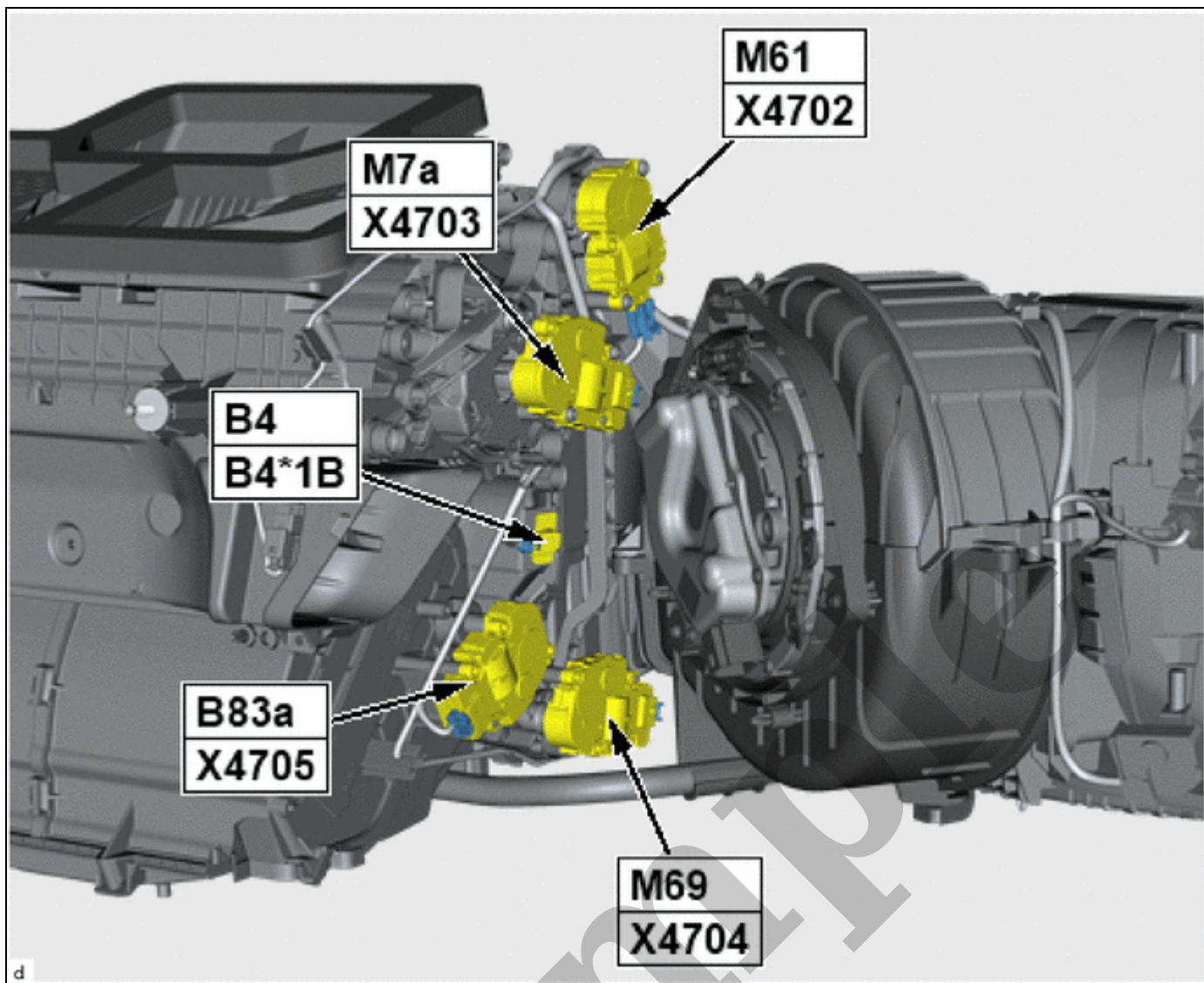

(a) Disconnect the connector (1).

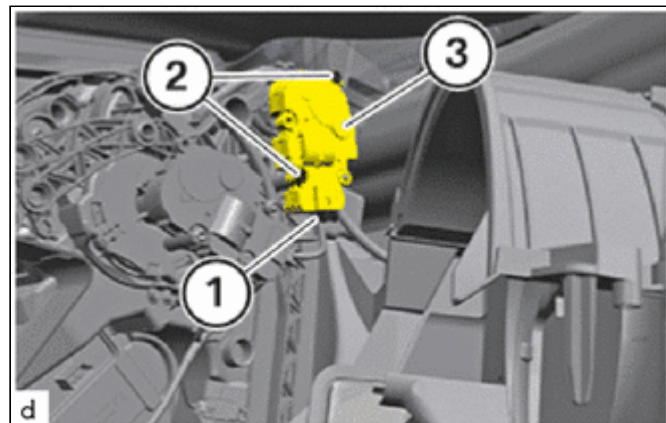

(b) Remove T20 screws (2).

(c) Remove No. 1 air conditioning radiator damper servo sub-assembly (M61) (3).

19. REMOVE NO. 1 AIR CONDITIONING RADIATOR DAMPER SERVO SUB-ASSEMBLY (M7a)

HINT:

Overview of No. 1 air conditioning radiator damper servo sub-assembly of air conditioning unit assembly:

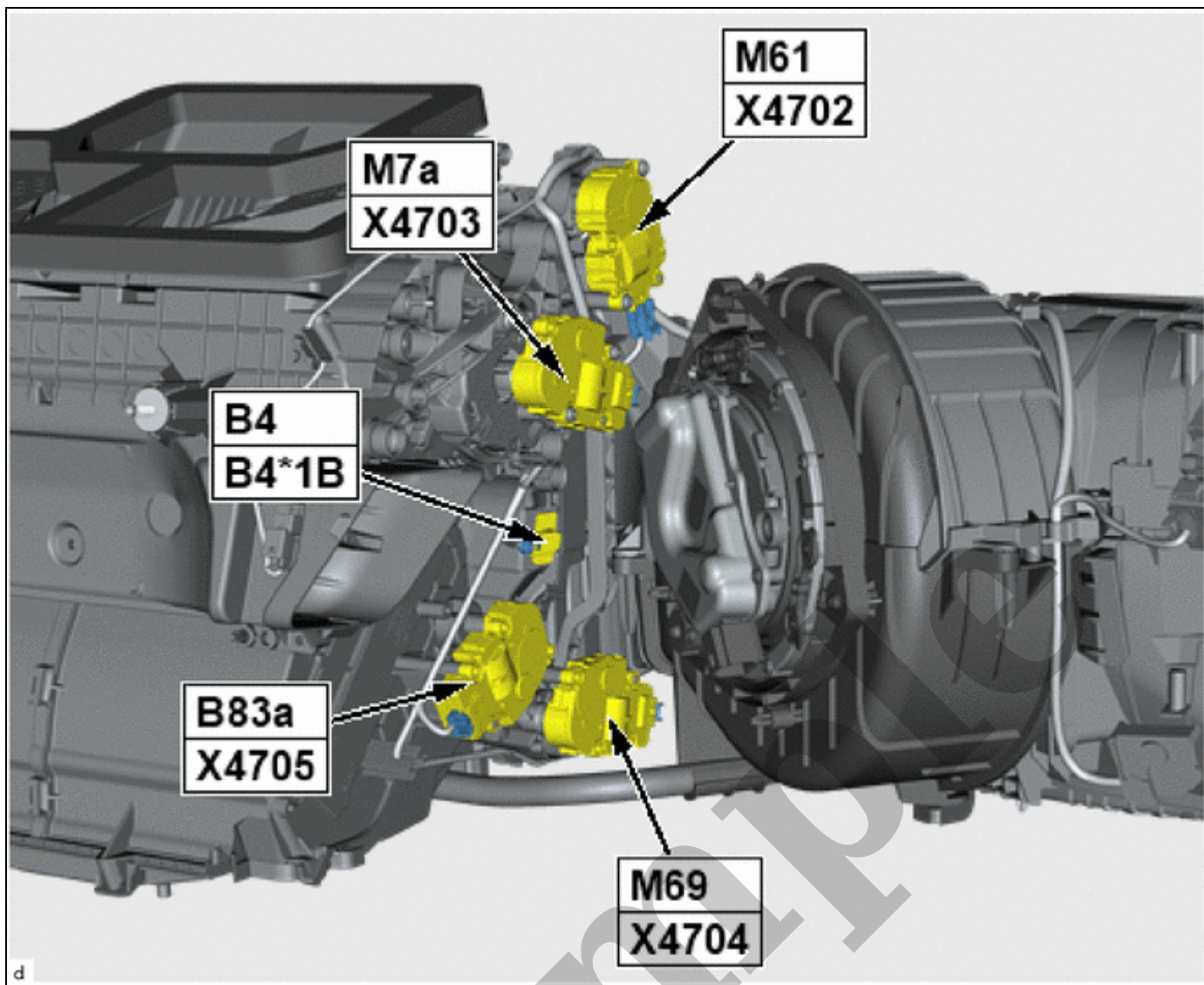

(a) Disconnect the connector (2).

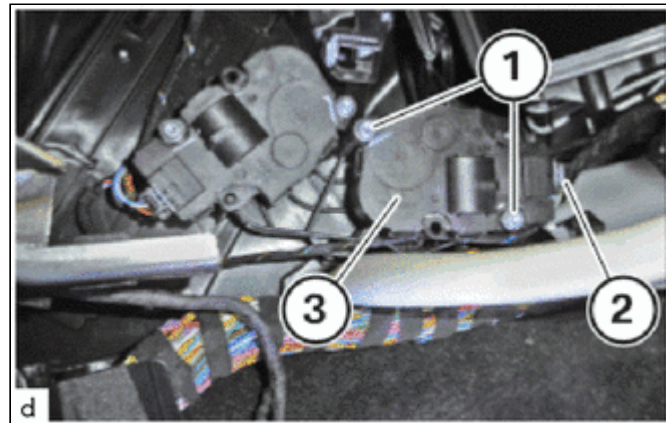

(b) Remove T20 screws (1).

(c) Remove No. 1 air conditioning radiator damper servo sub-assembly (M69) (3).

21. REMOVE NO. 1 INSTRUMENT PANEL GARNISH SUB-ASSEMBLY

Click here [INFO](#)

22. REMOVE GLOVE COMPARTMENT DOOR ASSEMBLY

Click here [INFO](#)

25. REMOVE NO. 1 AIR CONDITIONING RADIATOR DAMPER SERVO SUB-ASSEMBLY (M21b)

HINT:

Overview of No. 1 air conditioning radiator damper servo sub-assembly of air conditioning unit assembly:

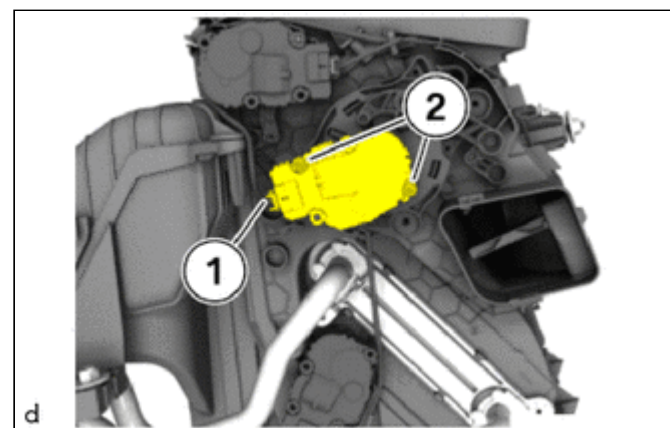
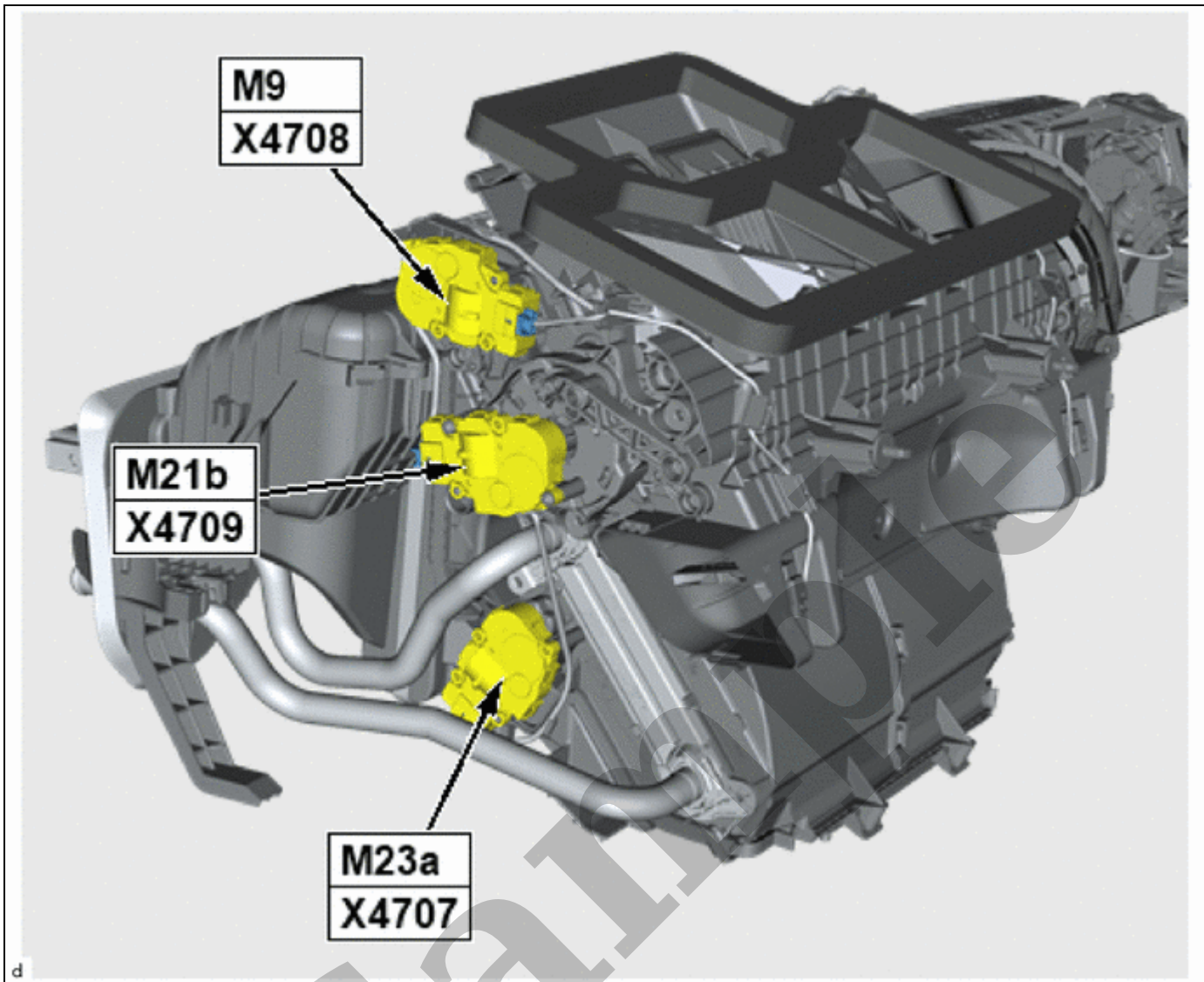

(a) Disconnect the connector (1).

(b) Remove T20 screws (2).

(c) Remove No. 1 air conditioning radiator damper servo sub-assembly (M21b).

26. REMOVE RADIO RECEIVER ASSEMBLY (w/o Navigation System)

Click here [INFO](#)