

Your Ultimate Source for OEM Repair Manuals

FactoryManuals.net is a great resource for anyone who wants to save money on repairs by doing their own work. The manuals provide detailed instructions and diagrams that make it easy to understand how to fix a vehicle.

Volvo XC40 2021 Manual - Service & Repair Workshop Guide

[Go to manual page](#)

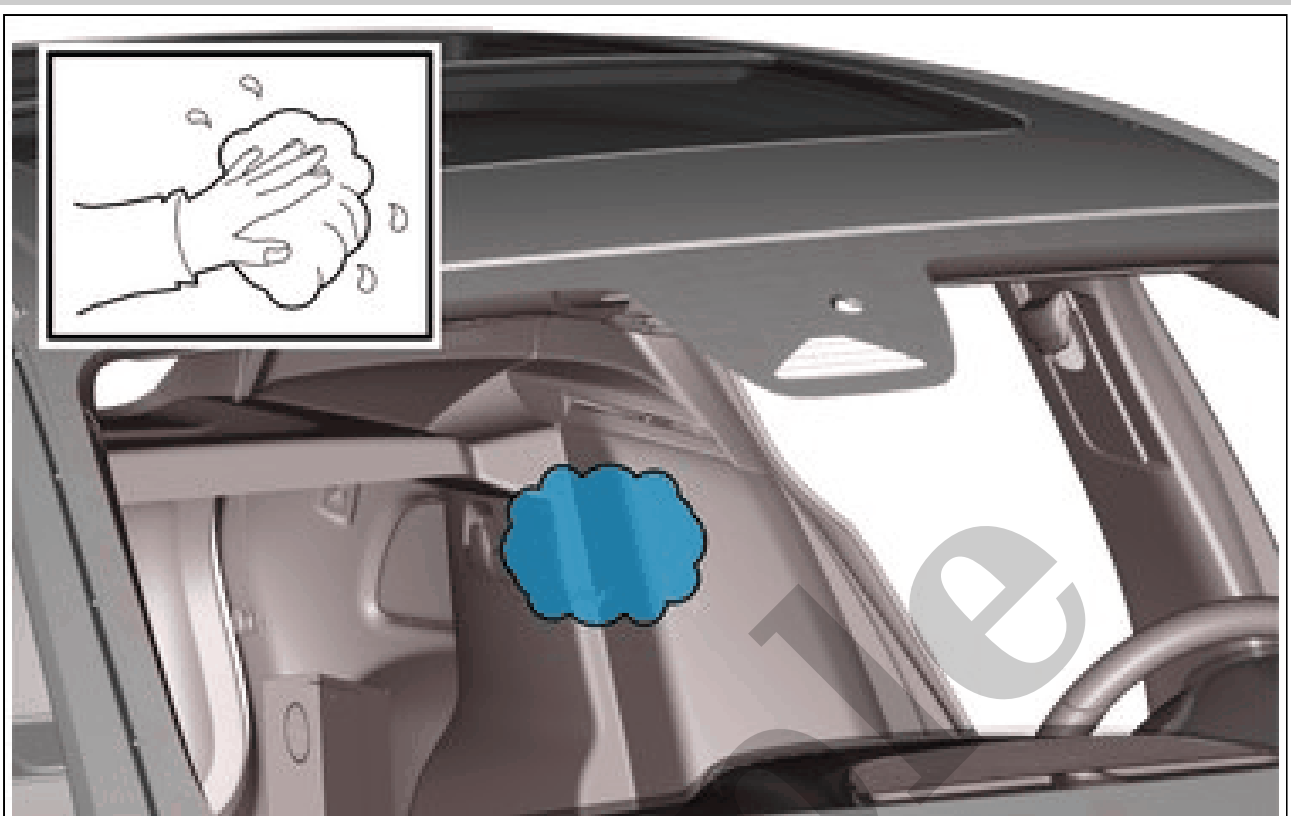

Courtesy of VOLVO CARS CORPORATION



Courtesy of VOLVO CARS CORPORATION

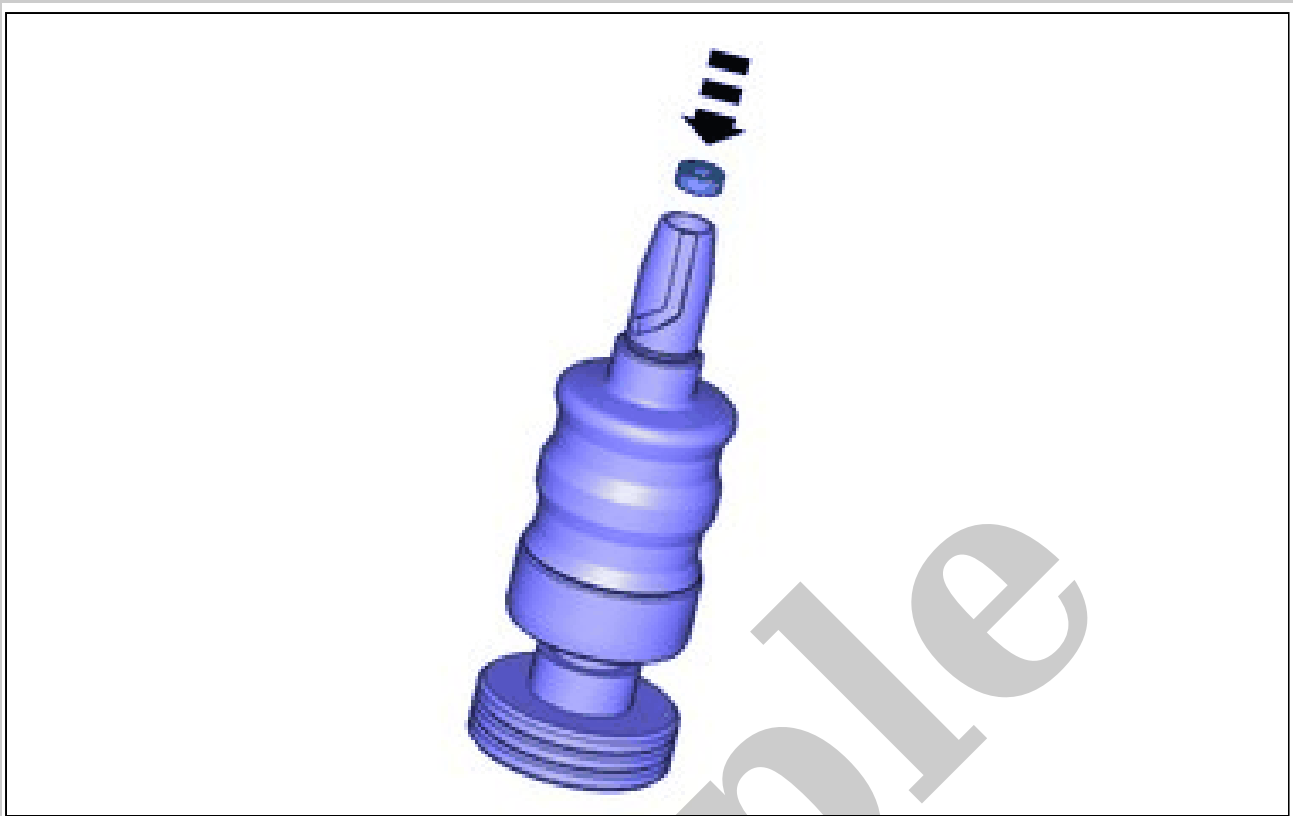

Courtesy of VOLVO CARS CORPORATION

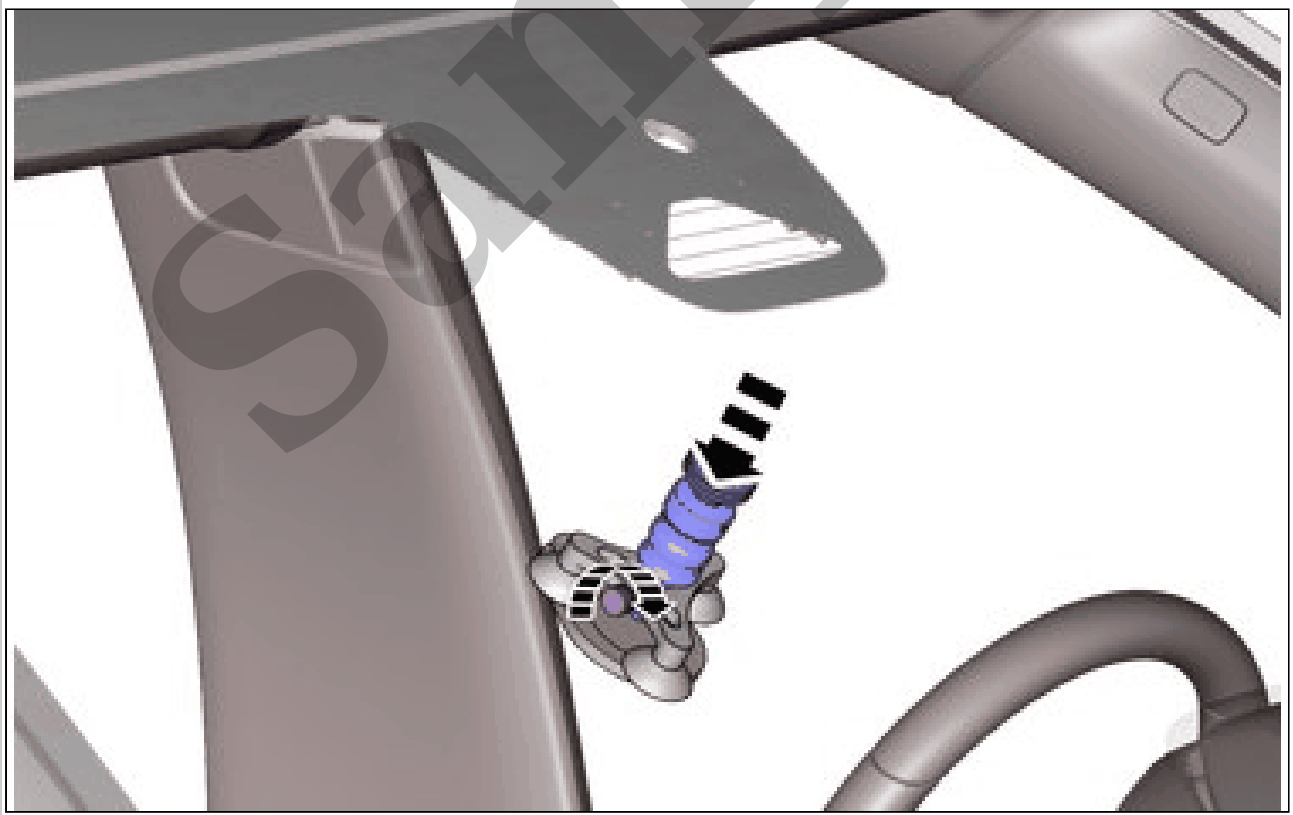

Courtesy of VOLVO CARS CORPORATION

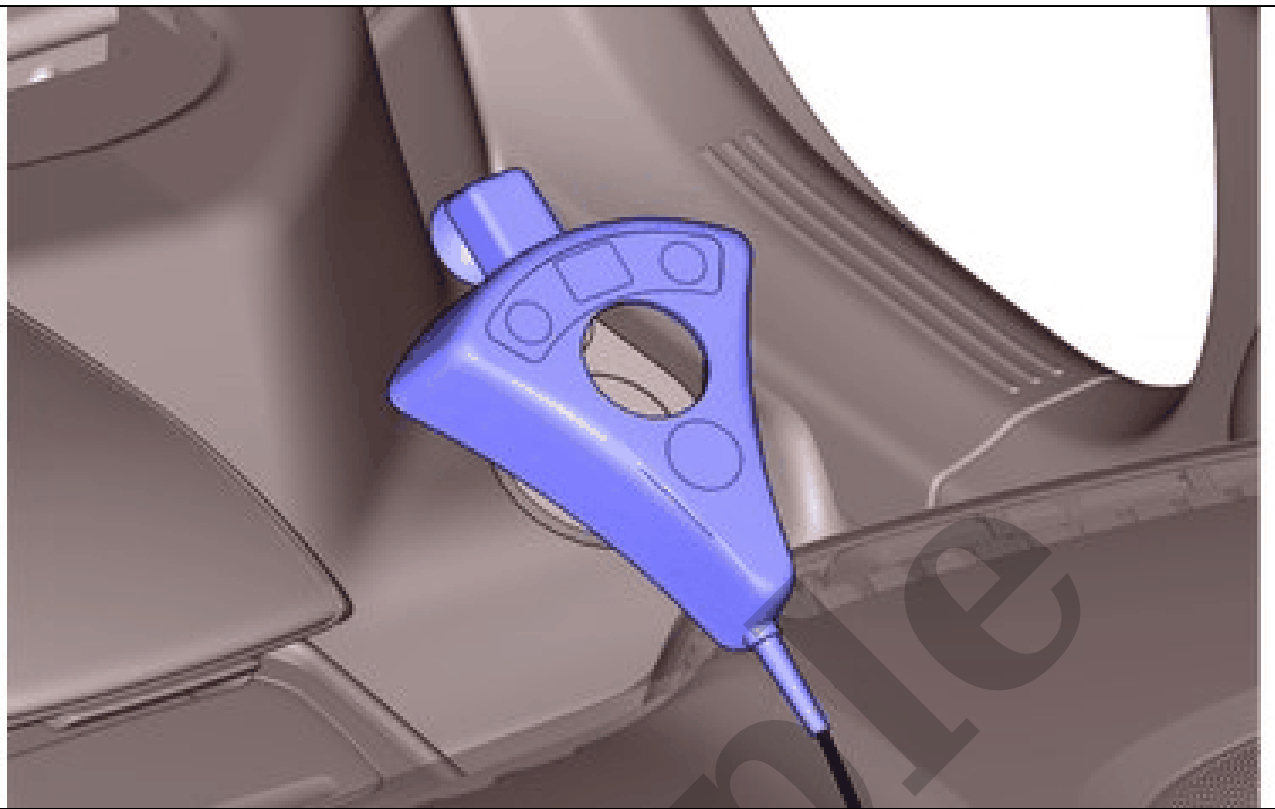

Courtesy of VOLVO CARS CORPORATION

Use UV light to cure the resin filler.

FRONT FENDER WIDENER > FRONT FENDER WIDENER [2018-2022] > REMOVAL

Remove the wheel. Refer to: WHEELS

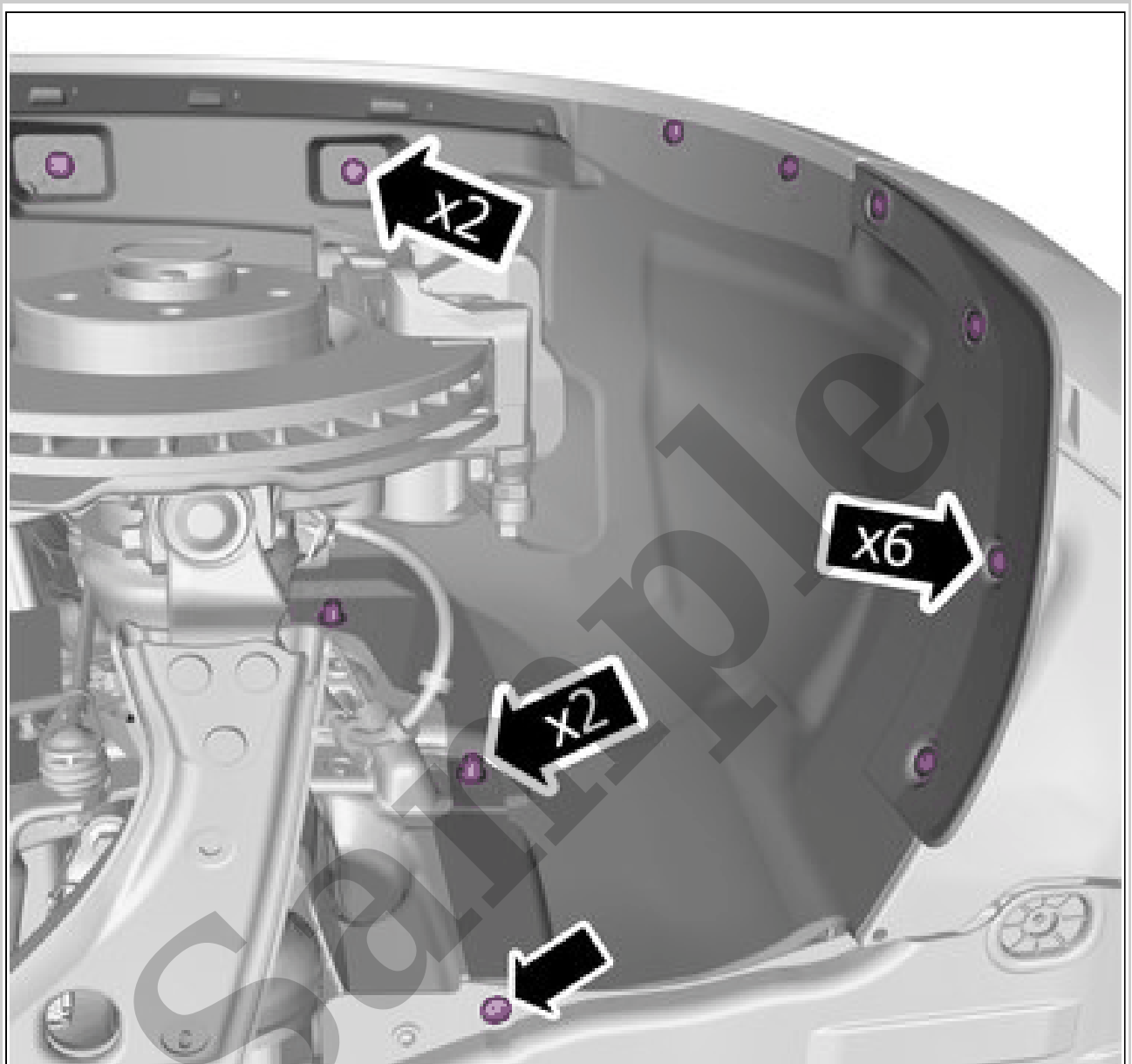

Courtesy of VOLVO CARS CORPORATION

- Remove the screws.
- Remove the nuts.
- Remove the clips.

**LOWER TRIM STRIP, FRONT DOOR > LOWER TRIM STRIP, FRONT DOOR [2018-2022]
> REMOVAL**

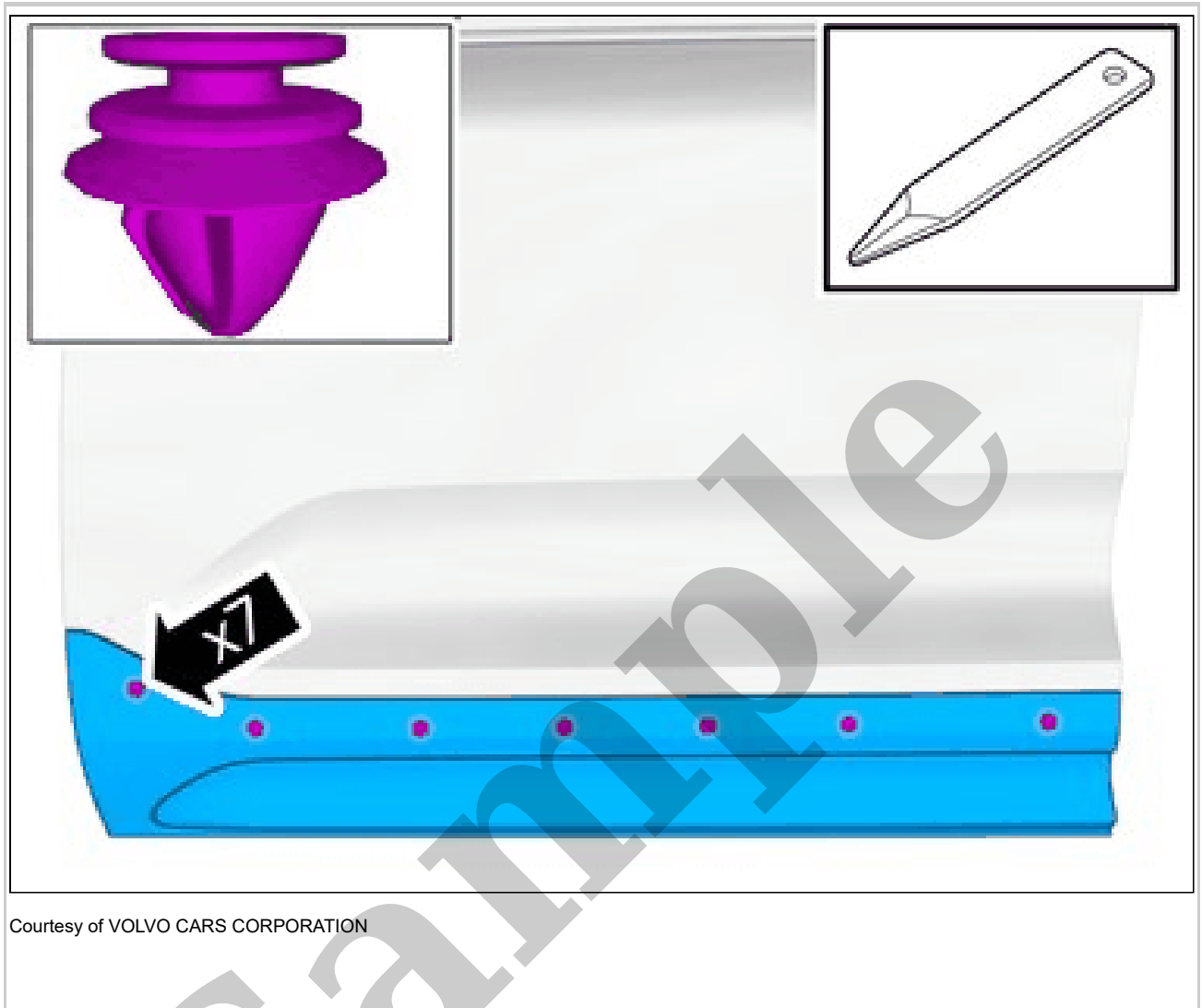

Remove the marked part.

**LOWER TRIM STRIP, FRONT DOOR > LOWER TRIM STRIP, FRONT DOOR [2018-2022]
> INSTALLATION**

To install, reverse the removal procedure.

**LOWER TRIM STRIP, REAR DOOR > LOWER TRIM STRIP, REAR DOOR [2018-2022] >
REMOVAL**

mm



Courtesy of VOLVO CARS CORPORATION



Courtesy of VOLVO CARS CORPORATION

Lift the marked component up

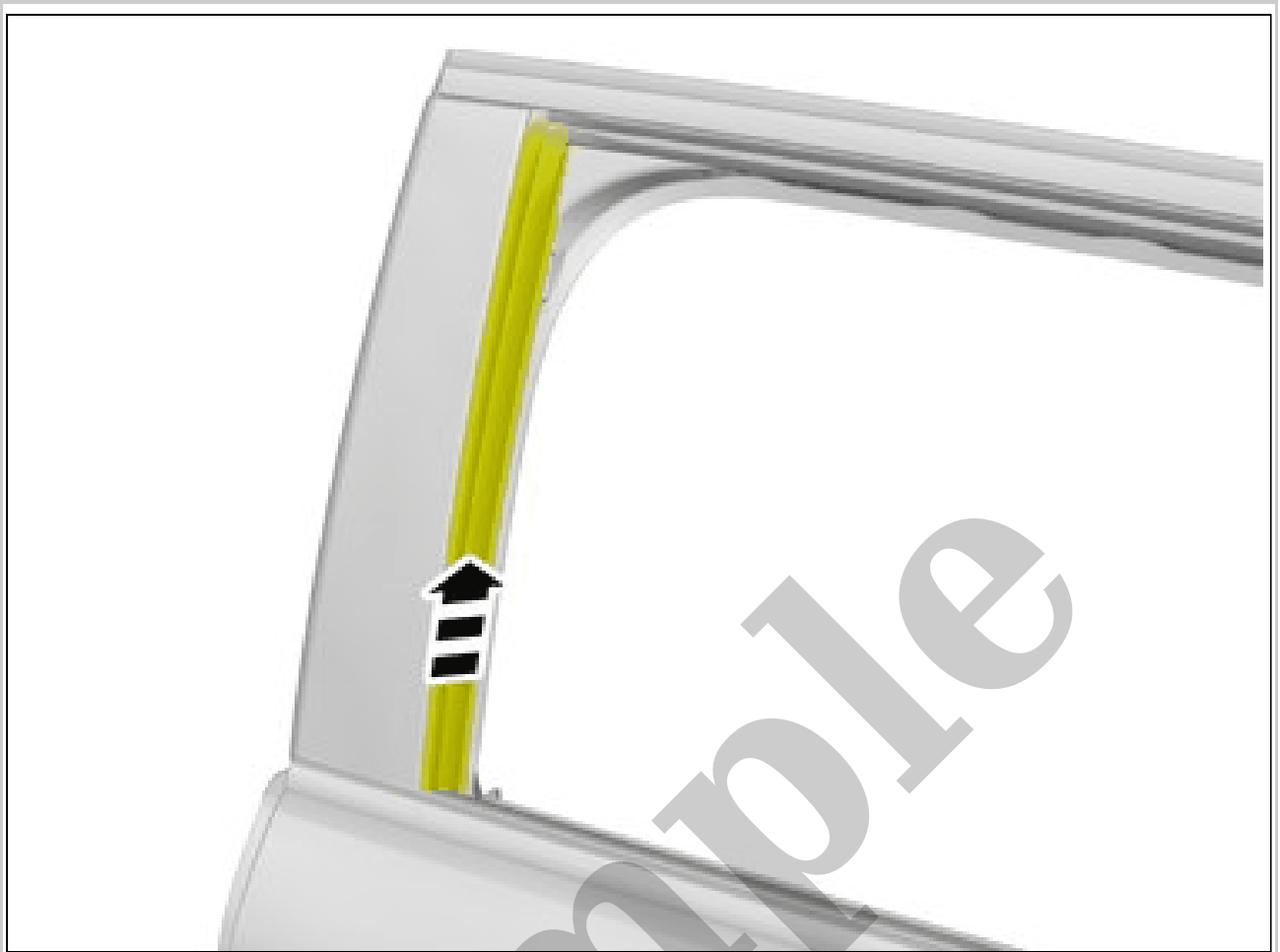

Courtesy of VOLVO CARS CORPORATION

Fold marked part aside.

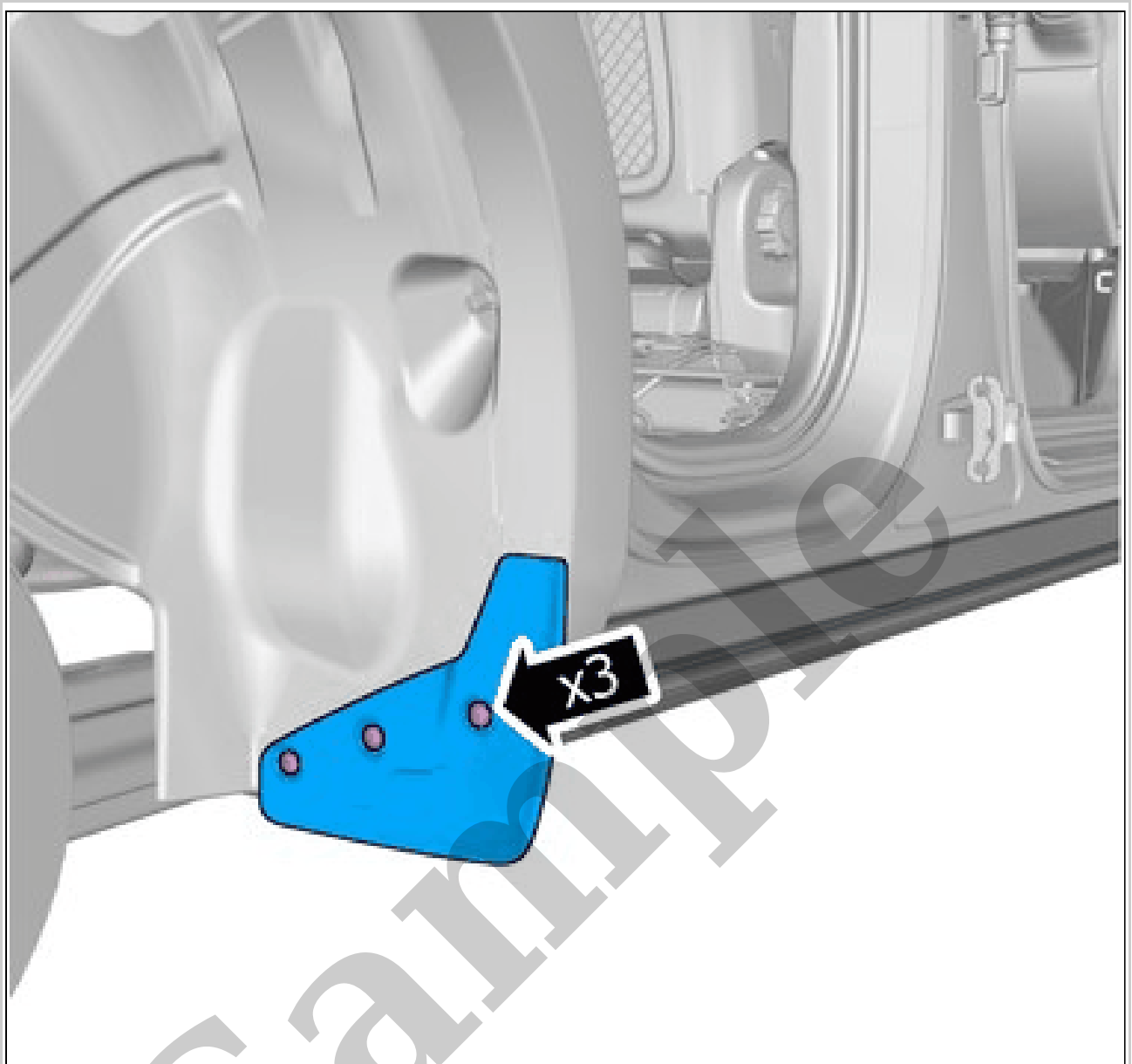

Courtesy of VOLVO CARS CORPORATION

Remove the screws.
Remove the marked part.