

Your Ultimate Source for OEM Repair Manuals

FactoryManuals.net is a great resource for anyone who wants to save money on repairs by doing their own work. The manuals provide detailed instructions and diagrams that make it easy to understand how to fix a vehicle.

2019 Volvo V90 Cross Country Service and Repair Manual

[Go to manual page](#)



Courtesy of VOLVO CARS CORPORATION

On both sides.

Sample

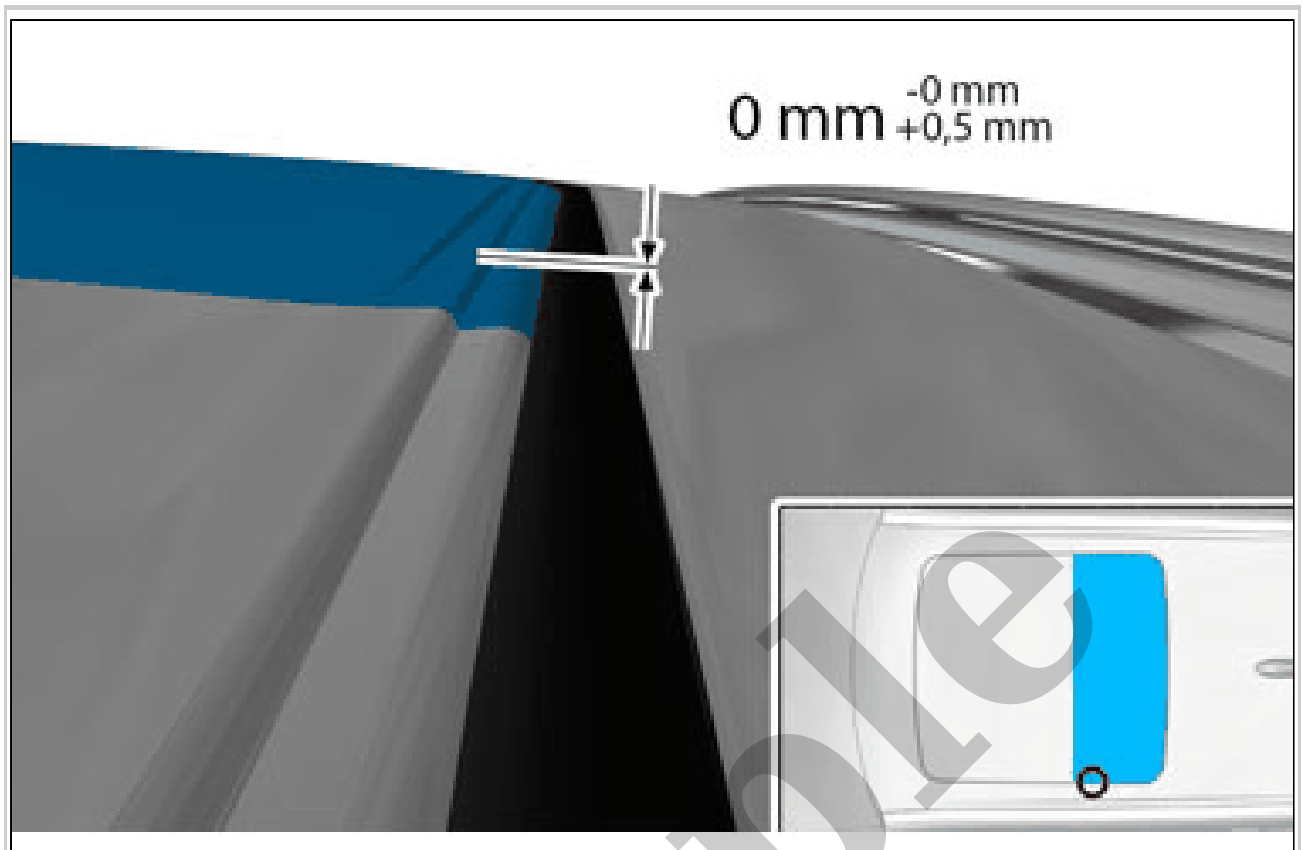

Courtesy of VOLVO CARS CORPORATION

Sample

The panorama roof motor is directly connected to the overhead console.

POWER OPERATED TAILGATE CLOSING UNIT > POWER OPERATED TAILGATE CLOSING UNIT (6/168) [2018-2022] > DESCRIPTION

The power operated tailgate closing unit has a latch that grabs the tailgate and drags it in the last part when it is closing. To open the tailgate, the latch must first be released.

POWER OPERATED TAILGATE CLOSING UNIT > POWER OPERATED TAILGATE CLOSING UNIT (6/168) [2018-2022] > DIAGNOSTIC INFORMATION

The power operated tailgate closing unit does not have a built-in diagnostic system. The Power Operated Tailgate Module (POT) monitors the unit, sets DTCs and stores readable parameters.

POWER OPERATED TAILGATE CLOSING UNIT > POWER OPERATED TAILGATE CLOSING UNIT (6/168) [2018-2022] > CONNECTION AND COMMUNICATION

The power operated tailgate closing unit is directly connected to the Power Operated Tailgate Module (POT).

POWER OPERATED TAILGATE MODULE > POWER OPERATED TAILGATE MODULE (POT) (4/116) [2018-2022] > DESCRIPTION

The Power Operated Tailgate Module (POT) controls the operation of the tailgate.

CAUTION: *Risk of damaging the components Operate the tailgate slowly if the main battery is disconnected. The entire movement must take more than 5 seconds. There is a risk of damaging the two motor, power operated tailgate, if this instruction is not followed.*

The control module communicates with the Central Electronic Module (CEM). The Power Operated Tailgate Module (POT) reads the input of the tailgate locking motor, and controls the power closing unit and the power operated tailgate motors.

POWER OPERATED TAILGATE MODULE > POWER OPERATED TAILGATE MODULE (POT) (4/116) [2018-2022] > DIAGNOSTIC INFORMATION

The Power Operated Tailgate Module (POT) has a built-in diagnostic system, which continuously monitors itself, the input and the output signals.

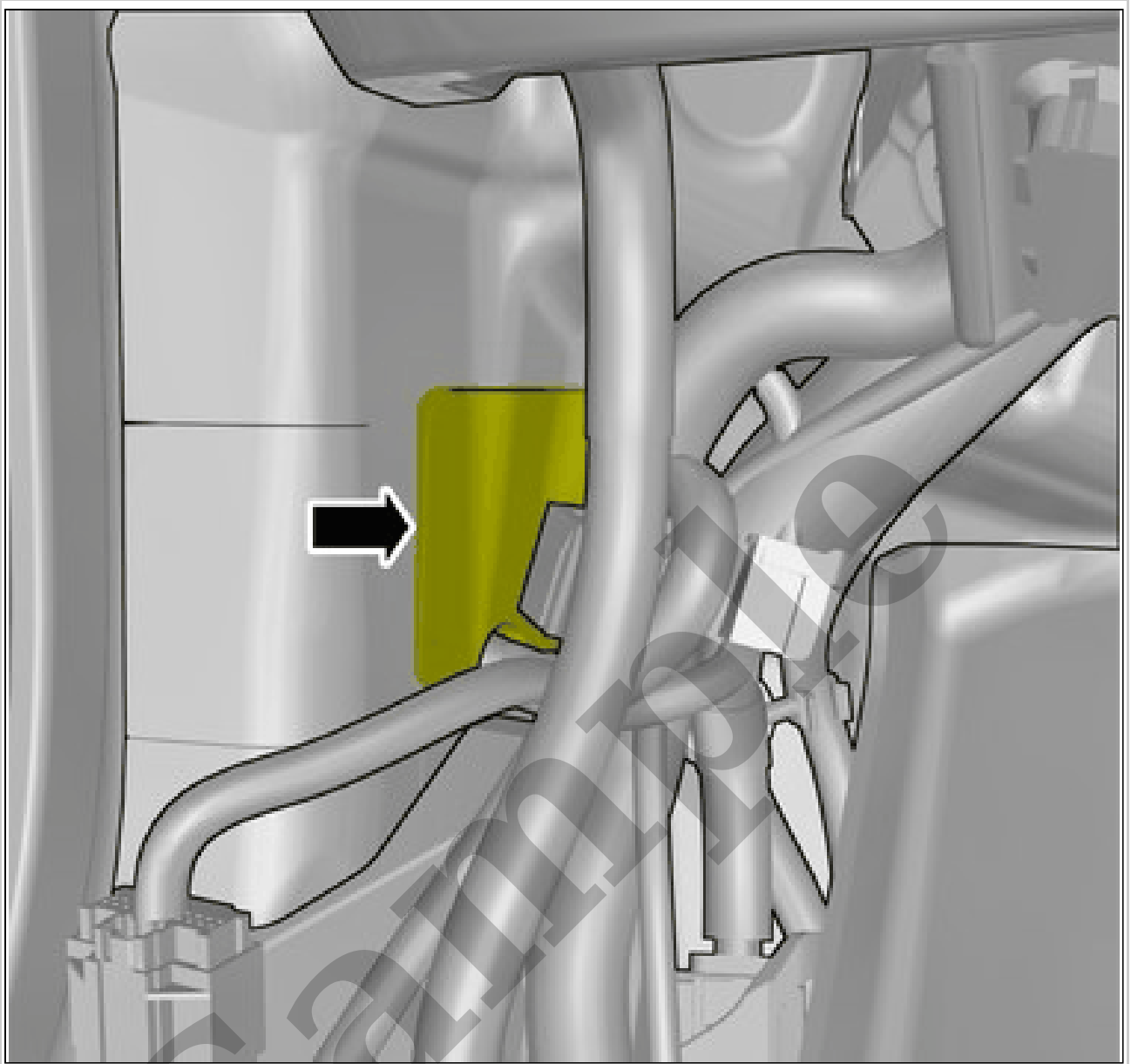

Courtesy of VOLVO CARS CORPORATION

Fold the insulation aside.

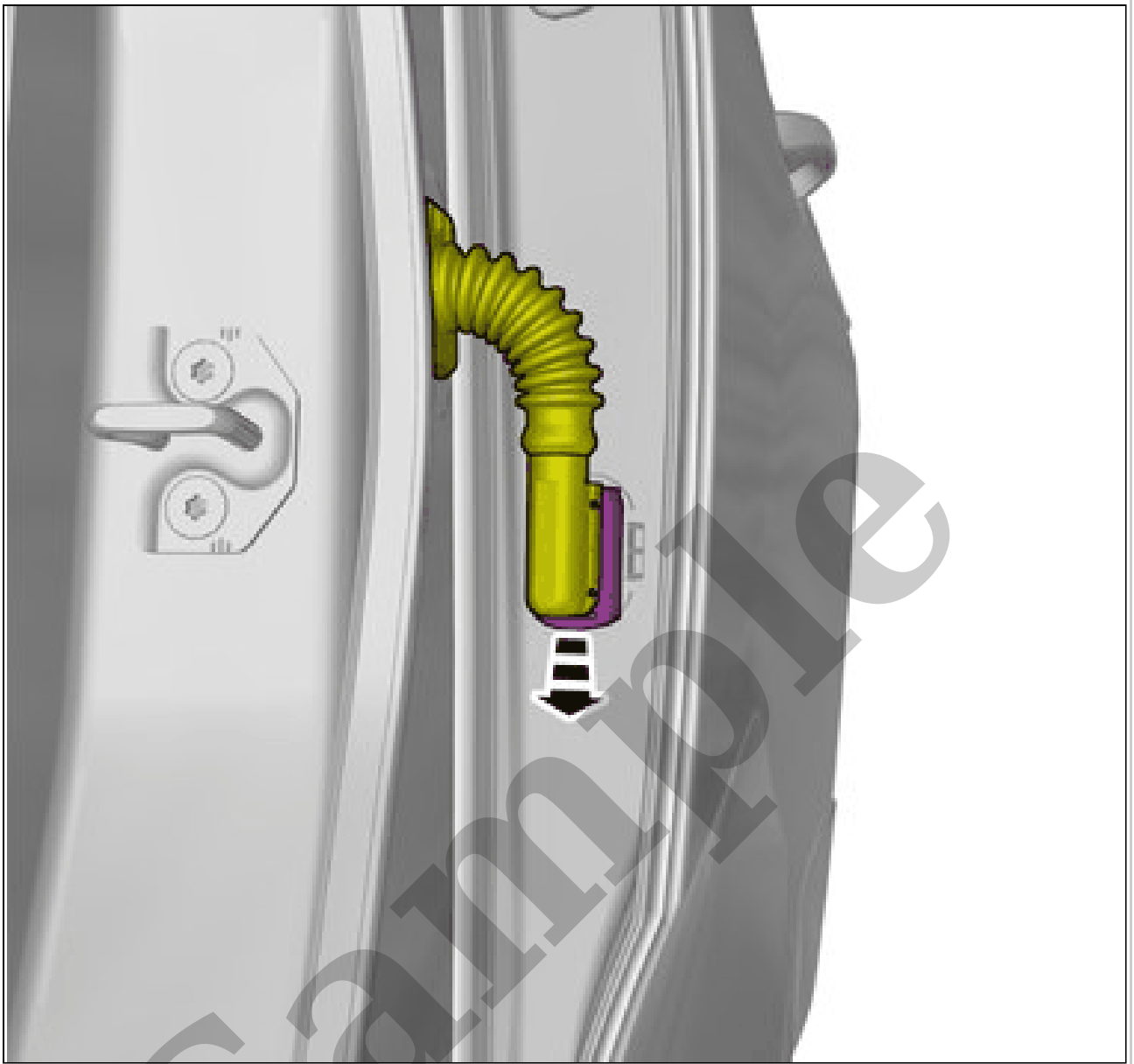

Courtesy of VOLVO CARS CORPORATION

Disconnect the connector.

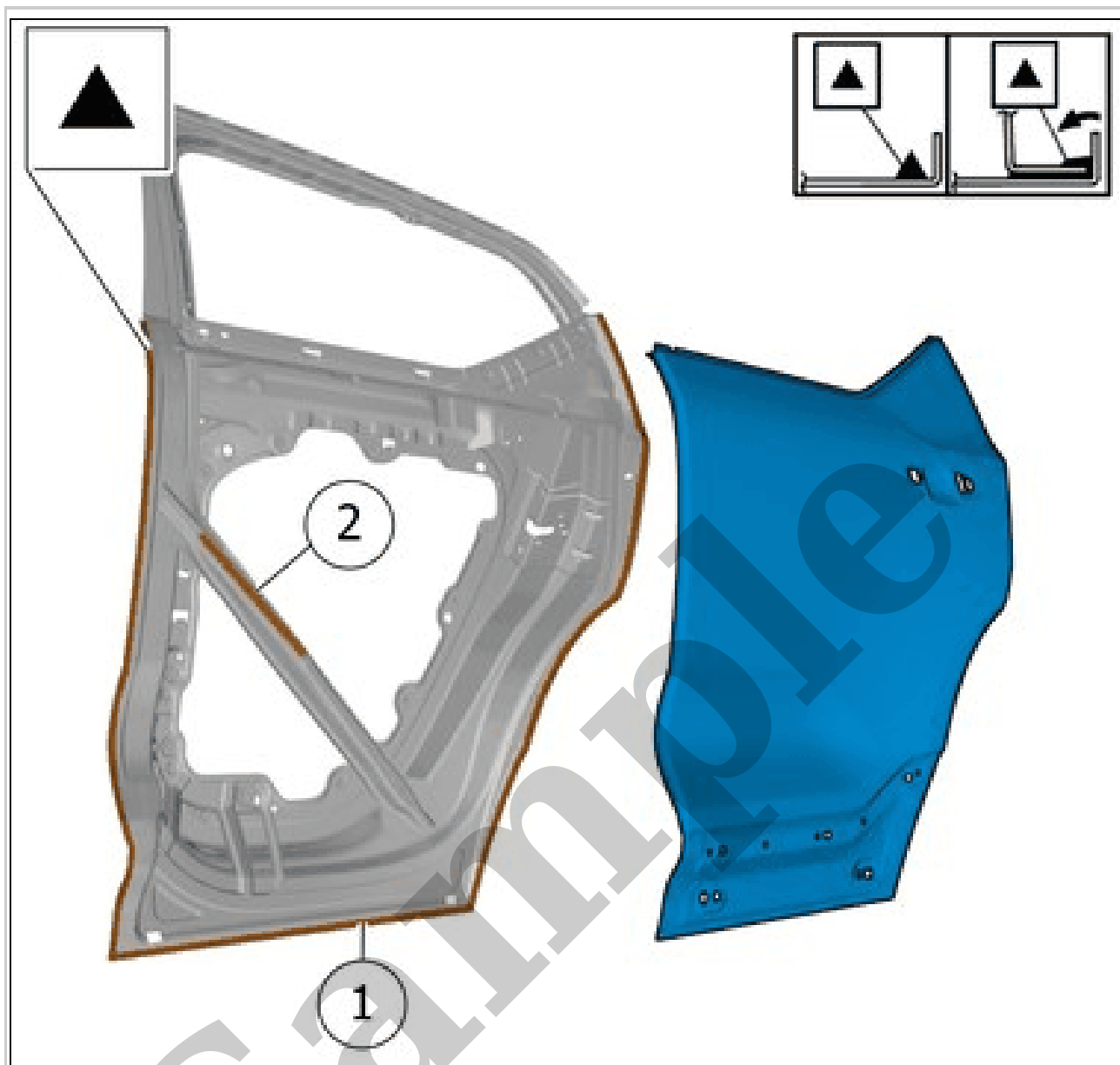

Courtesy of VOLVO CARS CORPORATION

1. **Use:** Bodywork adhesive, 30764637

2. **Use:** Sealing compound, 1161767

See information about paint. Refer to: PAINT

See information about corrosion protection. Refer to: RUSTPROOFING

DOOR PANEL > DOOR PANEL [2018-2022] > INSTALLATION

To install, reverse the removal procedure.

DOORSTOP, DOOR REAR > DOORSTOP, DOOR REAR [2018-2022] > REMOVAL

NOTE: Removal steps in this procedure may contain installation details.

Remove power window lift mechanism side door front. Refer to: LIFT MECHANISM, FRONT DOOR
Remove window side door front. Refer to: WINDOW, FRONT DOOR.
Remove trim strip lower, side door front. Refer to: LOWER TRIM STRIP, FRONT DOOR

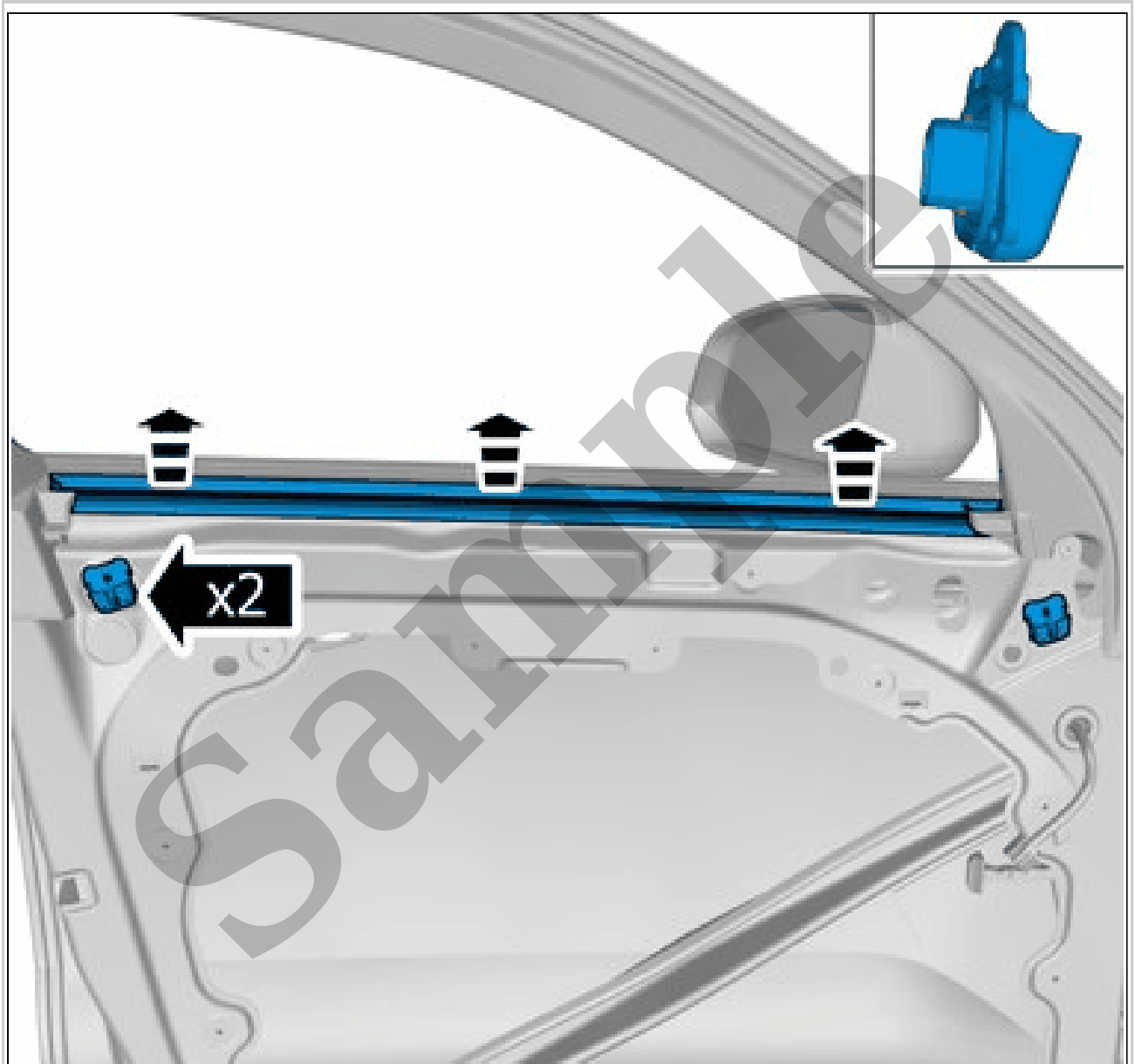

Courtesy of VOLVO CARS CORPORATION

Remove the marked part.

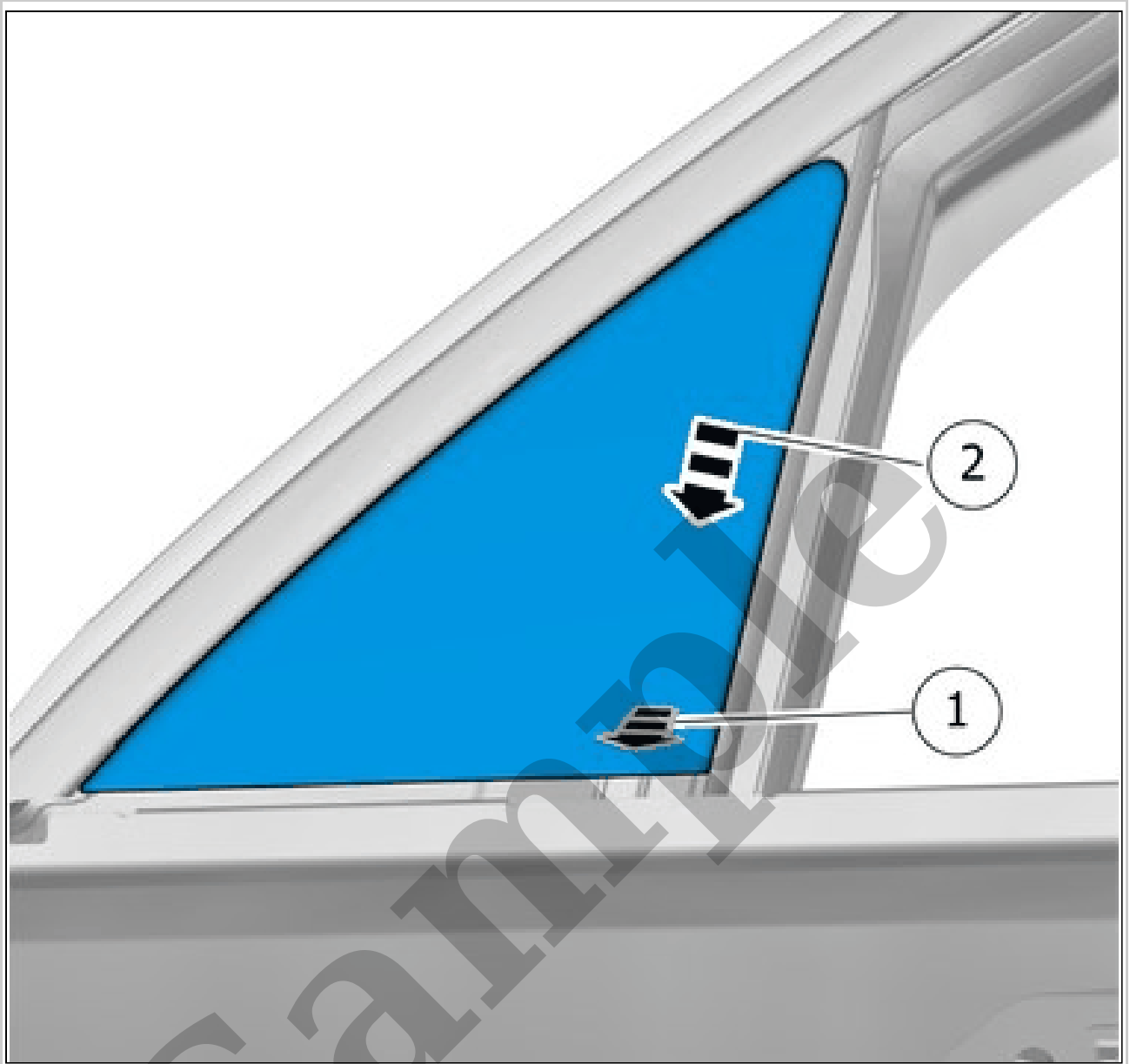

Courtesy of VOLVO CARS CORPORATION

Remove the marked part.

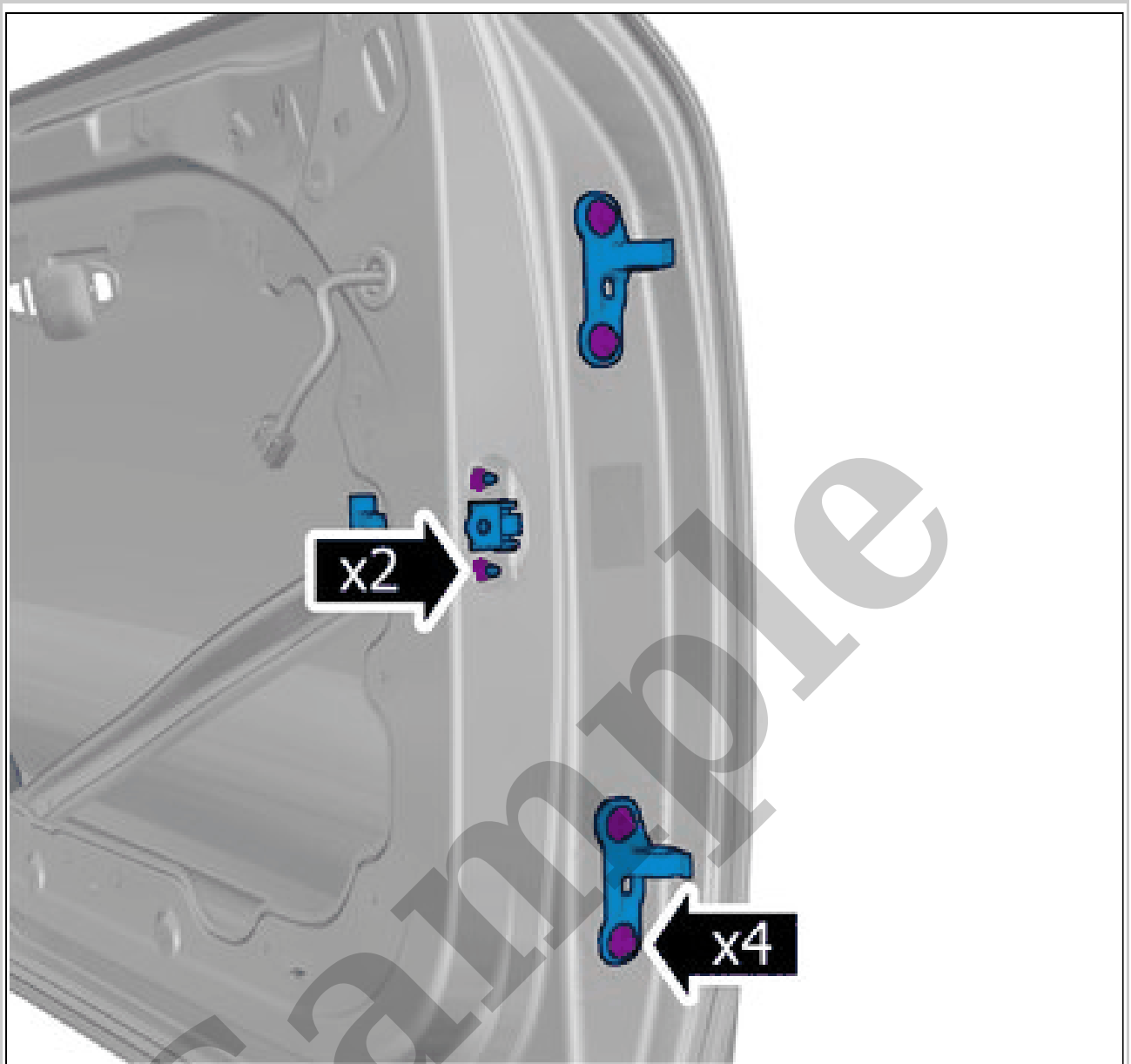

Courtesy of VOLVO CARS CORPORATION

Remove the screws.
Remove the nuts.
Remove the marked part.

1. **Torque:** M6, 10Nm
2. **Torque:** M8, 24Nm

FRONT DOOR > FRONT DOOR [2018-2022] > INSTALLATION