

# Your Ultimate Source for OEM Repair Manuals

FactoryManuals.net is a great resource for anyone who wants to save money on repairs by doing their own work. The manuals provide detailed instructions and diagrams that make it easy to understand how to fix a vehicle.

## 2018 FORD Ranger Super Cab OEM Service and Repair Workshop Manual

[Go to manual page](#)

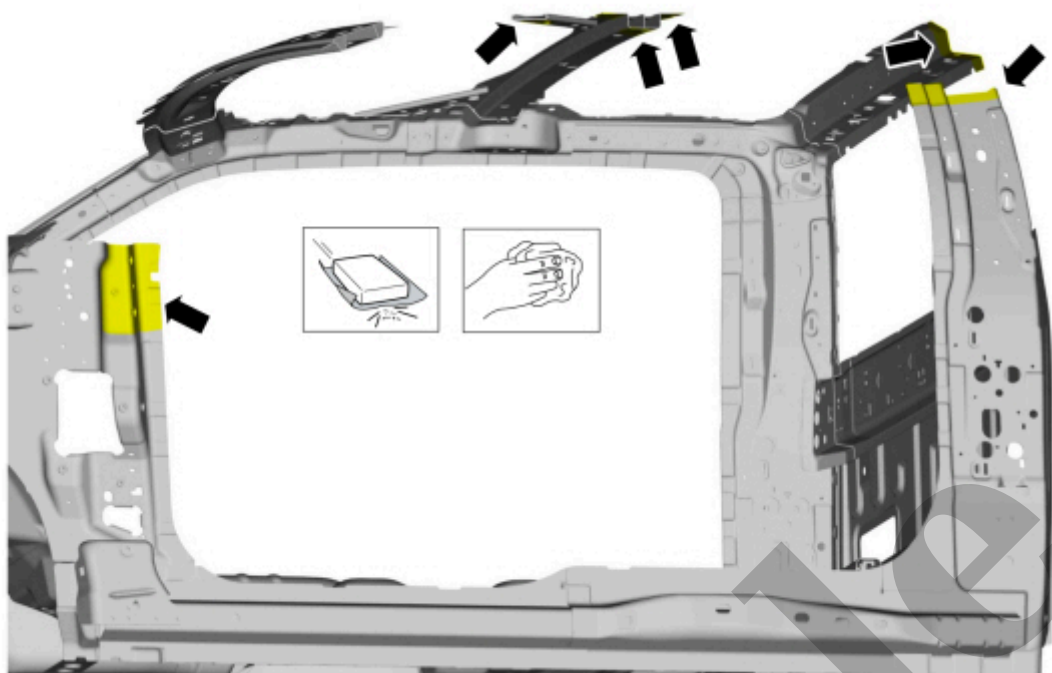

E193269

[Click here to learn about symbols, color coding, and icons used in this manual.](#)

2. Sand to remove e-coat using 80 grit sandpaper and clean.



E193270

[Click here to learn about symbols, color coding, and icons used in this manual.](#)

3. Apply adhesive.

**Material** : Metal Bonding Adhesive / TA-1, TA-1-B, 3M™ 08115, LORD Fusor® 108B, Henkel Teroson EP 5055

5. Position the windshield header panel, clamp in position and drill as indicated.

Use the General Equipment: Locking Pliers

Use the General Equipment: 6.5 mm Drill Bit

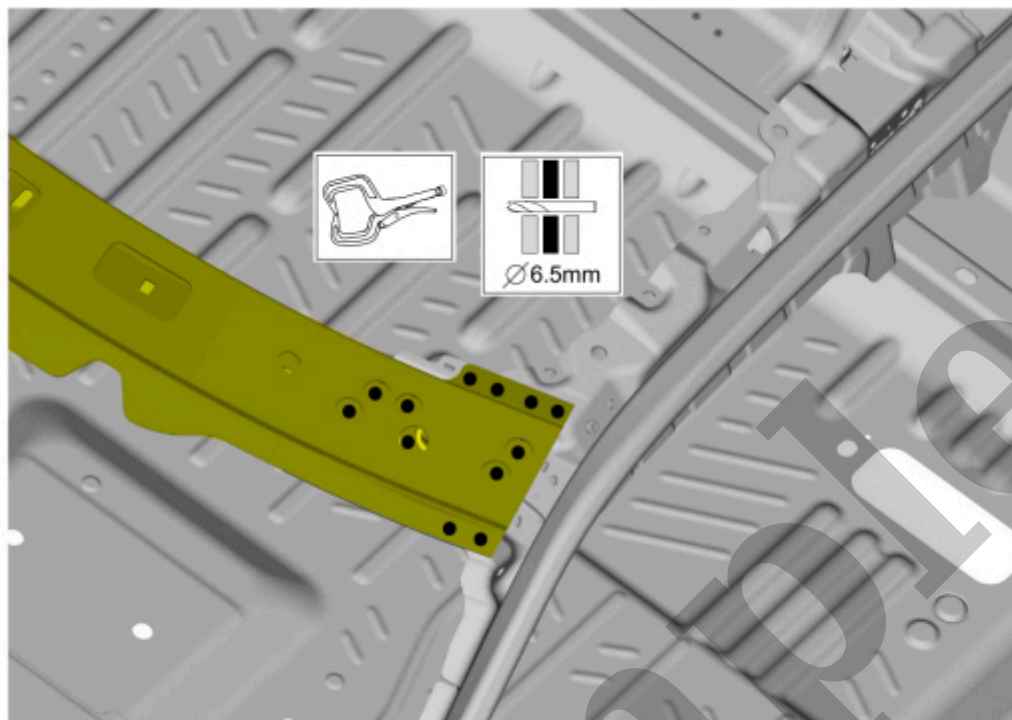

E192614

[Click here to learn about symbols, color coding, and icons used in this manual.](#)

**6. NOTE**

SPR (self-piercing rivet) fasteners may not be placed directly over original SPR (self-piercing rivet) location. They must be placed adjacent to original location matching original quantity.

**NOTE**

Solid rivets or blind rivet fasteners may be used in place of SPR (self-piercing rivet) fasteners in original SPR (self-piercing rivet) location after enlarging hole to 6.5mm.

Install the fasteners.

Item	SPR (self-piercing rivet) Number	SPR (self-piercing rivet) Code	Henrob® Mandrel	Pro-Spot® Mandrel	Blind Rivet	Solid Rivet	Rivnut®
------	----------------------------------	--------------------------------	-----------------	-------------------	-------------	-------------	---------

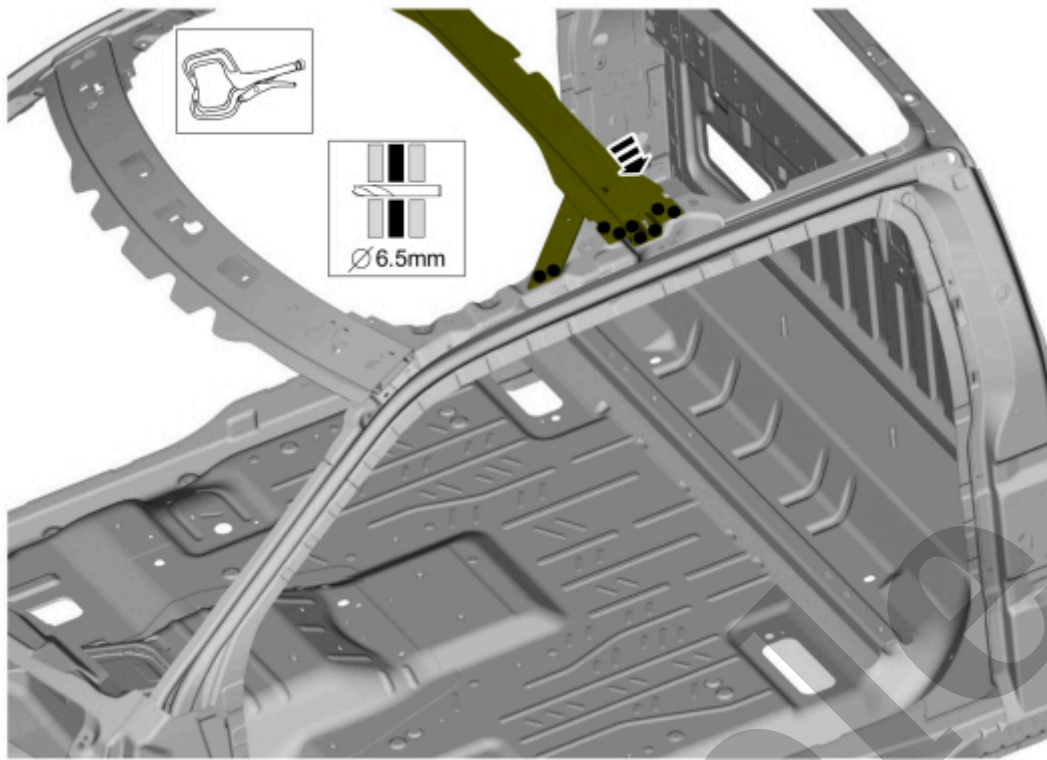

E193273

[Click here to learn about symbols, color coding, and icons used in this manual.](#)

**8. NOTE**

SPR (self-piercing rivet) fasteners may not be placed directly over original SPR (self-piercing rivet) location. They must be placed adjacent to original location matching original quantity.

**NOTE**

Solid rivets or blind rivet fasteners may be used in place of SPR (self-piercing rivet) fasteners in original SPR (self-piercing rivet) location after enlarging hole to 6.5mm.

Install the fasteners.

Item	SPR (self-piercing rivet) Number	SPR (self-piercing rivet) Code	Henrob®, Car-OLiner®, CMO®, Chief®, Spanesi®, Wielander and Schill® Mandrel	Pro-Spot® Mandrel	Blind Rivet	Solid Rivet	Rivnut®
1	-	-	-	-	W708777-S900C	-	-

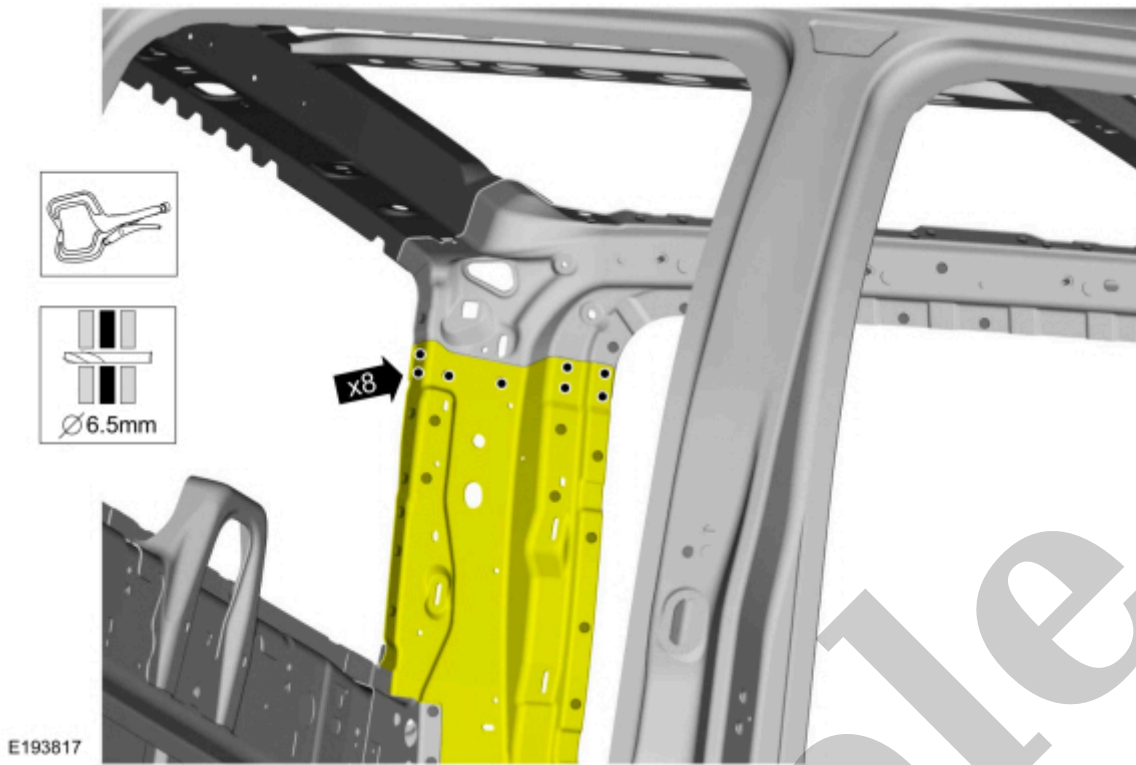

[Click here to learn about symbols, color coding, and icons used in this manual.](#)

**10. NOTE**

SPR (self-piercing rivet) fasteners may not be placed directly over original SPR (self-piercing rivet) location. They must be placed adjacent to original location matching original quantity.

**NOTE**

Solid rivets or blind rivet fasteners may be used in place of SPR (self-piercing rivet) fasteners in original SPR (self-piercing rivet) location after enlarging hole to 6.5mm.

Install the fasteners.

Item	SPR (self-piercing rivet) Number	SPR (self-piercing rivet) Code	Henrob®, Car-OLiner®, CMO®, Chief®, Spanesi®, Wielander and Schill® Mandrel	Pro-Spot® Mandrel	Blind Rivet	Solid Rivet	Rivnut®
1	-	-	-	-	W708777-S900C	W702512-S900	-

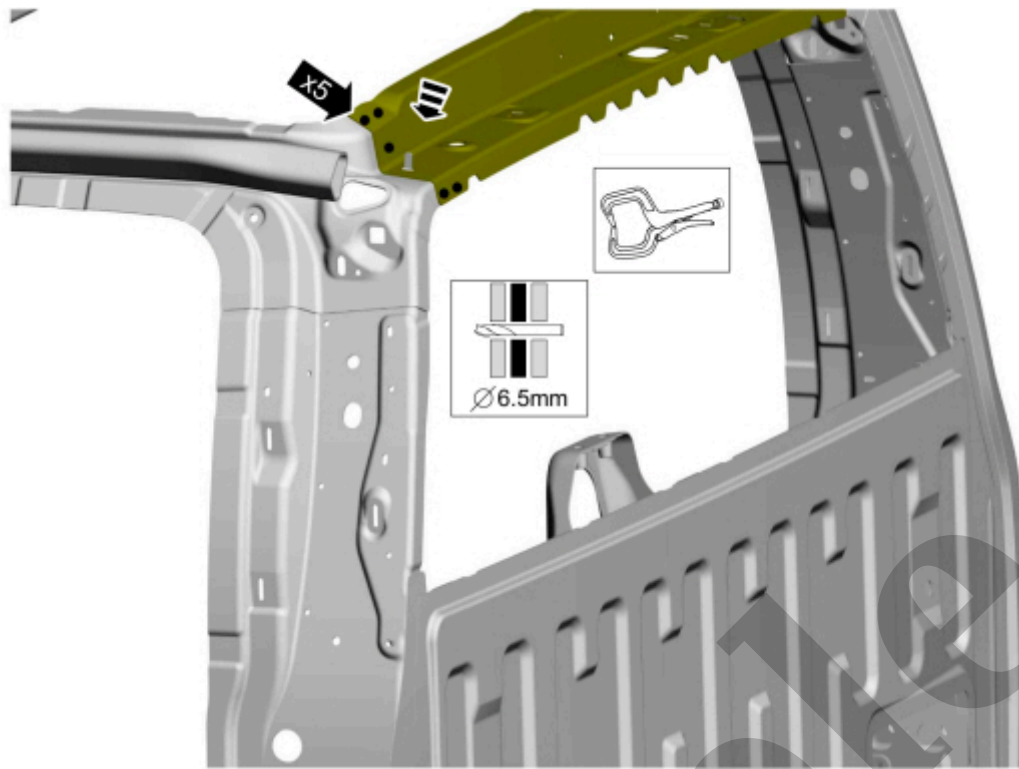

E193275

[Click here to learn about symbols, color coding, and icons used in this manual.](#)

**12. NOTE**

SPR (self-piercing rivet) fasteners may not be placed directly over original SPR (self-piercing rivet) location. They must be placed adjacent to original location matching original quantity.

**NOTE**

Solid rivets or blind rivet fasteners may be used in place of SPR (self-piercing rivet) fasteners in original SPR (self-piercing rivet) location after enlarging hole to 6.5mm.

Install the fasteners.

Item	SPR (self-piercing rivet) Number	SPR (self-piercing rivet) Code	Henrob®, Car-OLiner®, CMO®, Chief®, Spanesi®, Wielander and Schill® Mandrel	Pro-Spot® Mandrel	Blind Rivet	Solid Rivet	Rivnut®
1	-	-	-	-	W707638-S900C	-	-

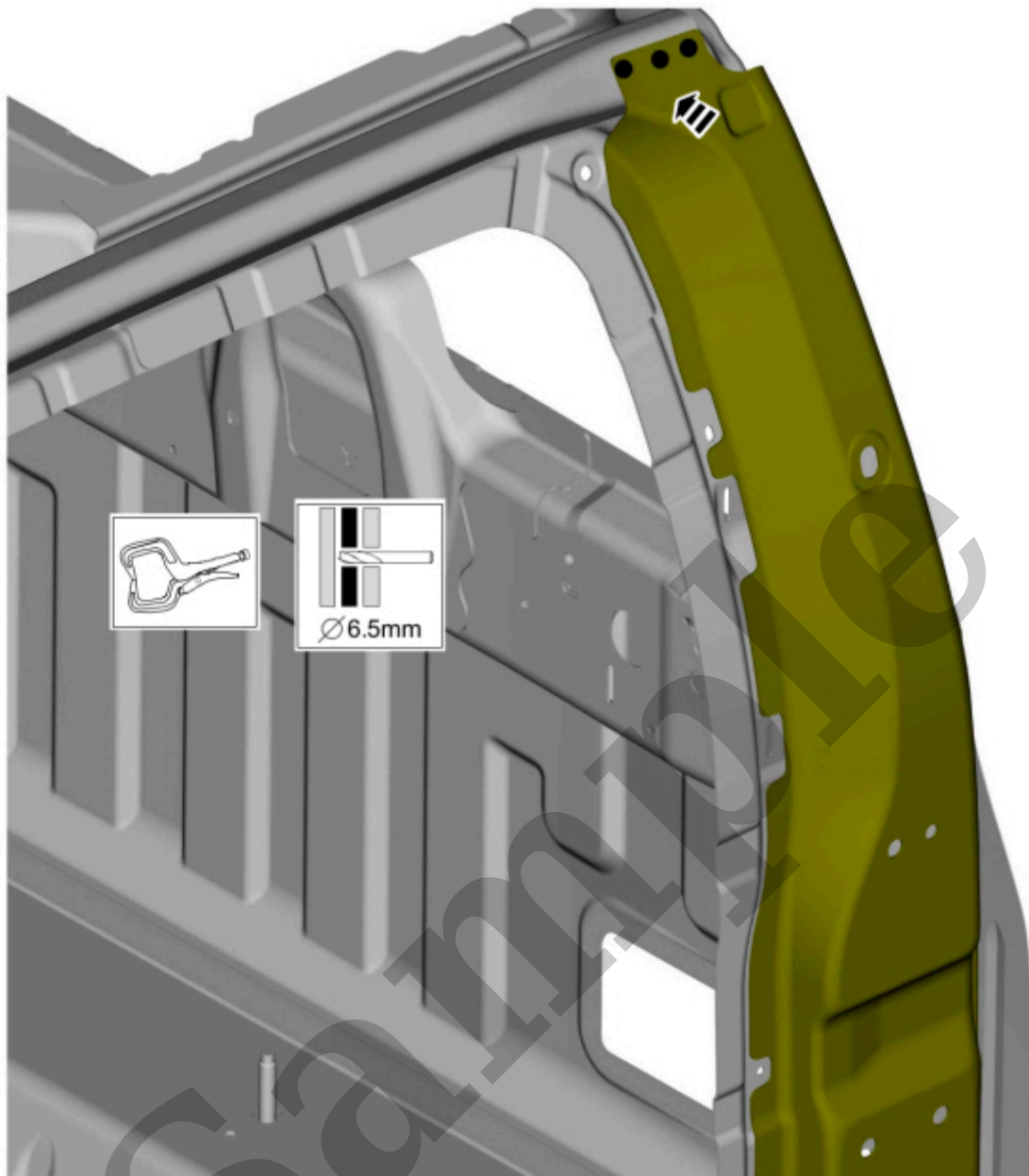

E193277

[Click here to learn about symbols, color coding, and icons used in this manual.](#)

14. **NOTE**

SPR (self-piercing rivet) fasteners may not be placed directly over original SPR (self-piercing rivet) location. They must be placed adjacent to original location matching original quantity.

**NOTE**

Solid rivets or blind rivet fasteners may be used in place of SPR (self-piercing rivet) fasteners in

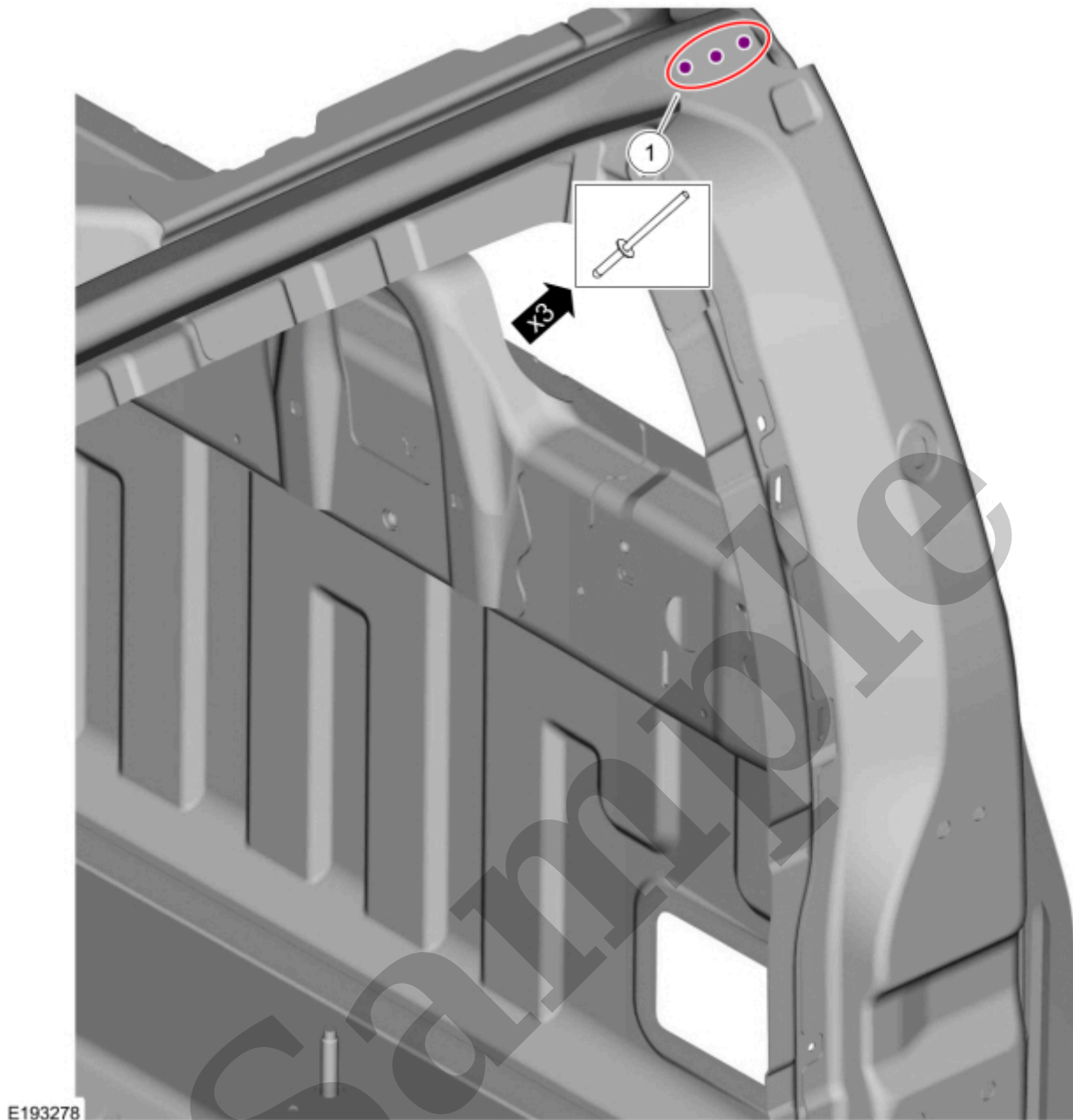

[Click here to learn about symbols, color coding, and icons used in this manual.](#)

15. Install the A-pillar reinforcement.

Refer to: [A-Pillar Outer Panel Section and Reinforcement](#)(501-29 Side Panel Sheet Metal Repairs, Removal and Installation).

16. Install the body side outer panel.

Refer to: [Body Panel Sectioning](#)(501-26 Body Repairs - Vehicle Specific Information and Tolerance Checks, General Procedures).

Refer to: [Joining Techniques](#)(501-25 Body Repairs - General Information, General Procedures).



SPR (self-piercing rivet) fasteners may not be placed directly over original SPR (self-piercing rivet) location. They must be placed adjacent to original location matching original quantity.

#### NOTE

Solid rivets or blind rivet fasteners may be used in place of SPR (self-piercing rivet) fasteners in original SPR (self-piercing rivet) location after enlarging hole to 6.5mm.

Install the fasteners.

Item	SPR (self-piercing rivet) Number	SPR (self-piercing rivet) Code	Henrob® Mandrel	Pro-Spot® Mandrel	Blind Rivet	Solid Rivet	Rivnut®
1	-	-	-	-	W702512-S900C	-	-
2	-	-	-	-	W708777-S900C	-	-

Refer to: [Joining Techniques](#)(501-25 Body Repairs - General Information, General Procedures).

Use the General Equipment: Blind Rivet Gun

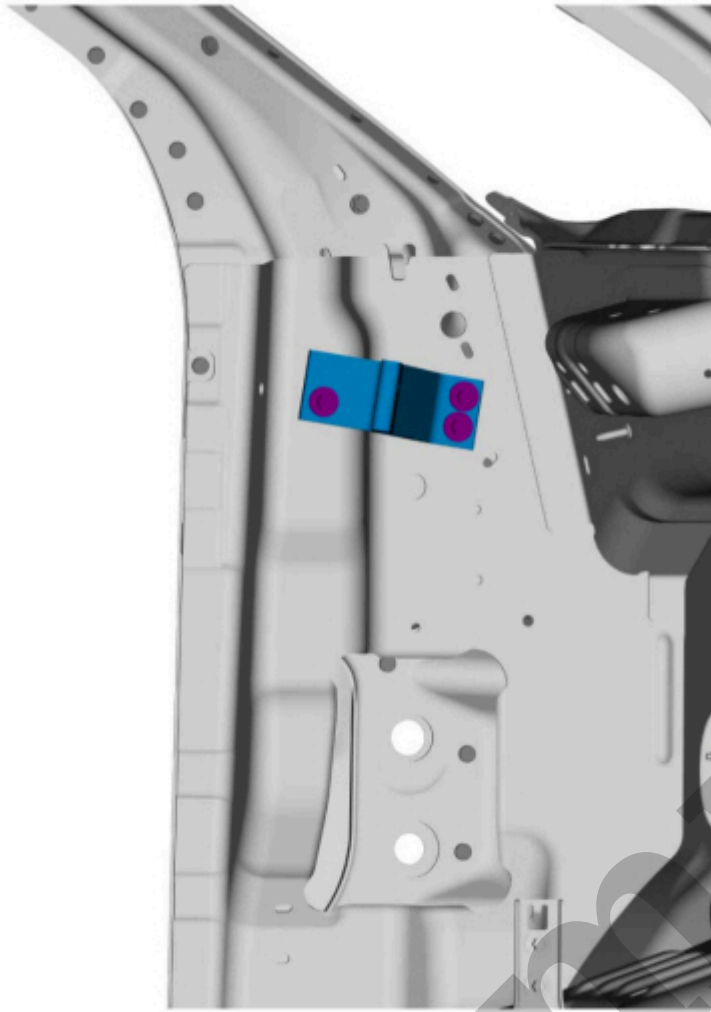

E192599

[Click here to learn about symbols, color coding, and icons used in this manual.](#)

24. Install the instrument panel.

Refer to: [Instrument Panel](#)(501-12 Instrument Panel and Console, Removal and Installation).

25. Install the front and rear doors.

Refer to: [Front Door - SuperCab](#)(501-03 Body Closures, Removal and Installation).

Refer to: [Rear Door - SuperCab](#)(501-03 Body Closures, Removal and Installation).

26. Install the fender.

Refer to: [Fender](#)(501-02 Front End Body Panels, Removal and Installation).

Refer to: [Fender Splash Shield](#)(501-02 Front End Body Panels, Removal and Installation).

27. Align the doors.

Refer to: [Front Door Alignment - SuperCab](#)(501-03 Body Closures, General Procedures).