

# Your Ultimate Source for OEM Repair Manuals

FactoryManuals.net is a great resource for anyone who wants to save money on repairs by doing their own work. The manuals provide detailed instructions and diagrams that make it easy to understand how to fix a vehicle.

## Volvo 2017 XC60 Manual - Service & Repair Guide

[Go to manual page](#)

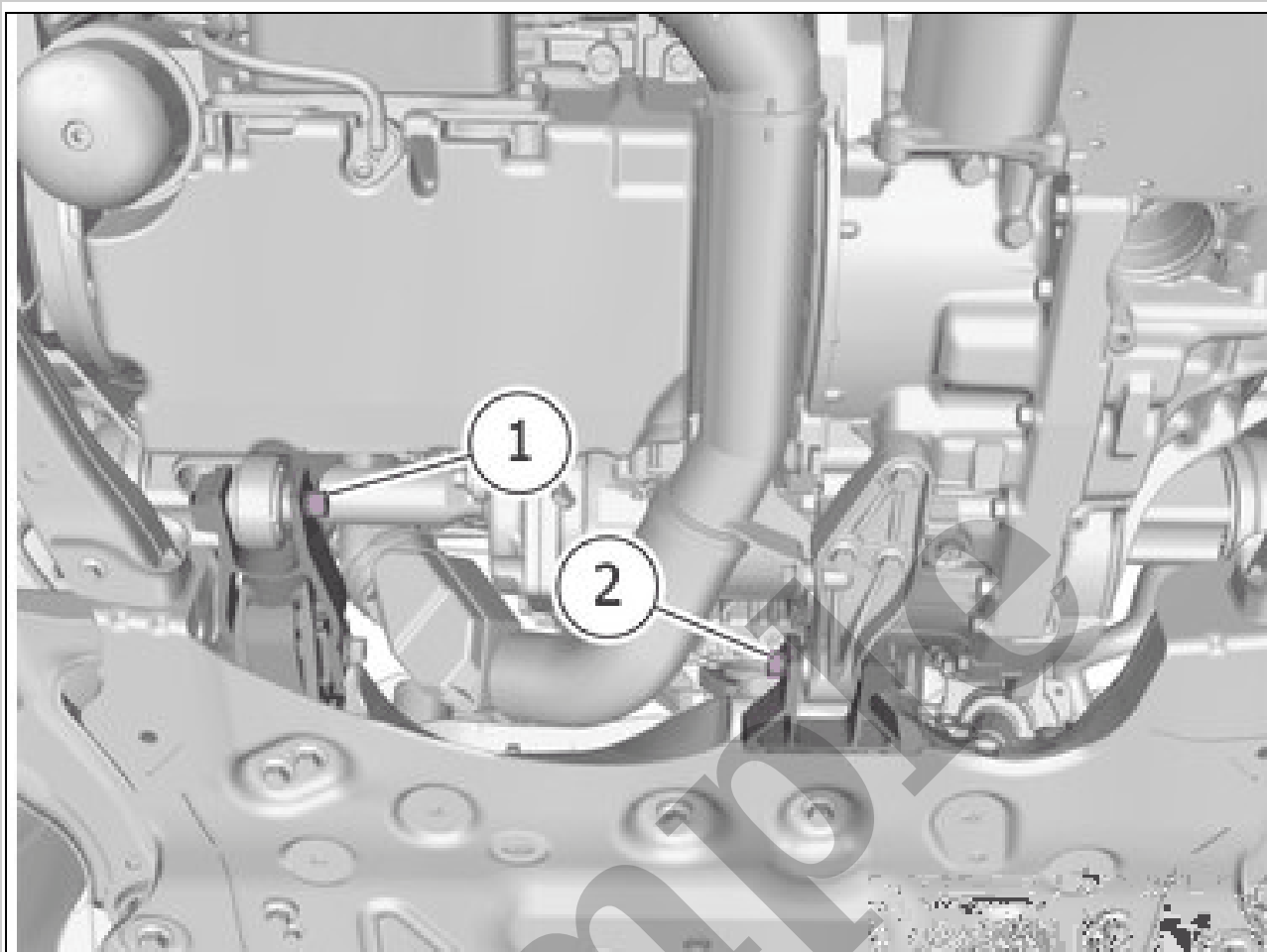

Courtesy of VOLVO CARS CORPORATION

Remove the screws.

1. **Torque:** Lower torque rod rear right, to Engine mount bracket, 110Nm
2. **Torque:** Lower torque rod rear left, to transmission bracket, 110Nm

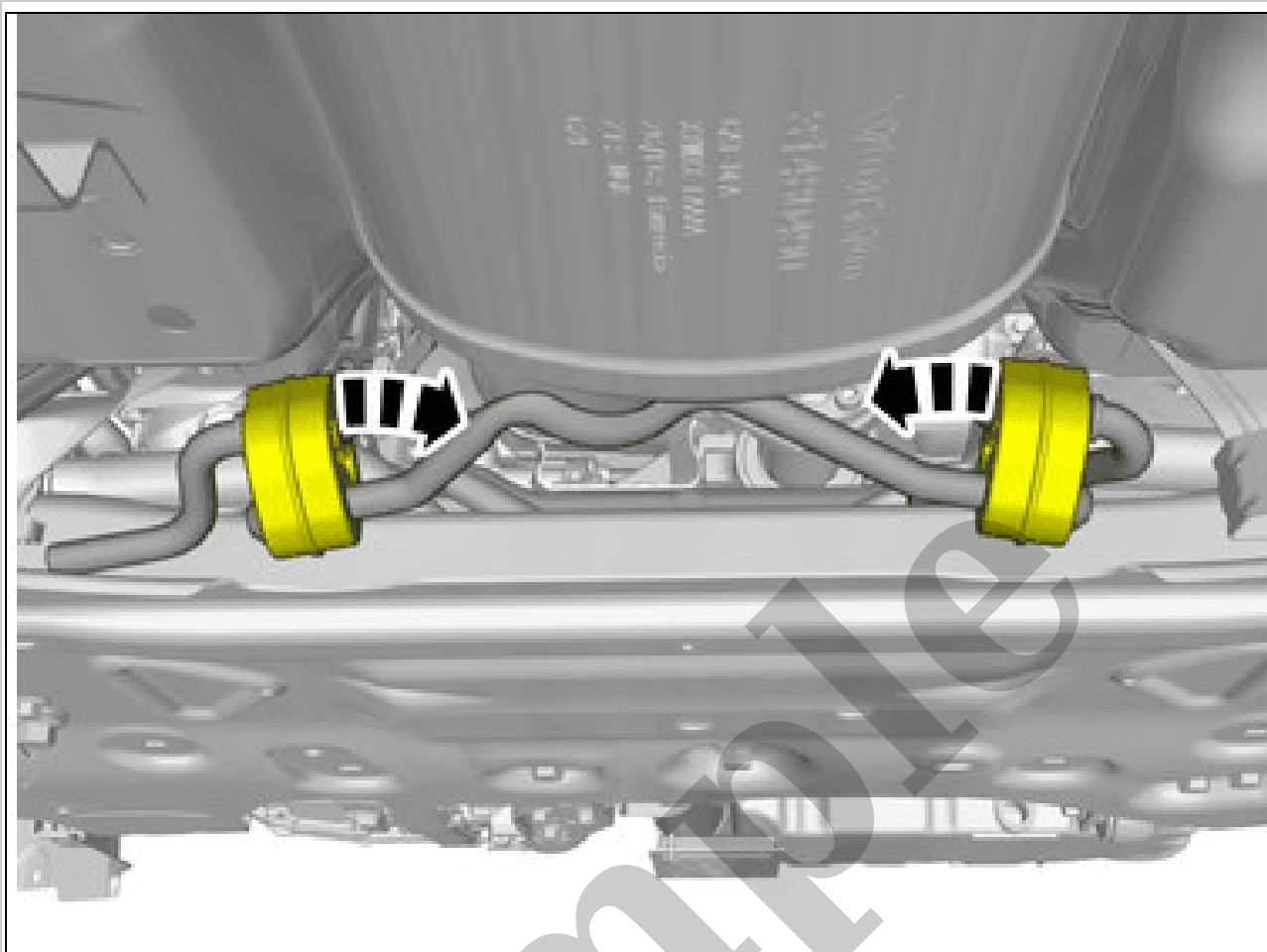

Courtesy of VOLVO CARS CORPORATION

Loosen the marked details.

**VEHICLES WITH UREA (VARIANT CODE G102)**

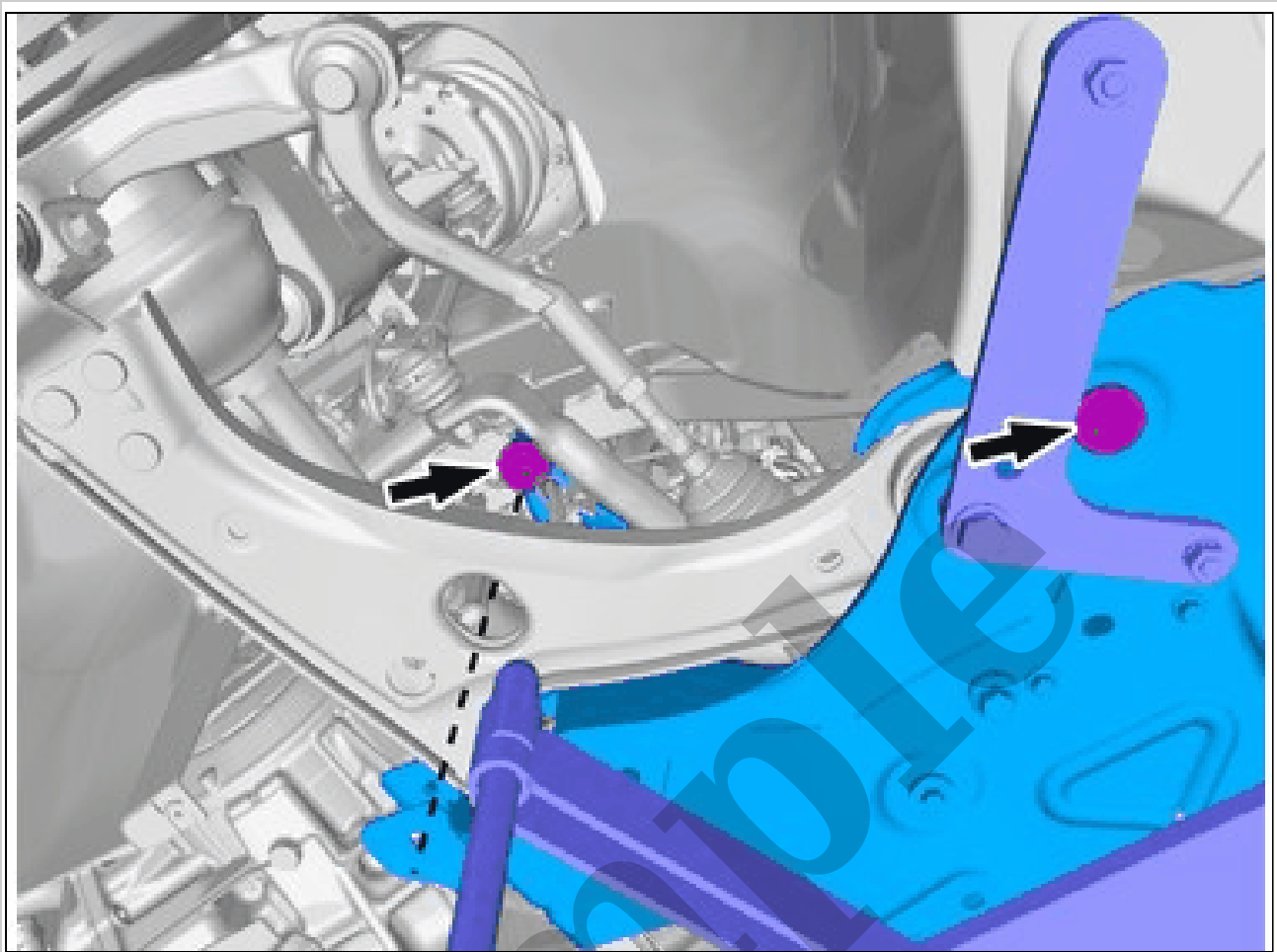

Courtesy of VOLVO CARS CORPORATION

**CAUTION:** *Make sure that new bolts are installed.*

On both sides.

Remove the screws.

**Torque:** Subframe to chassis (front screws)

- Stage 1: 90Nm
- Stage 2: 90°

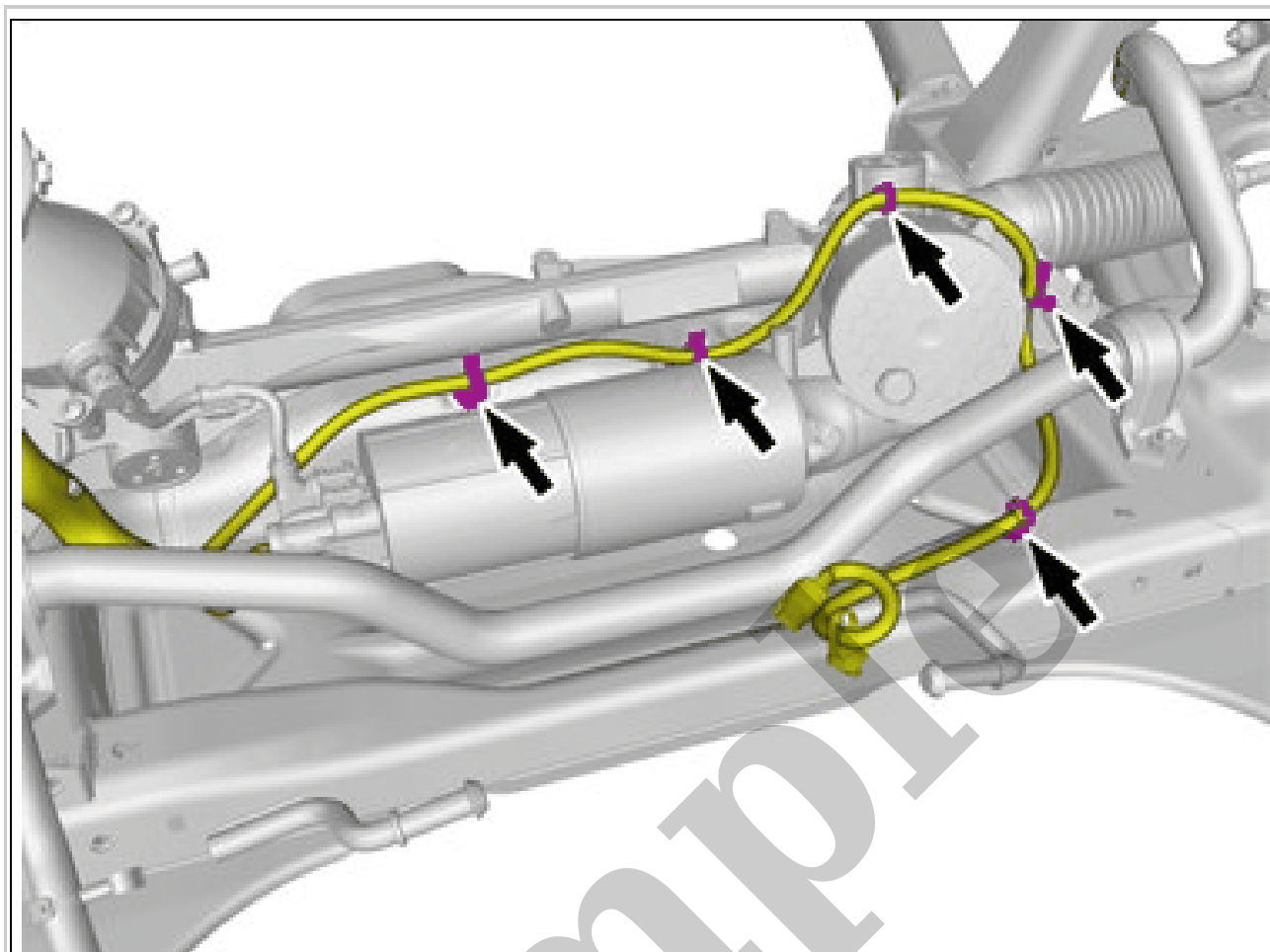

Courtesy of VOLVO CARS CORPORATION

Remove the cable harness clips.  
Loosen the wiring harness or move it to the side.  
**ALL VEHICLES**

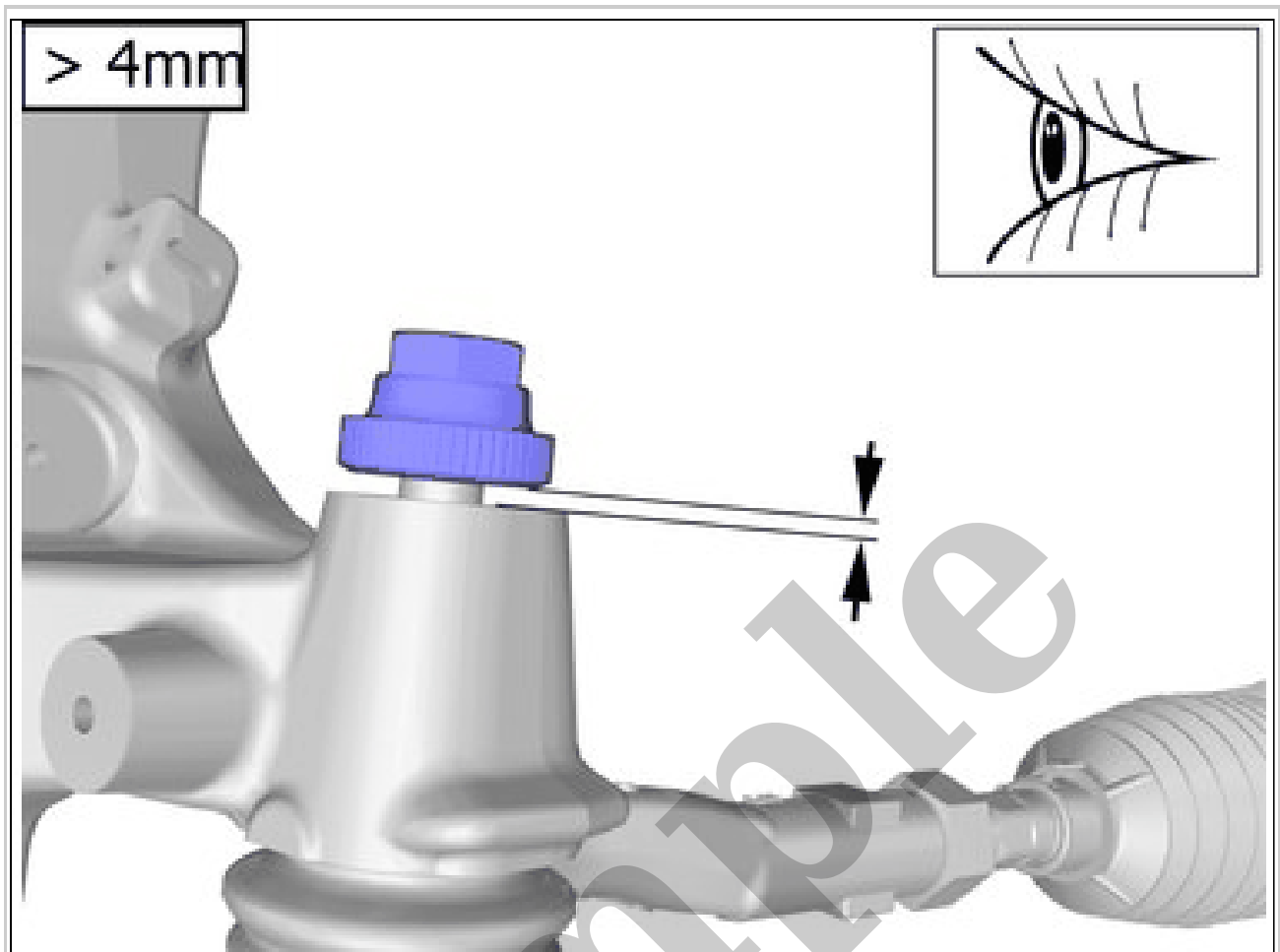

Courtesy of VOLVO CARS CORPORATION

**CAUTION:** Make sure to place the component as the graphic shows.

Special Tool: 999 7638 Pressure cap

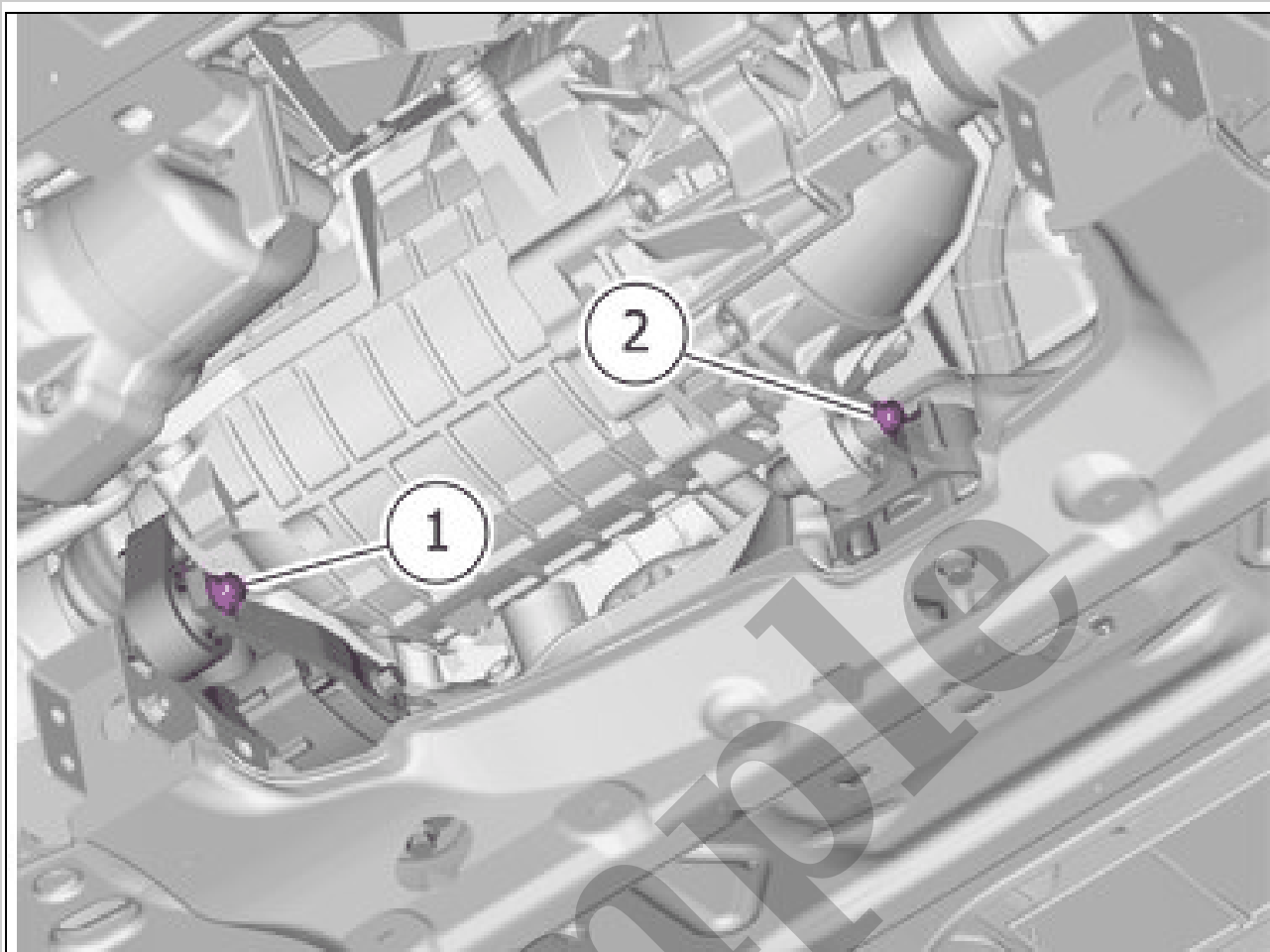

Courtesy of VOLVO CARS CORPORATION

Remove the screws.

1. **Torque:** Lower torque rod rear right, to Engine mount bracket, 110Nm
2. **Torque:** Lower torque rod rear left, to transmission, 60Nm

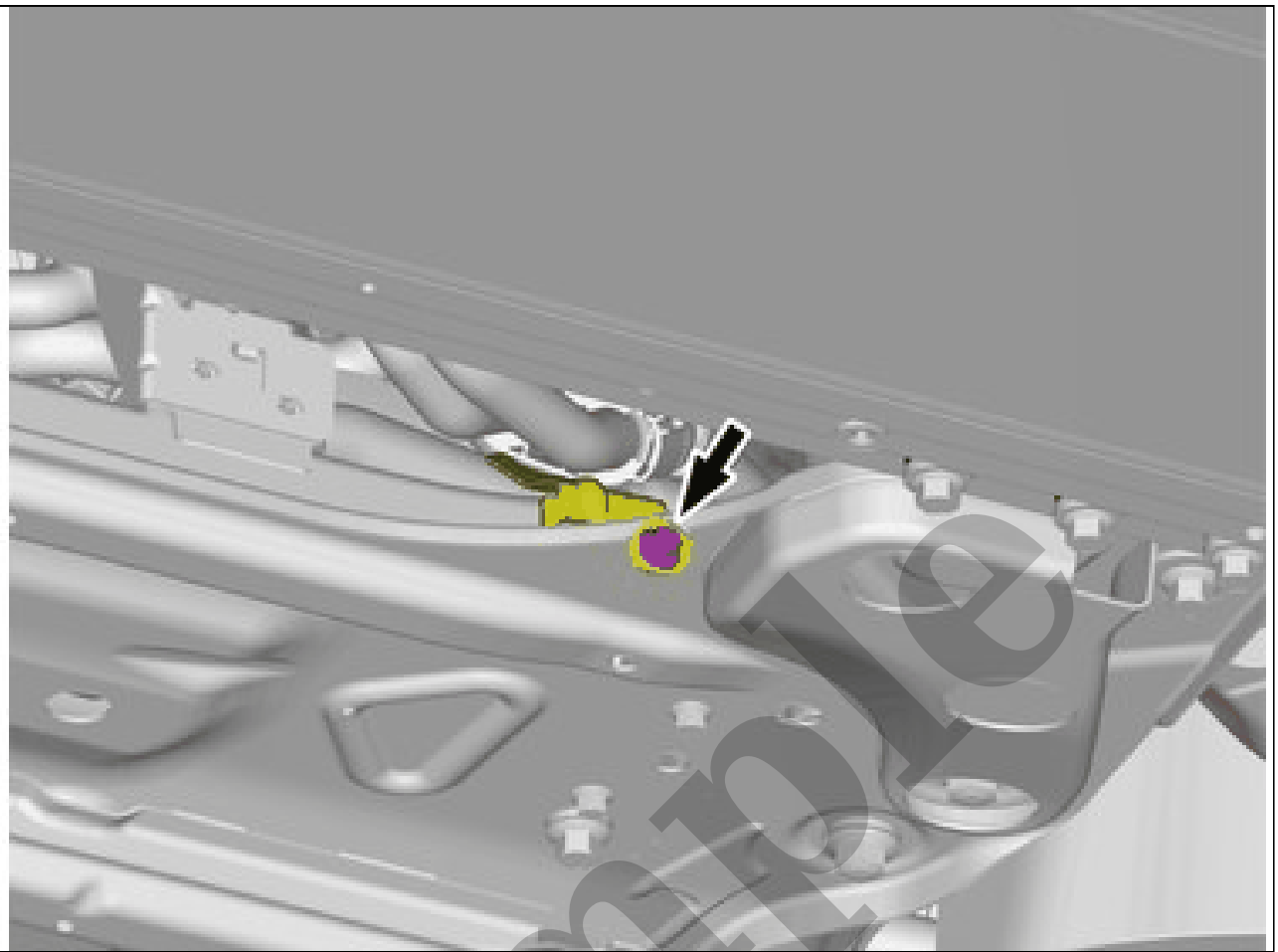

Courtesy of VOLVO CARS CORPORATION

Remove the screw.  
Fold marked part aside.  
**Torque:** M8, 24Nm



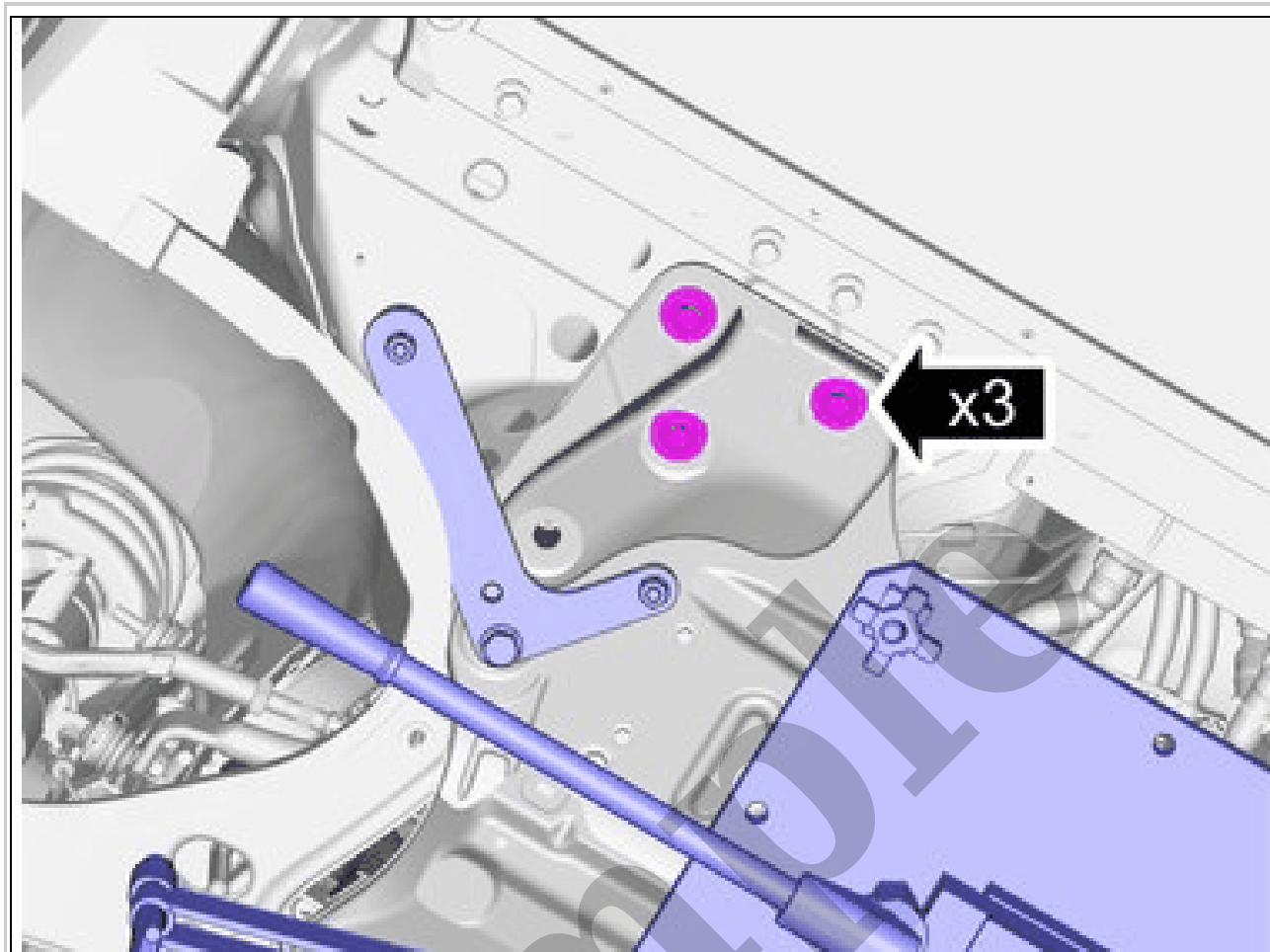

Courtesy of VOLVO CARS CORPORATION

On both sides.

Remove the screws.

**Torque:** Subframe to chassis (rear screws)

- Stage 1: 90Nm
- Stage 2: 60°

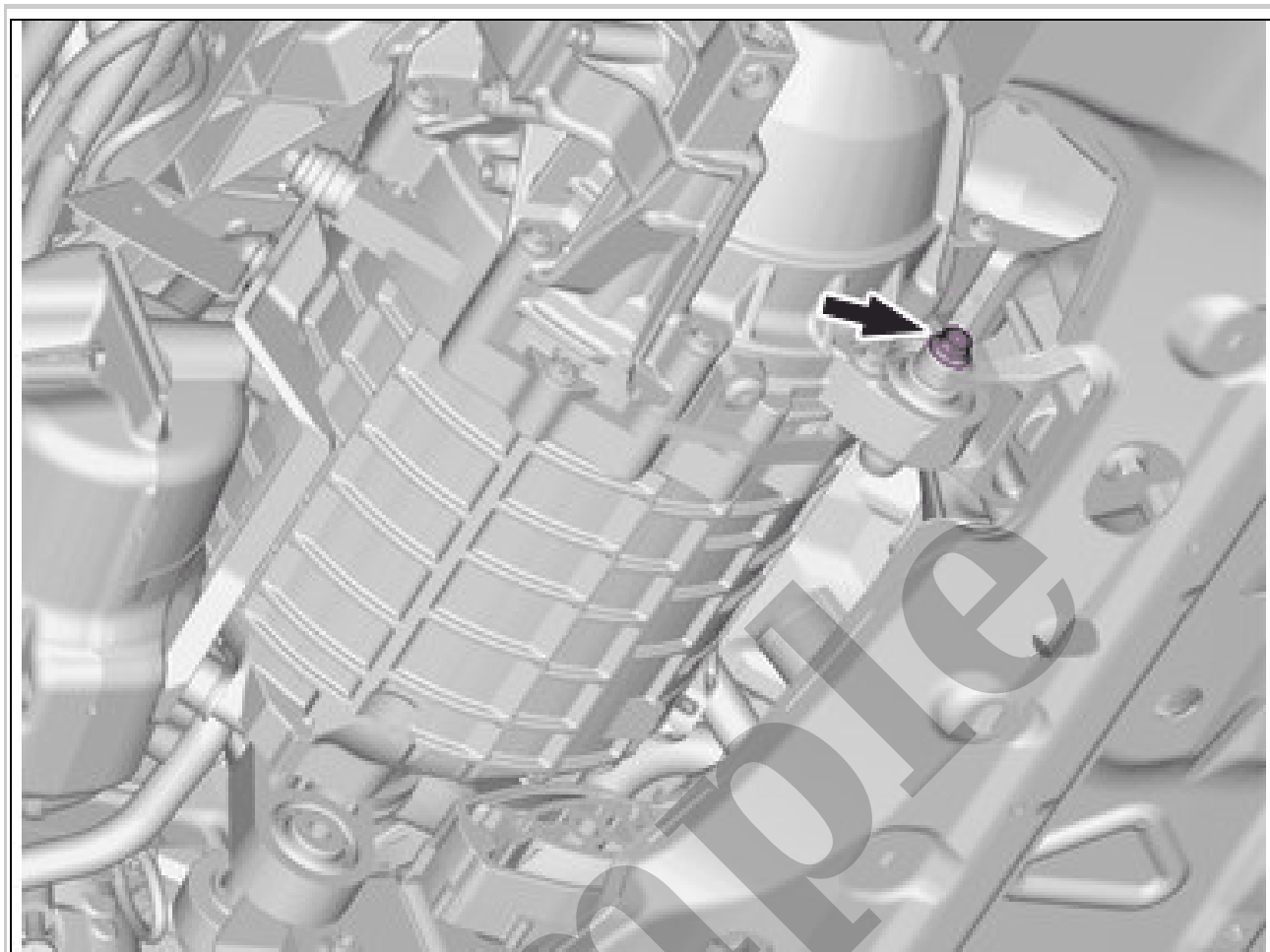

Courtesy of VOLVO CARS CORPORATION

Remove the screw.

**Torque:** Lower torque rod rear left, to transmission, 60Nm