

# Your Ultimate Source for OEM Repair Manuals

FactoryManuals.net is a great resource for anyone who wants to save money on repairs by doing their own work. The manuals provide detailed instructions and diagrams that make it easy to understand how to fix a vehicle.

## 2017 FORD Fusion Hybrid OEM Service and Repair Workshop Manual

[Go to manual page](#)

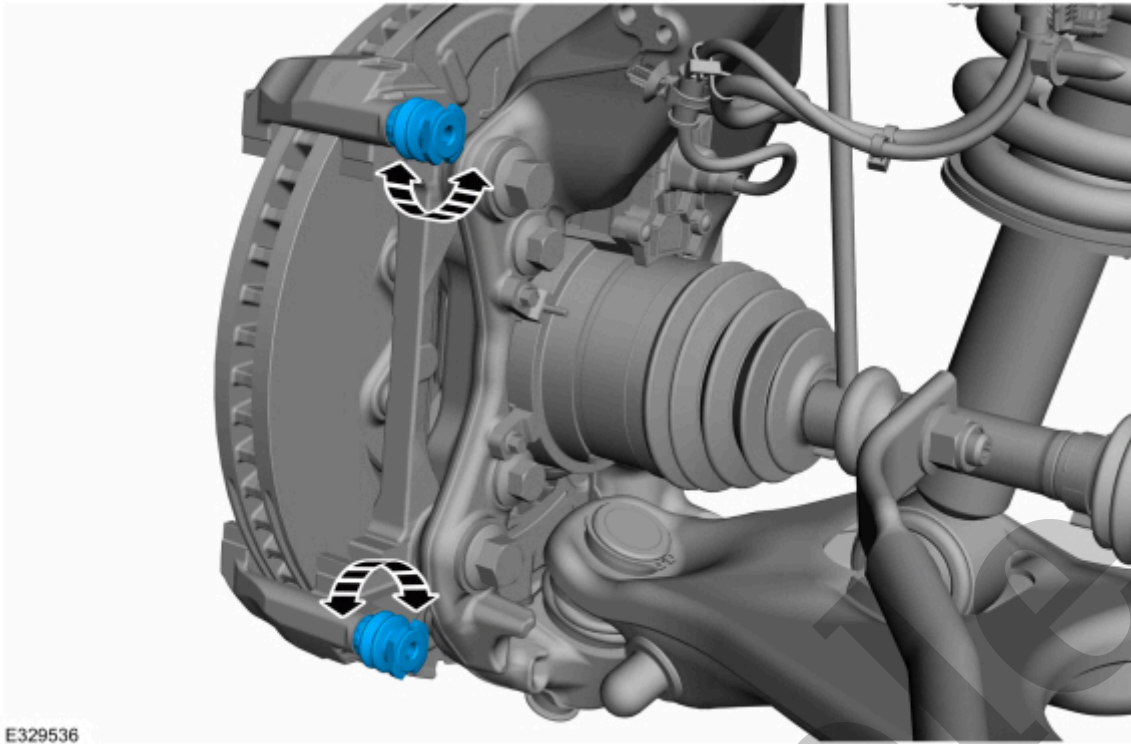

E329536

[Click here to learn about symbols, color coding, and icons used in this manual.](#)

6. **NOTE**

Make sure to position each guide rod flat parallel with the caliper anchor plate flats.

Position each guide rod flat parallel with the caliper anchor plate flat.

Bleed the brake system.

Refer to: [Brake System Pressure Bleeding](#)(206-00 Brake System - General Information, General Procedures).

Copyright © Ford Motor Company

Sample

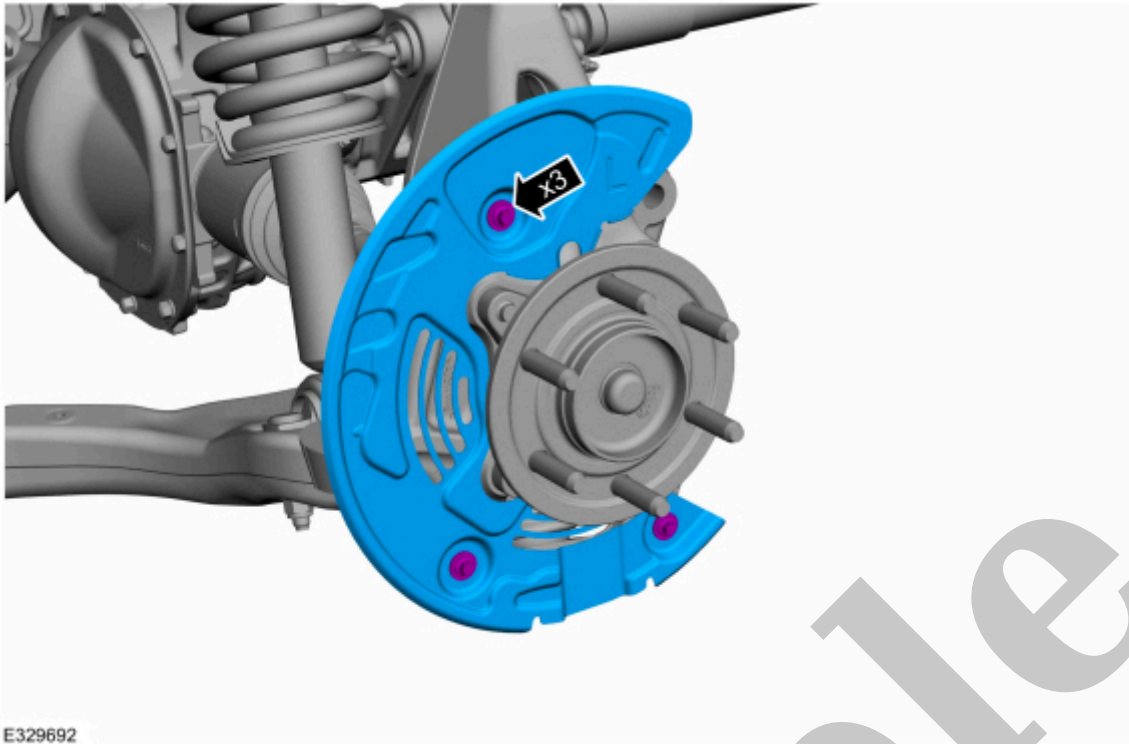

E329692

[Click here to learn about symbols, color coding, and icons used in this manual.](#)

### **Installation**

1. To install, reverse the removal procedure.

Copyright © Ford Motor Company

Remove the 2 anchor plate bolts and position the brake caliper and anchor plate assembly aside. Discard the bolts.

**Torque** : 184 lb.ft (250 Nm)

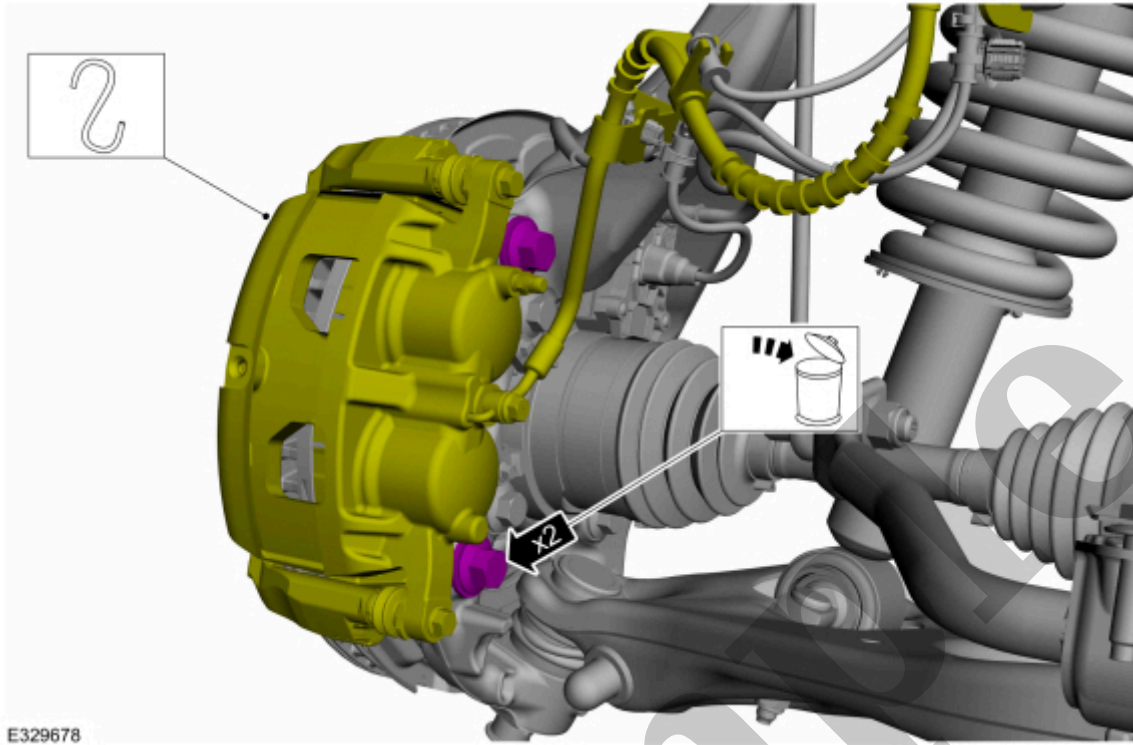

[Click here to learn about symbols, color coding, and icons used in this manual.](#)

4. Remove the brake disc.

[Click here to learn about symbols, color coding, and icons used in this manual.](#)

## 2. NOTICE

Make sure that the brake hose is not twisted when installing the brake caliper or damage to the brake flexible hose may occur.

To install, reverse the removal procedure.

## 3. Deactivate the brake service mode.

Refer to: [Brake Service Mode Activation and Deactivation](#)(206-00 Brake System - General Information, General Procedures).

## 4. Apply the brake pedal several times to verify correct brake system operation.

Copyright © Ford Motor Company

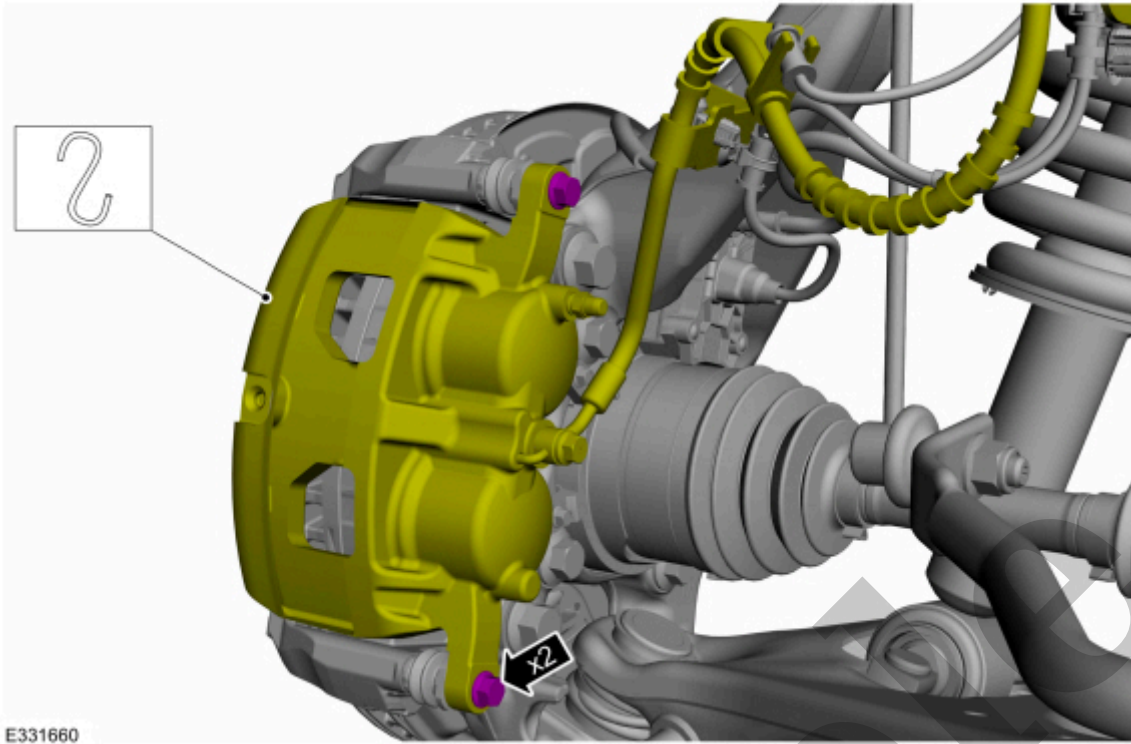

[Click here to learn about symbols, color coding, and icons used in this manual.](#)

4. Remove the brake pads.

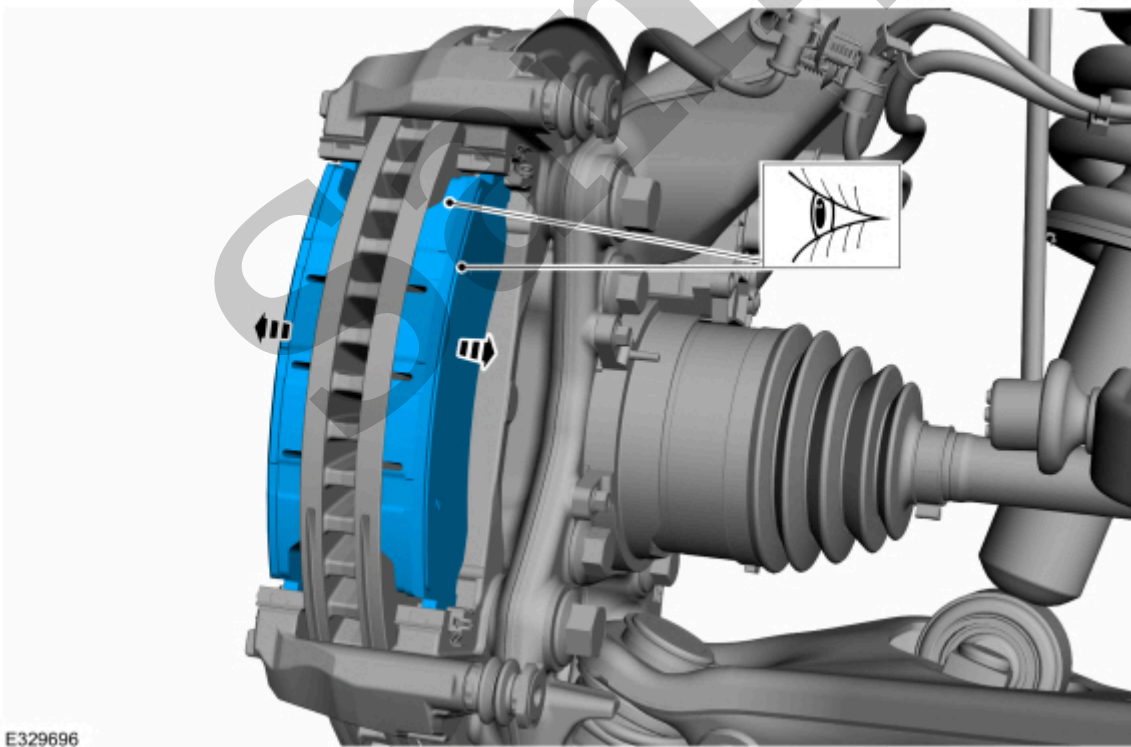

[Click here to learn about symbols, color coding, and icons used in this manual.](#)

5. Remove the brake pad clips. Discard if installing new brake pads.

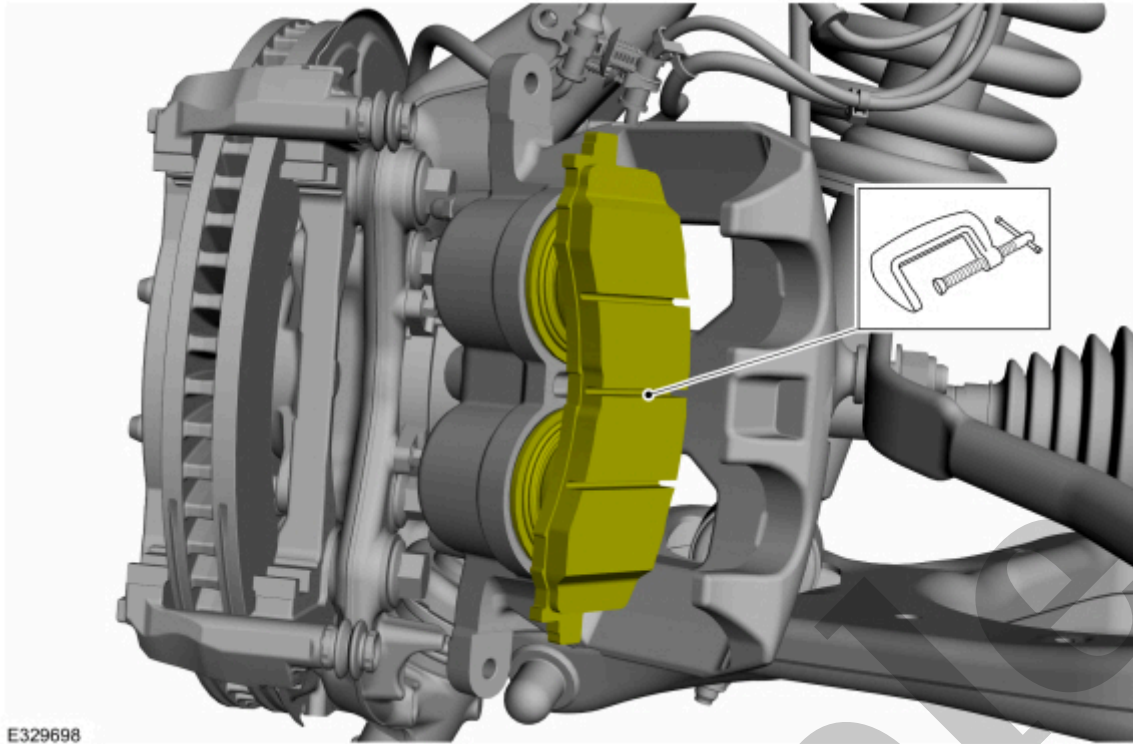

E329698

[Click here to learn about symbols, color coding, and icons used in this manual.](#)

## Installation

### 1. NOTE

Clips should sit flat against the bracket with the retraction leg loop toward the outside of bracket.

1. Install all clips with retraction leg loop toward outside of bracket. Center the abutment clips over the bracket recess.
2. Start to install the clip from the top rail.
3. Install the clip over the lower abutment.
4. Apply pressure with fingers to fully seat the clip against bracket.



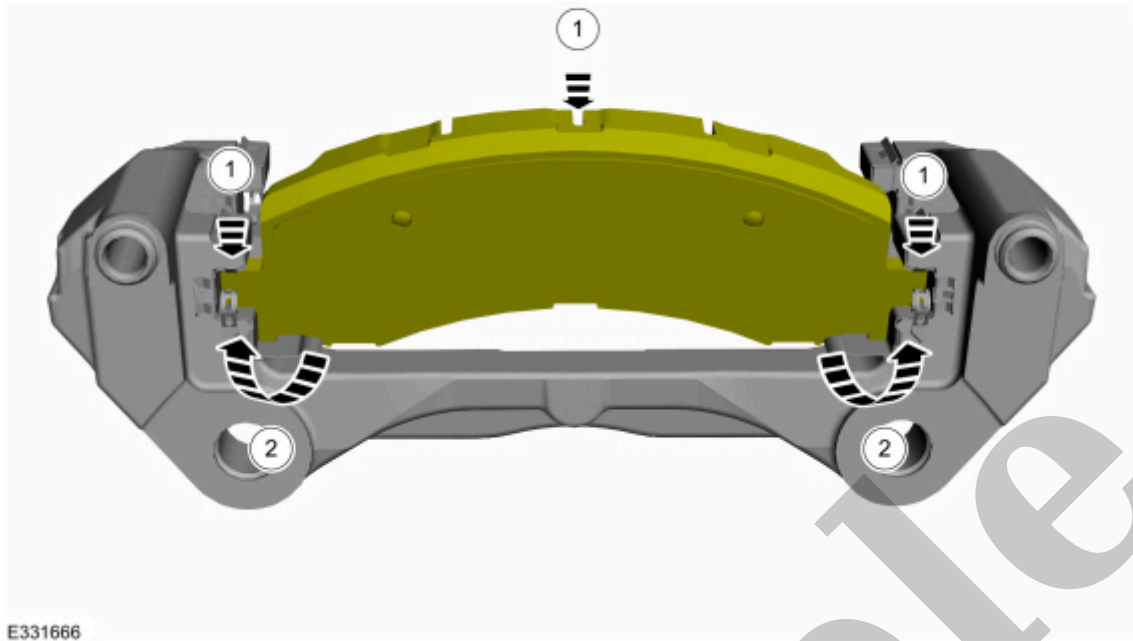

[Click here to learn about symbols, color coding, and icons used in this manual.](#)

#### NOTE

Below steps are required when guide rods do not move freely.

3. Clean the anchor plate bore using the specified material.

**Material** : Motorcraft® Metal Brake Parts Cleaner / PM-4-A, PM-4-B

5. 1. Install the guide rod boots onto the guide rods.
2. Make sure that the lip of the boot should be seated in the groove of the guide rod.

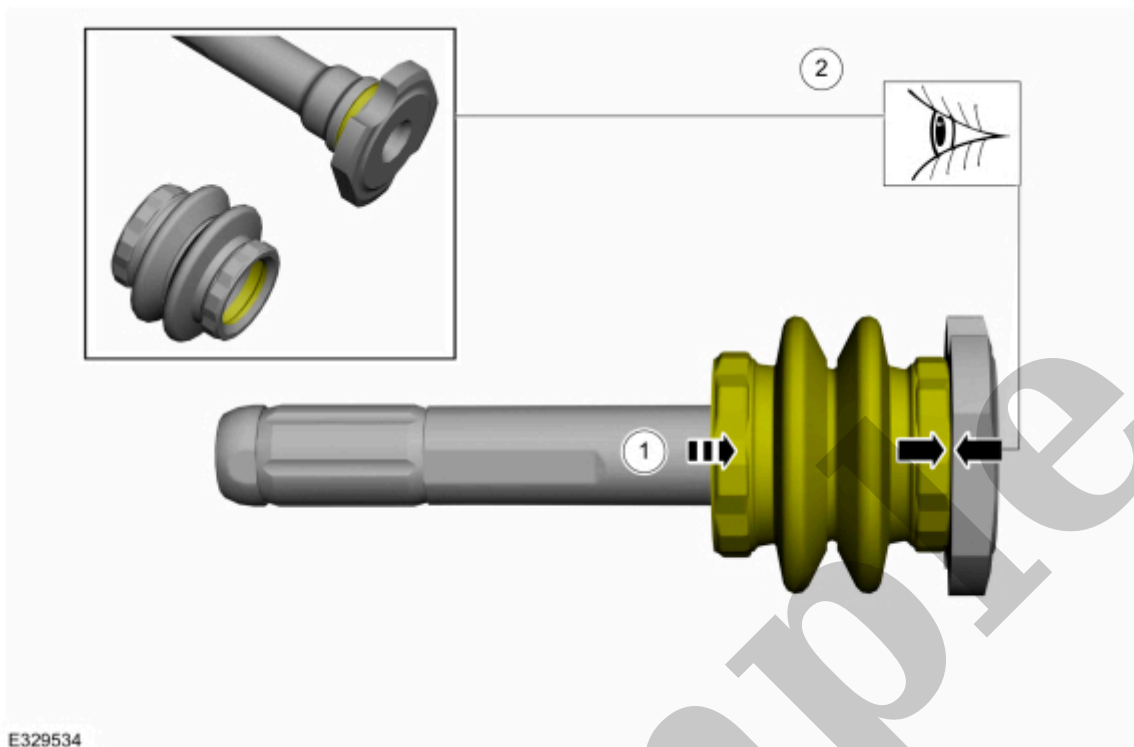

E329534

[Click here to learn about symbols, color coding, and icons used in this manual.](#)

6. Orient and push guide rod all the way into caliper anchor plate bore.

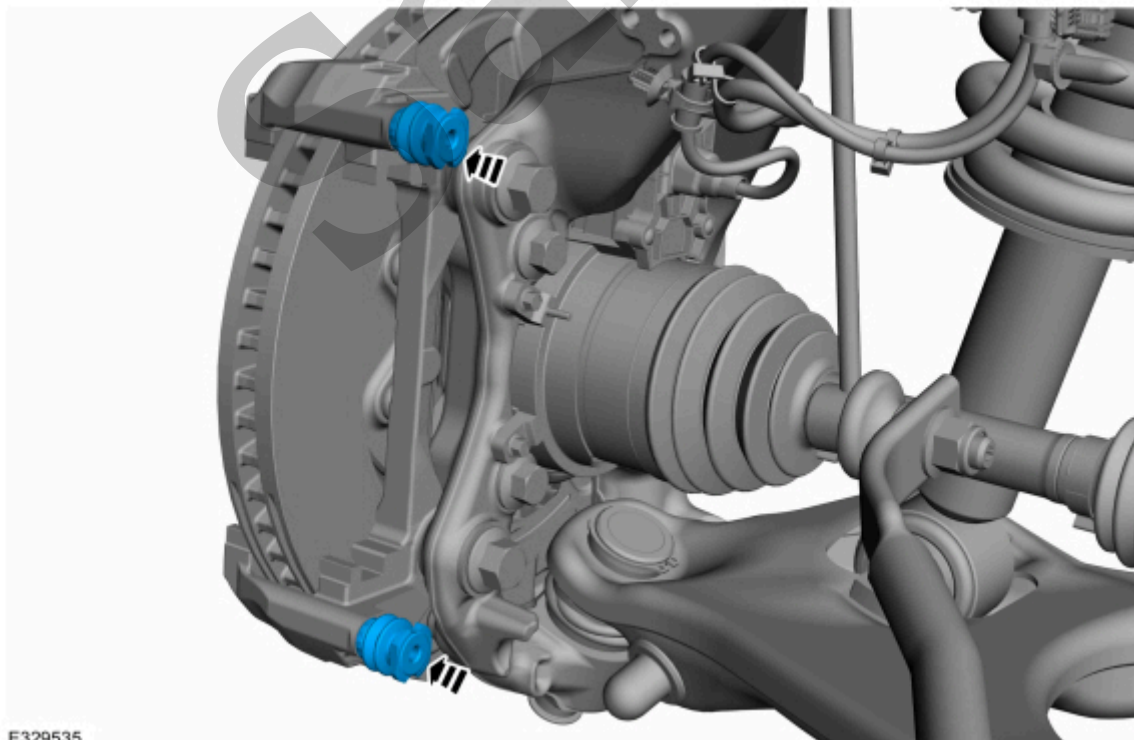

E329535