

Your Ultimate Source for OEM Repair Manuals

FactoryManuals.net is a great resource for anyone who wants to save money on repairs by doing their own work. The manuals provide detailed instructions and diagrams that make it easy to understand how to fix a vehicle.

2017 Ford F-550 Super Duty Service and Repair Manual

[Go to manual page](#)

Aftertreatment components consist of some or all of the following components: Catalytic Converters, Gasoline Particulate Filters, Diesel Particulate Filters, Selective Catalytic Reduction Catalysts, Exhaust Gas Heat Exchanger.

Diagnostics in this manual assume a certain skill level and knowledge of Ford-specific diagnostic practices.

REFER to: [Diagnostic Methods](#)

(100-00 General Information, Description and Operation).

Symptom Chart

Condition	Actions
Lack of power - vehicle performance complaint	<ul style="list-style-type: none">• GO to Pinpoint Test A
Odour from vehicle - possible sign of smoke	<ul style="list-style-type: none">• GO to Pinpoint Test B
Surface rust or degradation of surface treatment	<ul style="list-style-type: none">• GO to Pinpoint Test C
Noise such as buzzing, drumming, thumping, ringing or hissing coming from exhaust system	<ul style="list-style-type: none">• GO to Pinpoint Test D

Pinpoint Tests

PINPOINT TEST A : LACK OF POWER

NOTE

Aftertreatment components consist of some or all of the following: Catalytic Converters, Gasoline Particulate Filters, Diesel Particulate Filters, Selective Catalytic Reduction Catalysts.

Normal Operation and Fault Conditions

REFER to: [Exhaust System - Overview](#)(309-00B Exhaust System - 3.3L Duratec-V6, Description and Operation).

Possible Sources

- Exhaust pipe pinched or crushed
- Damaged aftertreatment components
- Loose obstruction in exhaust

- Rich fuel conditions
- Misfire conditions

Visual Inspection and Pre-checks

- Inspect for loose, damaged, contaminated or incorrect components.

B1 CHECK FOR DAMAGED AFTERTREATMENT COMPONENTS ASSOCIATED SENSORS

- Inspect the aftertreatment components and associated components for damage.

Have the aftertreatment components or associated electronic sensors incurred damage?

Yes	INSTALL a new aftertreatment components as necessary.
------------	---

No	GO to B2
-----------	--------------------------

B2 CHECK FOR INCORRECT FUEL OR FUEL WITH A HIGH SULFUR CONTENT

- Check the residual fuel in the fuel tank for incorrect fuel or fuel that contains a high sulfur content.

Does the fuel tank contain incorrect fuel or fuel high in sulfur content?

Yes	Drain the fuel tank and flush the fuel system. Refill the fuel system with fuel containing the correct level of sulfur.
------------	---

No	GO to B3
-----------	--------------------------

B3 CHECK FOR CORRECT PCM (POWERTRAIN CONTROL MODULE) OPERATION

- Using a diagnostic scan tool, perform the PCM self-test.

Are the powertrain controls operating correctly?

Yes	The condition may be intermittent. Advise the customer no repair is required.
------------	---

No	Correct and fix any powertrain control issues. Using a diagnostic scan tool, perform the PCM self-test. Test and confirm the issue has been resolved.
-----------	---

PINPOINT TEST D : NOISE FROM EXHAUST SYSTEM

NOTE

Aftertreatment components consist of some or all of the following: Catalytic Converters, Gasoline Particulate Filters, Diesel Particulate Filters, Selective Catalytic Reduction Catalysts.

Normal Operation and Fault Conditions

REFER to: [Exhaust System - Overview](#)(309-00B Exhaust System - 3.3L Duratec-V6, Description and Operation).

Possible Sources

- Loose or damaged heat shield(s)
- Loose or damaged exhaust isolators(s)
- Damaged exhaust isolator hanger bracket
- Loose or damaged aftertreatment components or mufflers
- Exhaust system leak
- Catalytic converter/exhaust system
- Exhaust system grounded to chassis
- Damaged or worn exhaust system
- Misaligned exhaust system
- Strain on the exhaust system

Visual Inspection and Pre-checks

- Inspect for loose, damaged, contaminated or incorrect components.

D1 CHECK THE EXHAUST SYSTEM FASTENERS

- Check and confirm that all exhaust system fasteners on joining connections, hanger brackets and isolators are tightened to specification.

Was exhaust noise still present after confirming all exhaust system fasteners are tightened to specification?

Yes

GO to [D2](#)

No

The issue has been resolved.

D2 INSPECT THE EXHAUST ISOLATORS AND HANGER BRACKETS

- Visually inspect the condition and alignment of all exhaust system isolators and hanger brackets.

Yes	The exhaust component likely has internal damage. INSTALL new components as necessary.
------------	--

No	GO to D6
-----------	--------------------------

D6 CHECK THE EXHAUST SYSTEM FOR LEAKS

- With the engine running, visually inspect the exhaust components and pipework for leaks.

Were leaks found?

Yes	INSTALL new components as necessary.
------------	--------------------------------------

No	GO to D7
-----------	--------------------------

D7 CHECK FOR COOL DOWN PINGING

- Run the engine and bring the exhaust system to operating temperature.
- KOEO (key on, engine off)
- While allowing the engine to cool, listen the exhaust system during cool down to attempt to isolate the noise complaint.

Was the exhaust complaint found to be cool down pinging?

Yes	Cool down pinging is a result of the exhaust system expanding and contracting during heating and cooling. This is a normal condition. The issue has been resolved.
------------	--

No	The condition may be intermittent. Advise the customer no repair is required.
-----------	---

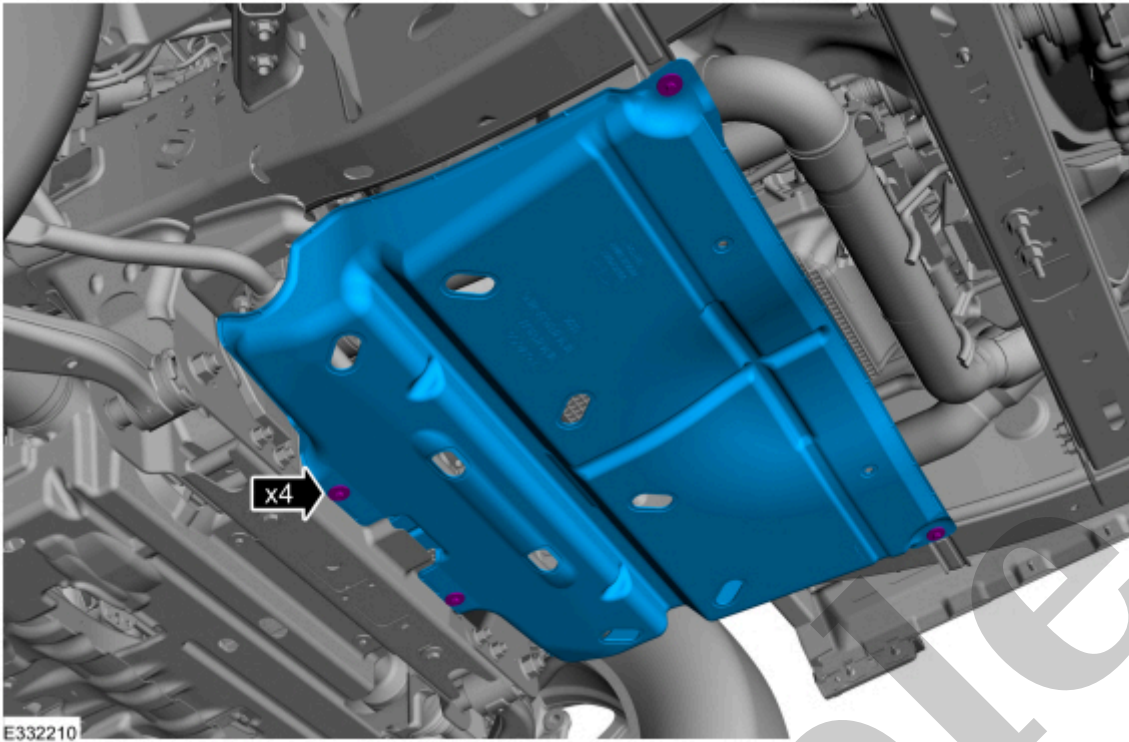

E332210

[Click here to learn about symbols, color coding, and icons used in this manual.](#)

3. Disconnect the electrical connectors and detach the wire clips.

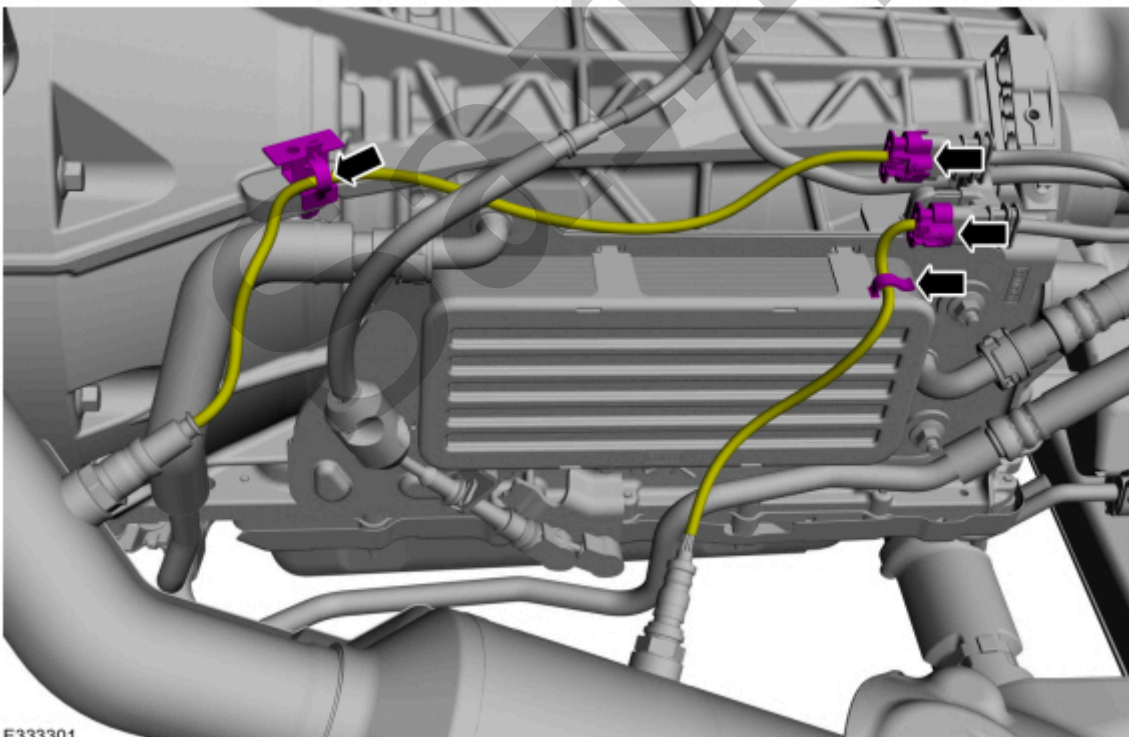

E333301

[Click here to learn about symbols, color coding, and icons used in this manual.](#)

4. Remove the LH (left-hand) catalytic converter nuts and discard.

6. NOTE

This step is only required if you are replacing with new components.

Apply penetrating oil to sensor. Using the special tool, remove the HO2S (heated oxygen sensor) and the catalyst monitor sensors.

Use Special Service Tool : 303-476 (T94P-9472-A) Socket, Exhaust Gas Oxygen Sensor

Material : Motorcraft® Penetrating and Lock Lubricant / XL-1

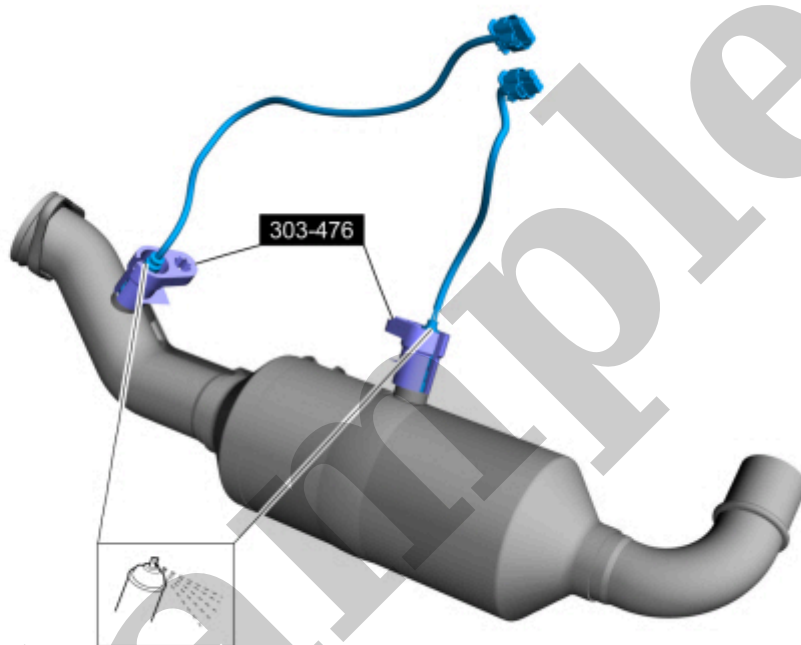

E333304

[Click here to learn about symbols, color coding, and icons used in this manual.](#)

Installation

1. Clean all exhaust connections before reassembly.

2. NOTE

This step is only required if you are replacing with new components.

Apply anti-seize to thread of sensor. Using the special tool, install the HO2S (heated oxygen sensor) and the catalyst monitor sensors.

Use Special Service Tool : 303-476 (T94P-9472-A) Socket, Exhaust Gas Oxygen Sensor

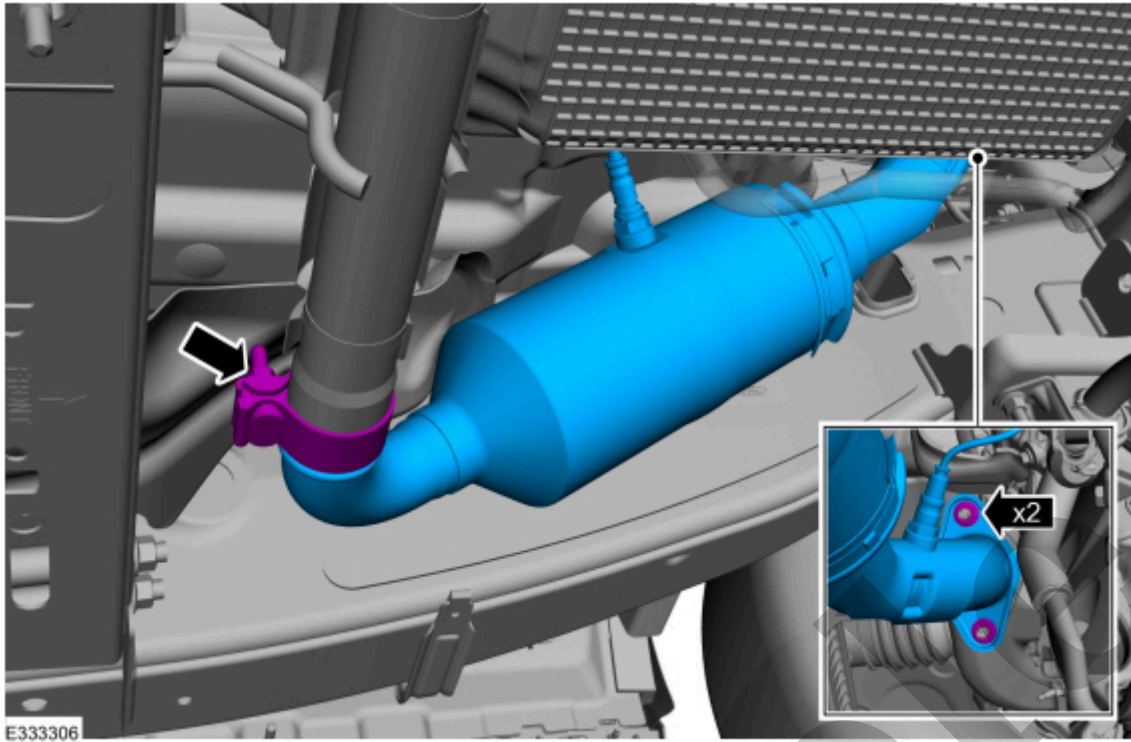

[Click here to learn about symbols, color coding, and icons used in this manual.](#)

4. **NOTE**

Evenly tighten the LH (left-hand) catalytic converter nuts.

Tighten the LH (left-hand) catalytic converter nuts.

Torque : 30 lb.ft (40 Nm)

6. Connect the electrical connectors and attach the wire clips.

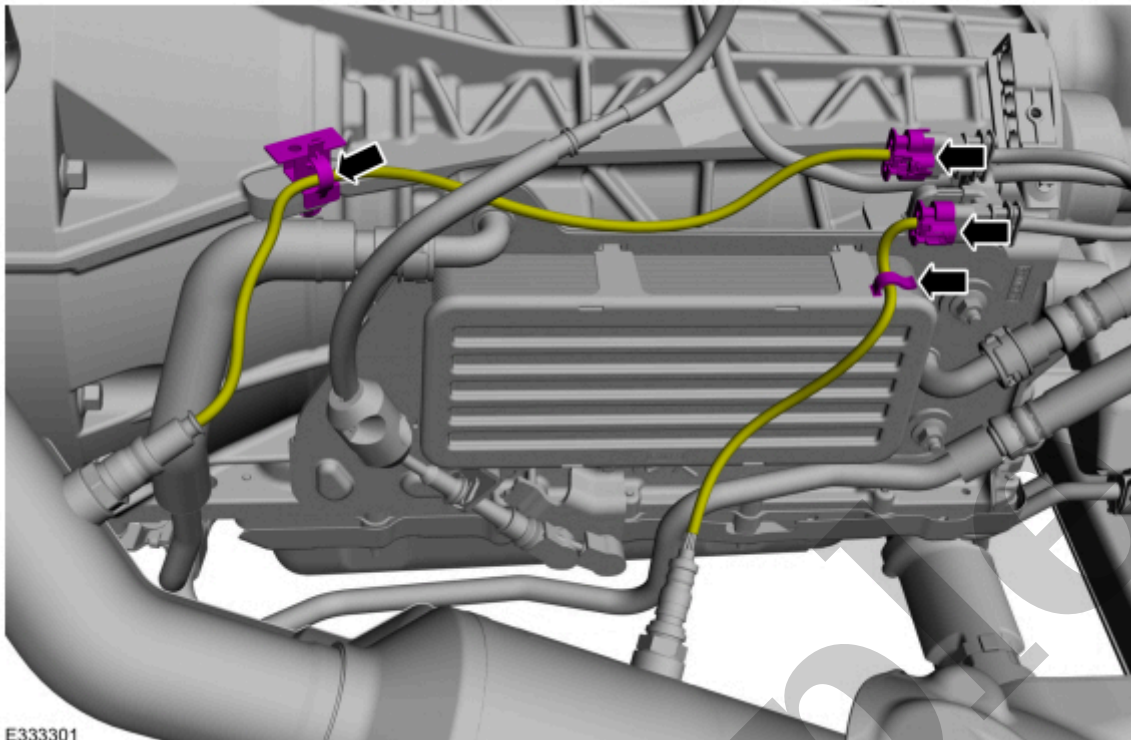

E333301

[Click here to learn about symbols, color coding, and icons used in this manual.](#)

7. If equipped, install the underbody shield.

Torque : 71 lb.in (8 Nm)

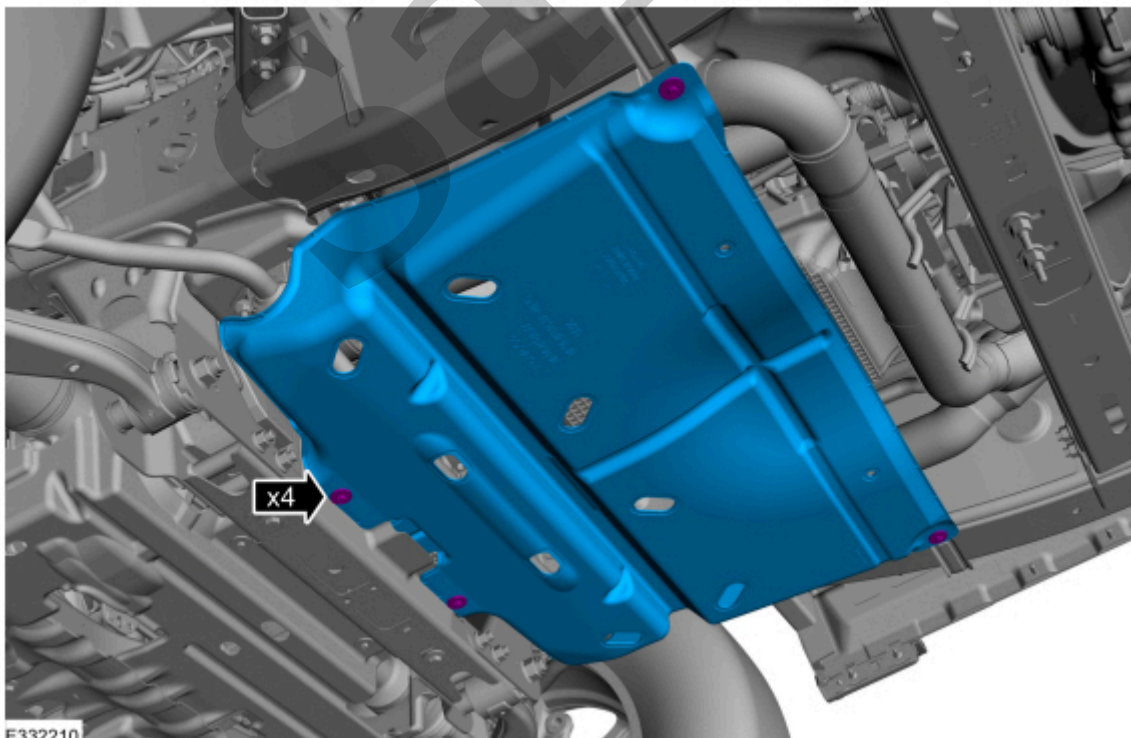

E332210

Catalytic Converter RH

309-00B Exhaust System - 3.3L Duratec-V6	2022 F-150
Removal and Installation	Procedure revision date: 07/22/2020

Catalytic Converter RH

Removal

NOTE

If the catalytic converter is not being replaced, the HO2S and the catalyst monitor sensor do not need to be removed from the catalytic converter. Disconnecting the electrical connectors is still necessary.

NOTE

The exhaust Y-pipe dual catalytic converter is a 2-piece assembly. The LH (left-hand) and RH (right-hand) converters can be serviced separately as needed.

1. With the vehicle in NEUTRAL, position it on a hoist.

Refer to: [Jacking and Lifting - Overview](#)(100-02 Jacking and Lifting, Description and Operation).

2. Remove the LH catalytic converter.

Refer to: [Catalytic Converter LH](#)(309-00B Exhaust System - 3.3L Duratec-V6, Removal and Installation).

3. Remove the muffler inlet pipe.

Refer to: [Muffler Inlet Pipe](#)(309-00B Exhaust System - 3.3L Duratec-V6, Removal and Installation).

4. Disconnect the electrical connectors and detach the wire clips.