

Your Ultimate Source for OEM Repair Manuals

FactoryManuals.net is a great resource for anyone who wants to save money on repairs by doing their own work. The manuals provide detailed instructions and diagrams that make it easy to understand how to fix a vehicle.

2016 TOYOTA Prius OEM Service and Repair Workshop Manual

[Go to manual page](#)

(d) Remove the transmission wire (4) for terminal 50 from the starter assembly.

(e) Unclip the transmission wire (1) from the oil pan cover in the marked areas.

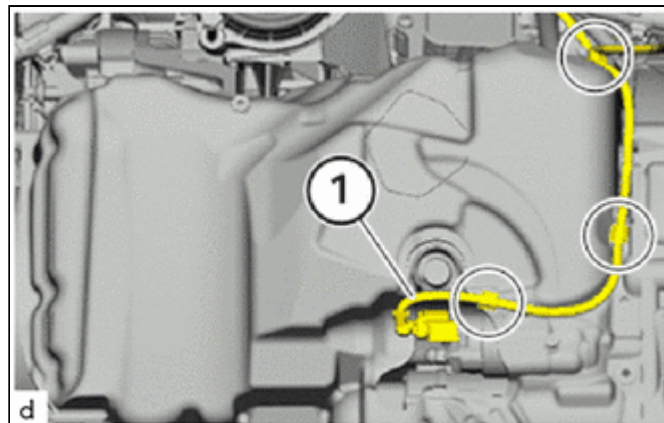

(f) Remove the clip (1).

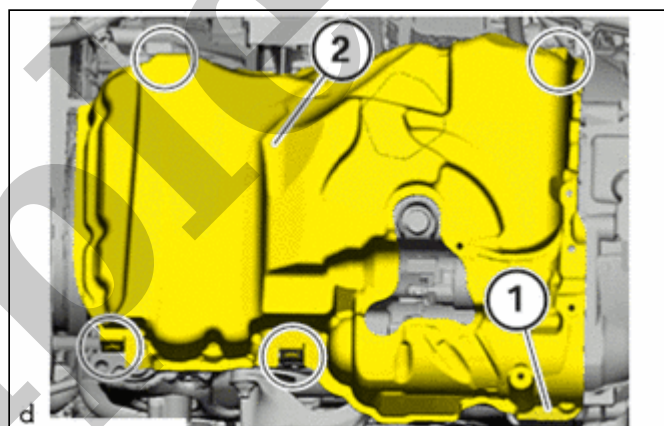

(g) Remove the clips in the marked areas.

NOTICE:

- Bending of plastic parts.

Application of too much force can lead to bending of plastic parts.

- Place special tool directly beside the mounting clip.
- Continue unclipping the part without using the tool if possible.

(h) Slightly lower the oil pan cover (2), slide forward and place it on the front axle support.

4. REMOVE STARTER ASSEMBLY

(a) Loosen E10 bolts (1).

Last Modified: 07-26-2024	6.11:8.1.0	Doc ID: RM100000001R4XH
Model Year Start: 2021	Model: Supra	Prod Date Range: [07/2020 -]
Title: B48 (STARTING): STARTER: INSTALLATION; 2021 - 2025 MY Supra [07/2020 -]		

INSTALLATION

PROCEDURE

1. INSTALL STARTER COVER

(a) Install the starter cover to the starter assembly.

2. INSTALL STARTER ASSEMBLY

(a) Insert and install the starter assembly (2).

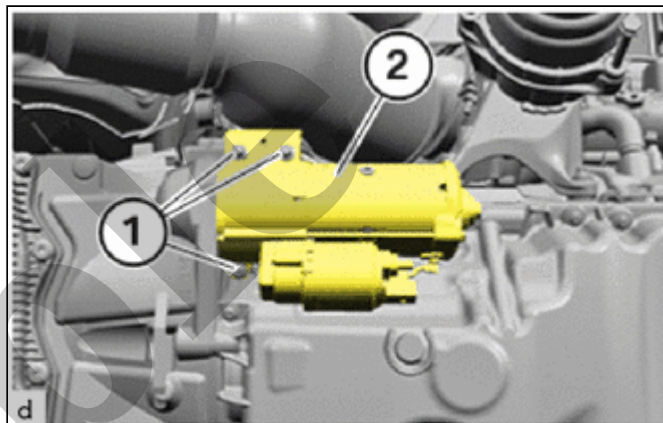

(b) Tighten the E10 bolts (1).

Torque:

19 N·m {194 kgf·cm, 14 ft·lbf}

3. INSTALL OIL PAN COVER

CAUTION:

- Improper routing of the positive battery cable.
- Risk of short circuits!
 - Route the positive battery cable without abrasions and do not trap.

(a) Position the oil pan cover (2).

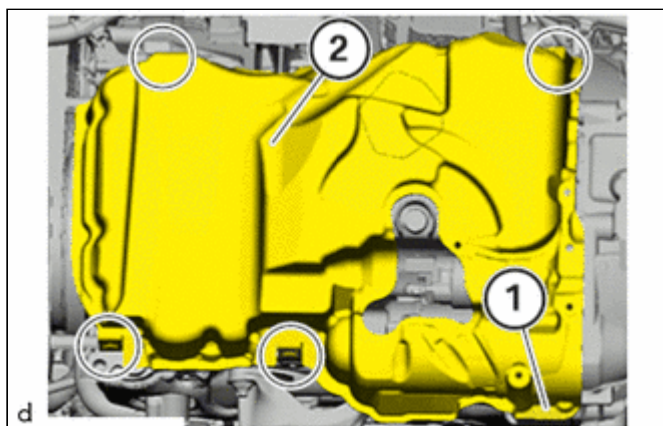

(b) Replace the clip (1).

(c) Install the clip (1).

Last Modified: 07-26-2024	6.11:8.1.0	Doc ID: RM100000001R4XI
Model Year Start: 2021	Model: Supra	Prod Date Range: [07/2020 -]
Title: B48 (STARTING): STARTER WIRING ASSEMBLY: COMPONENTS; 2021 - 2025 MY Supra [07/2020 -]		

COMPONENTS

ILLUSTRATION

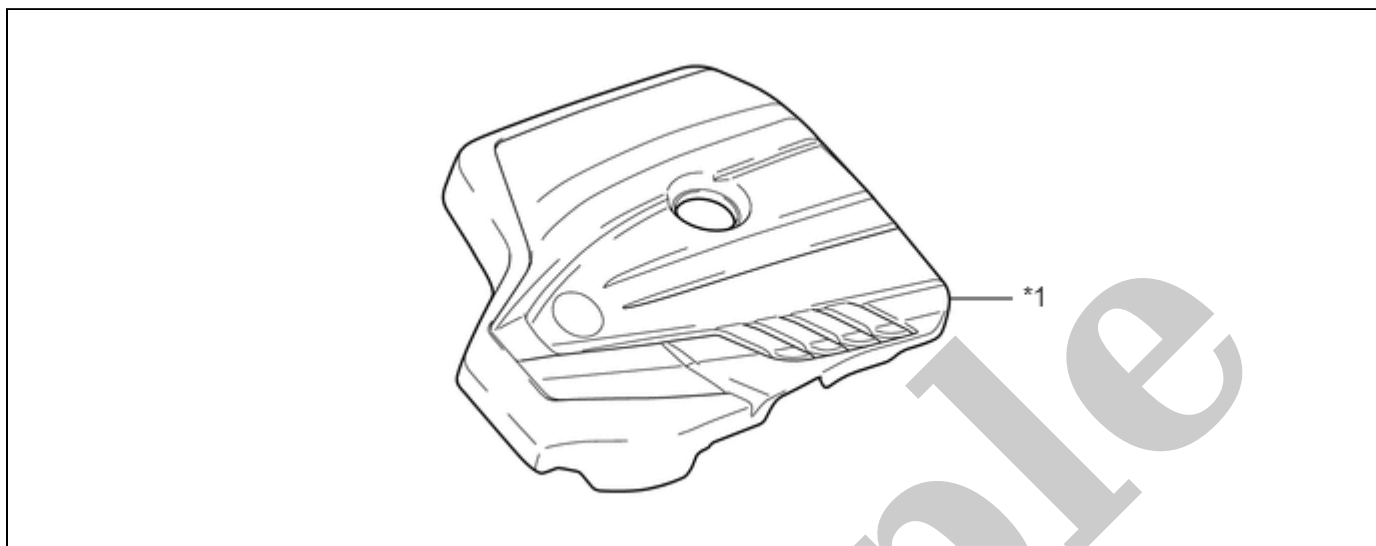

*1	NO. 1 ENGINE COVER SUB-ASSEMBLY	-	-
----	---------------------------------	---	---

ILLUSTRATION

Sample

Last Modified: 07-26-2024	6.11:8.1.0	Doc ID: RM100000001R4XJ
Model Year Start: 2021	Model: Supra	Prod Date Range: [07/2020 -]
Title: B48 (STARTING): STARTER WIRING ASSEMBLY: REMOVAL; 2021 - 2025 MY Supra [07/2020 -]		

REMOVAL

CAUTION / NOTICE / HINT

CAUTION:

- Working on 12 V vehicle electrical system.
 - Risk of short circuits! Risk of fire!
 - Disconnect the cable from the negative (-) battery terminal.
- Hot surfaces.
 - Risk of burning!
 - Perform all work only on components that have cooled down.

PROCEDURE

1. DISCONNECT CABLE FROM NEGATIVE BATTERY TERMINAL

Click here [INFO](#)

2. REMOVE NO. 1 ENGINE COVER SUB-ASSEMBLY

Click here [INFO](#)

3. REMOVE FRONT SUSPENSION MEMBER LOWER PROTECTOR

Click here [INFO](#)

4. REMOVE STARTER WIRING ASSEMBLY

(a) Unlock the locks (1).

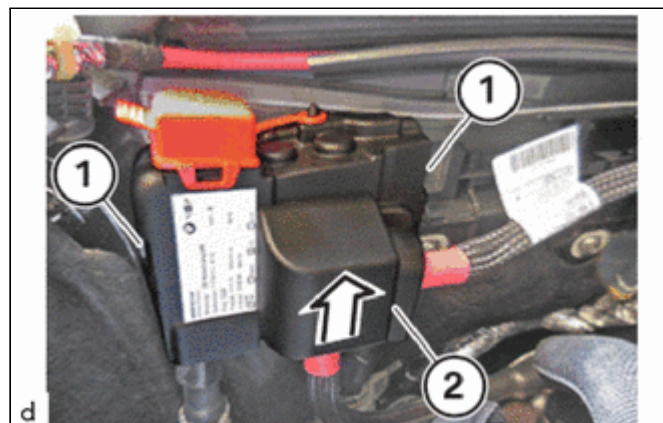

(b) Guide and remove terminal cover (2) in the direction of the arrow.

(c) Unfasten nut (1).