

Your Ultimate Source for OEM Repair Manuals

FactoryManuals.net is a great resource for anyone who wants to save money on repairs by doing their own work. The manuals provide detailed instructions and diagrams that make it easy to understand how to fix a vehicle.

2015 VOLVO V60 OEM Service and Repair Workshop Manual

[Go to manual page](#)

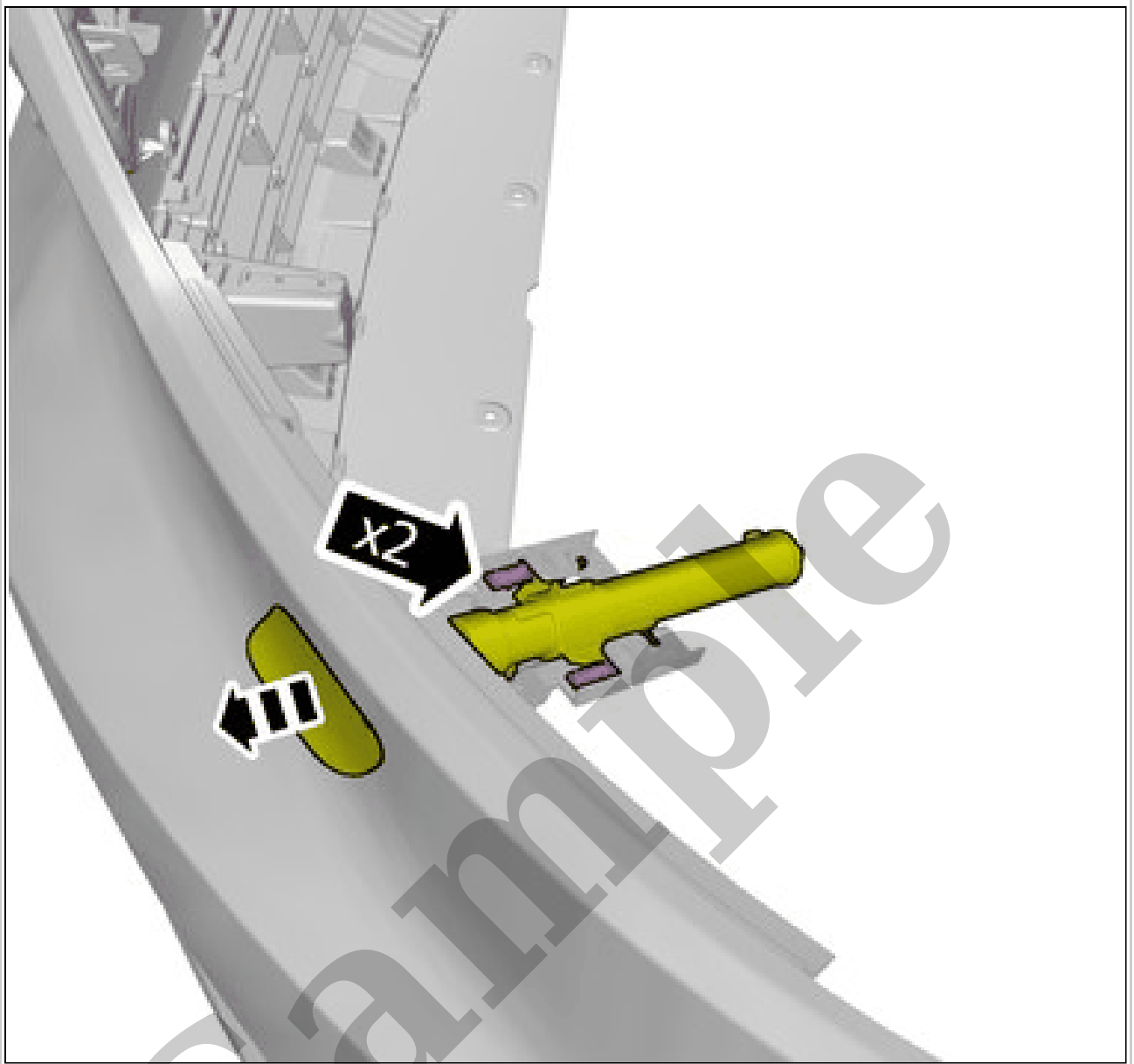

Courtesy of VOLVO CARS CORPORATION

Remove the part carefully
Repeat on the other side.

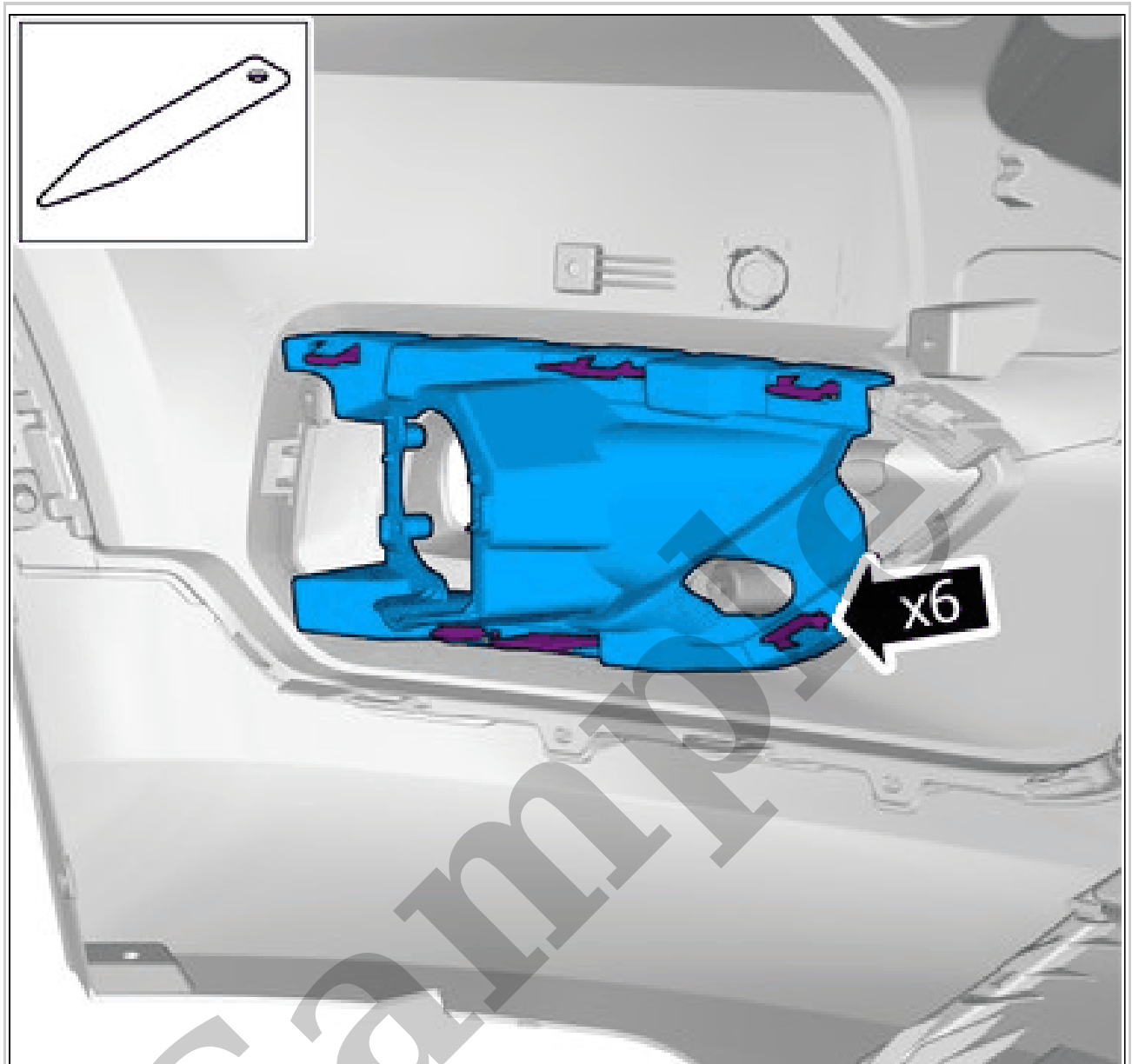

Courtesy of VOLVO CARS CORPORATION

- Release the catches.
- Remove the marked part.
- Repeat on the other side.

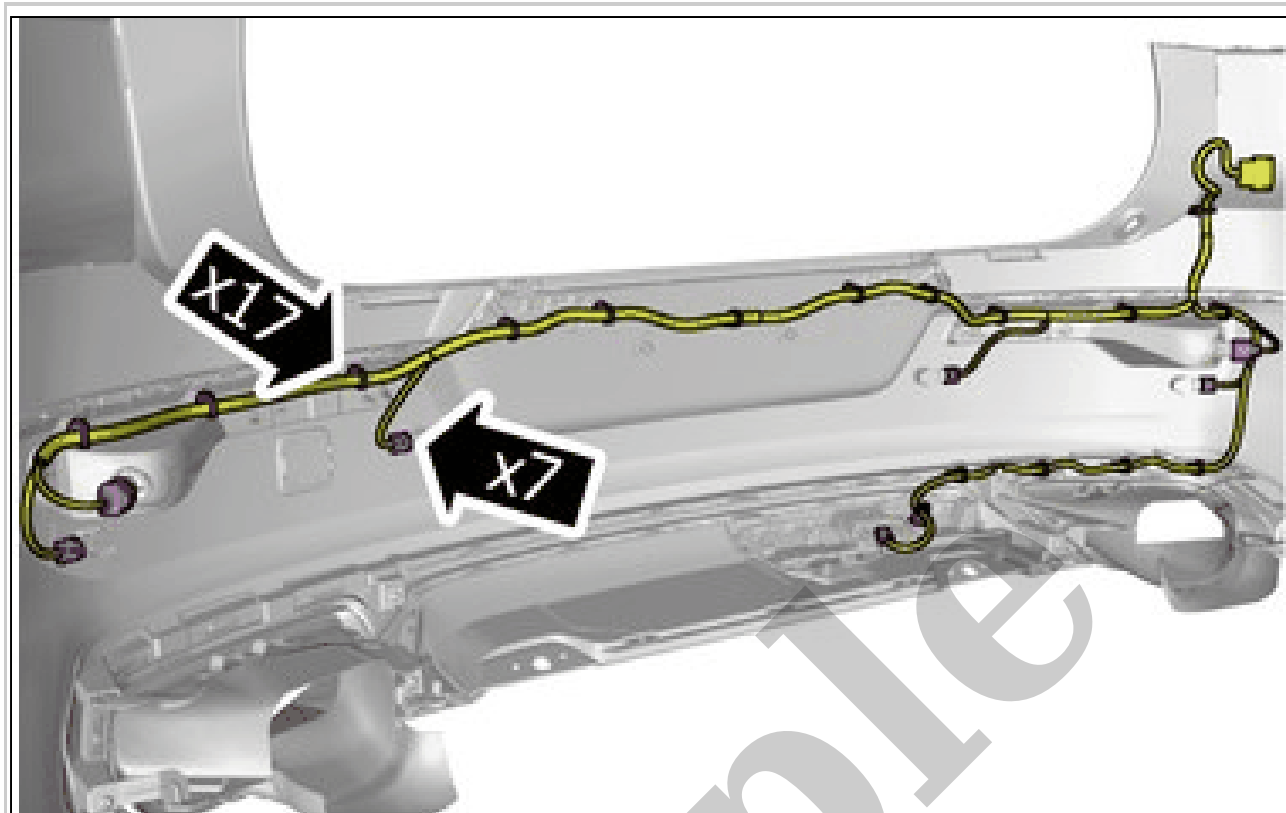

Courtesy of VOLVO CARS CORPORATION

NOTE: *The number of connectors may vary depending on the vehicle's equipment level.*

Remove the cable harness clips.
Disconnect the connectors.

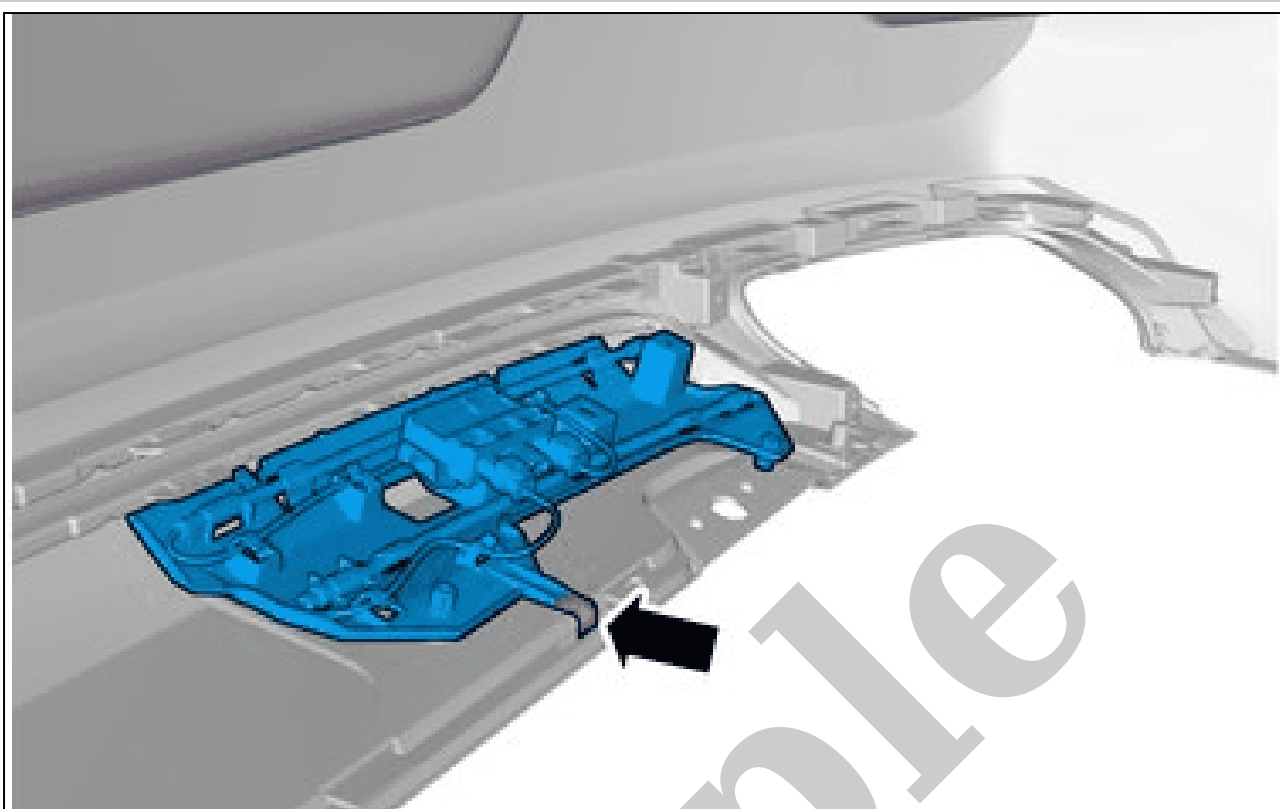

Courtesy of VOLVO CARS CORPORATION

Release the catch.
Remove the marked part.

Sample

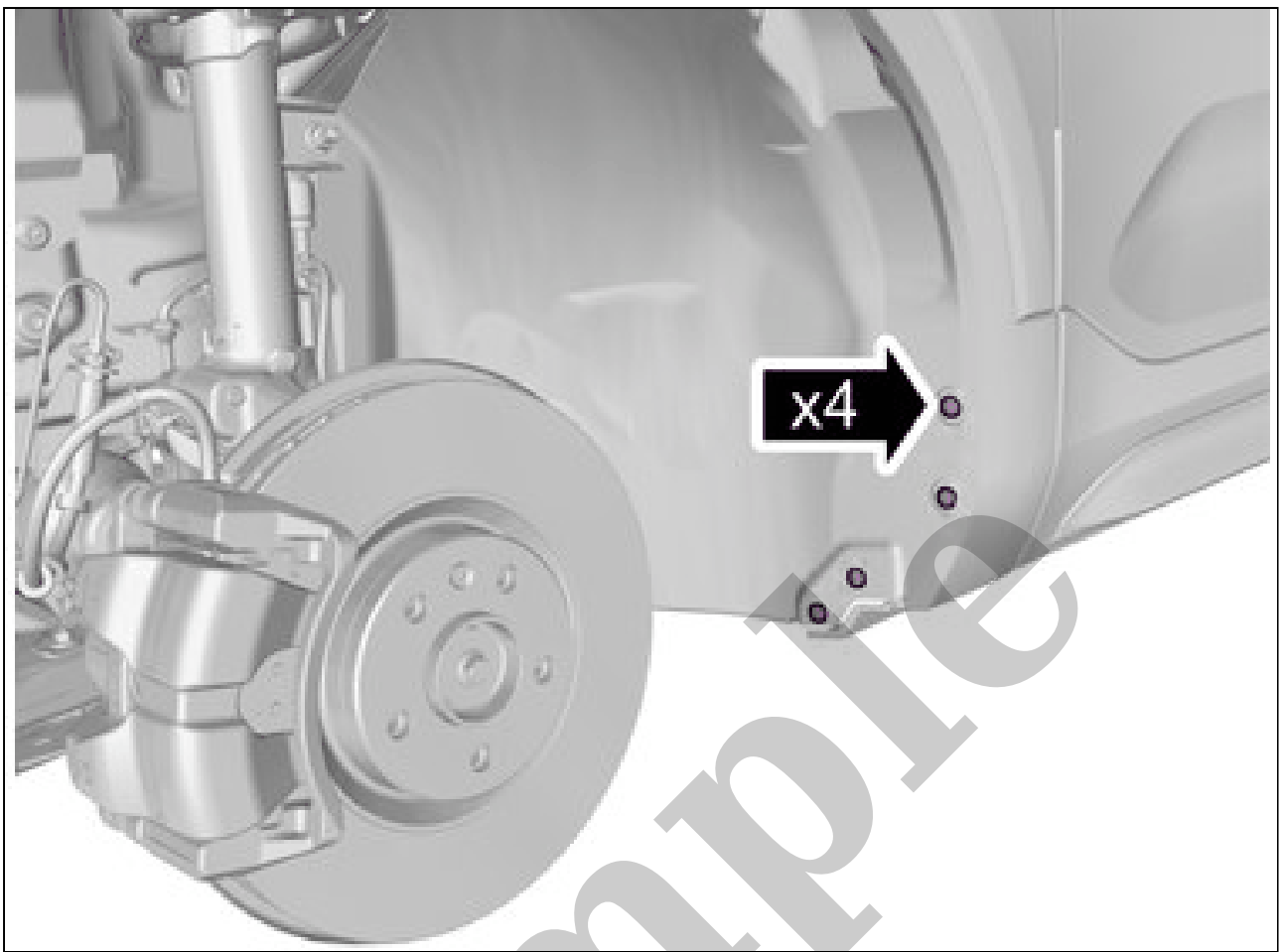

Courtesy of VOLVO CARS CORPORATION

Remove the screws.

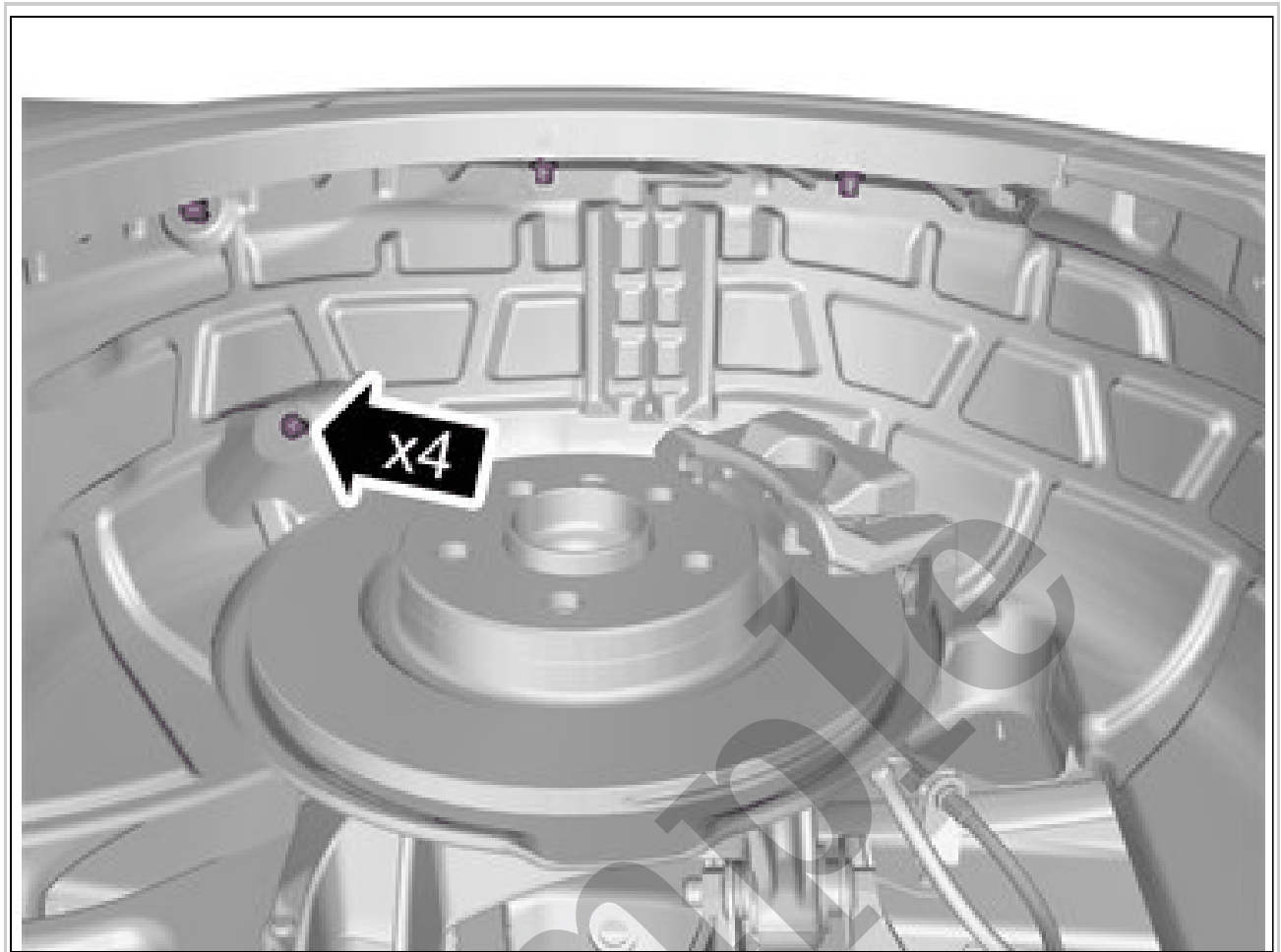

Courtesy of VOLVO CARS CORPORATION

Remove the nuts.

HEATED RADAR COVER > HEATED RADAR COVER (9/81) [2021-2022, E400V6] > CONNECTION AND COMMUNICATION

The heated radar cover is directly connected to the Central Electronic Module (CEM).

HEATER, WINDSHIELD > HEATER, WINDSHIELD (9/7) [2018-2022] > DESCRIPTION

The heating loops in the heater windshield heats up when they are supplied with power via the relay in the Central Electronic Module (CEM).

HEATER, WINDSHIELD > HEATER, WINDSHIELD (9/7) [2018-2022] > DIAGNOSTIC INFORMATION

The heater windshield does not have a built-in diagnostic system. The Central Electronic Module (CEM) monitors the heater windshield, sets DTCs and stores readable parameters.

HEATER, WINDSHIELD > HEATER, WINDSHIELD (9/7) [2018-2022] > CONNECTION AND COMMUNICATION

The heater windshield is directly connected to the Central Electronic Module (CEM).

HEATER REAR WINDOW > HEATER REAR WINDOW (9/2) [2018-2022] > DESCRIPTION

The heating loops in the rear window glass heat up when they are supplied with power via a relay in the Central Electronic Module (CEM).

HEATER REAR WINDOW > HEATER REAR WINDOW (9/2) [2018-2022] > DIAGNOSTIC INFORMATION

The heater rear window does not have a built-in diagnostic system. The Central Electronic Module (CEM) monitors the heater rear window, sets DTCs, and stores readable parameters.

HEATER REAR WINDOW > HEATER REAR WINDOW (9/2) [2018-2022] > CONNECTION AND COMMUNICATION

The heater rear window is directly connected to the Central Electronic Module (CEM).

MOTOR, EXTERNAL MIRROR ADJUSTMENT > MOTOR, EXTERNAL MIRROR ADJUSTMENT [2018-2022] > DESCRIPTION

The motor, external mirror adjustment, has the following functions:

- Vertical and horizontal mirror position adjustment
- Mirror position memory
- Mirror dip at reverse



Courtesy of VOLVO CARS CORPORATION

Sample

Drill first layer only

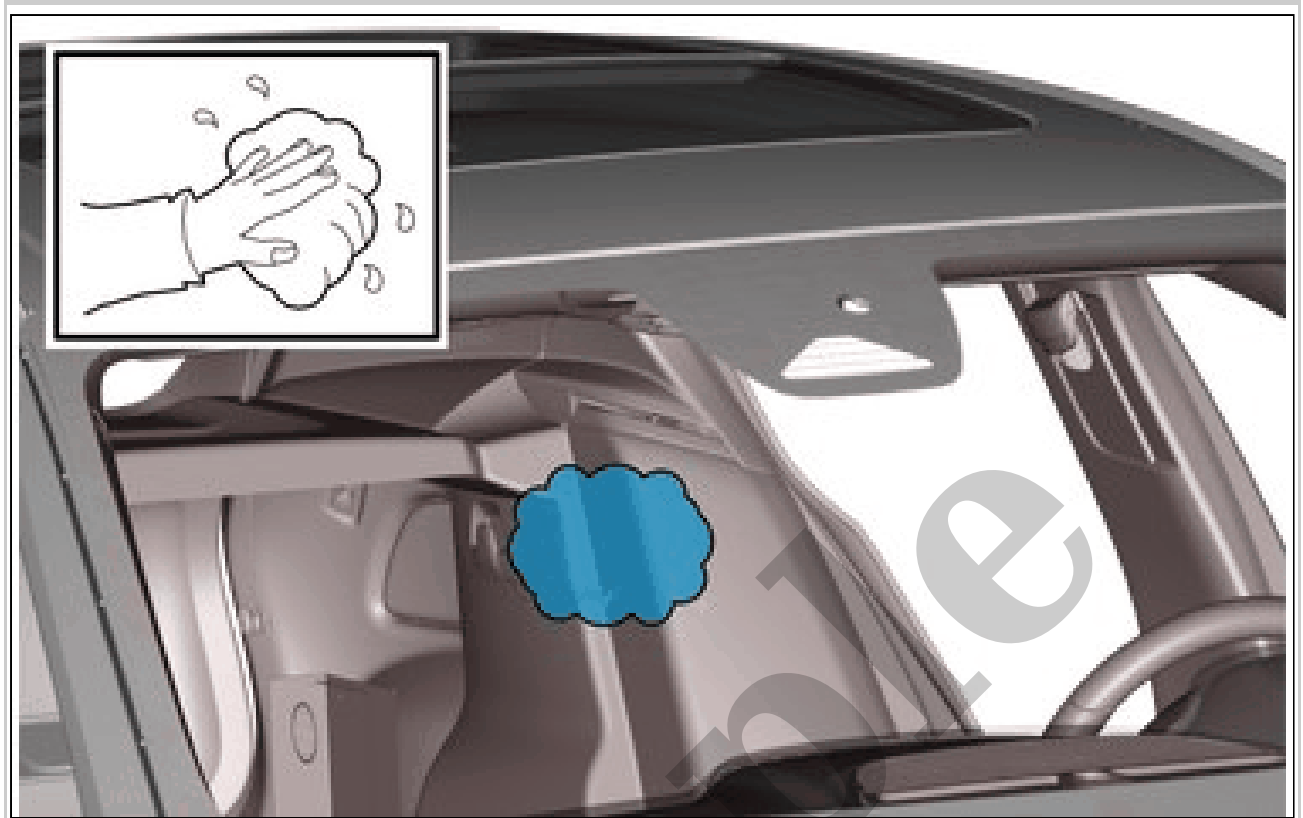

Courtesy of VOLVO CARS CORPORATION

Sample