

Your Ultimate Source for OEM Repair Manuals

FactoryManuals.net is a great resource for anyone who wants to save money on repairs by doing their own work. The manuals provide detailed instructions and diagrams that make it easy to understand how to fix a vehicle.

2015 VOLVO S60 OEM Service and Repair Workshop Manual

[Go to manual page](#)

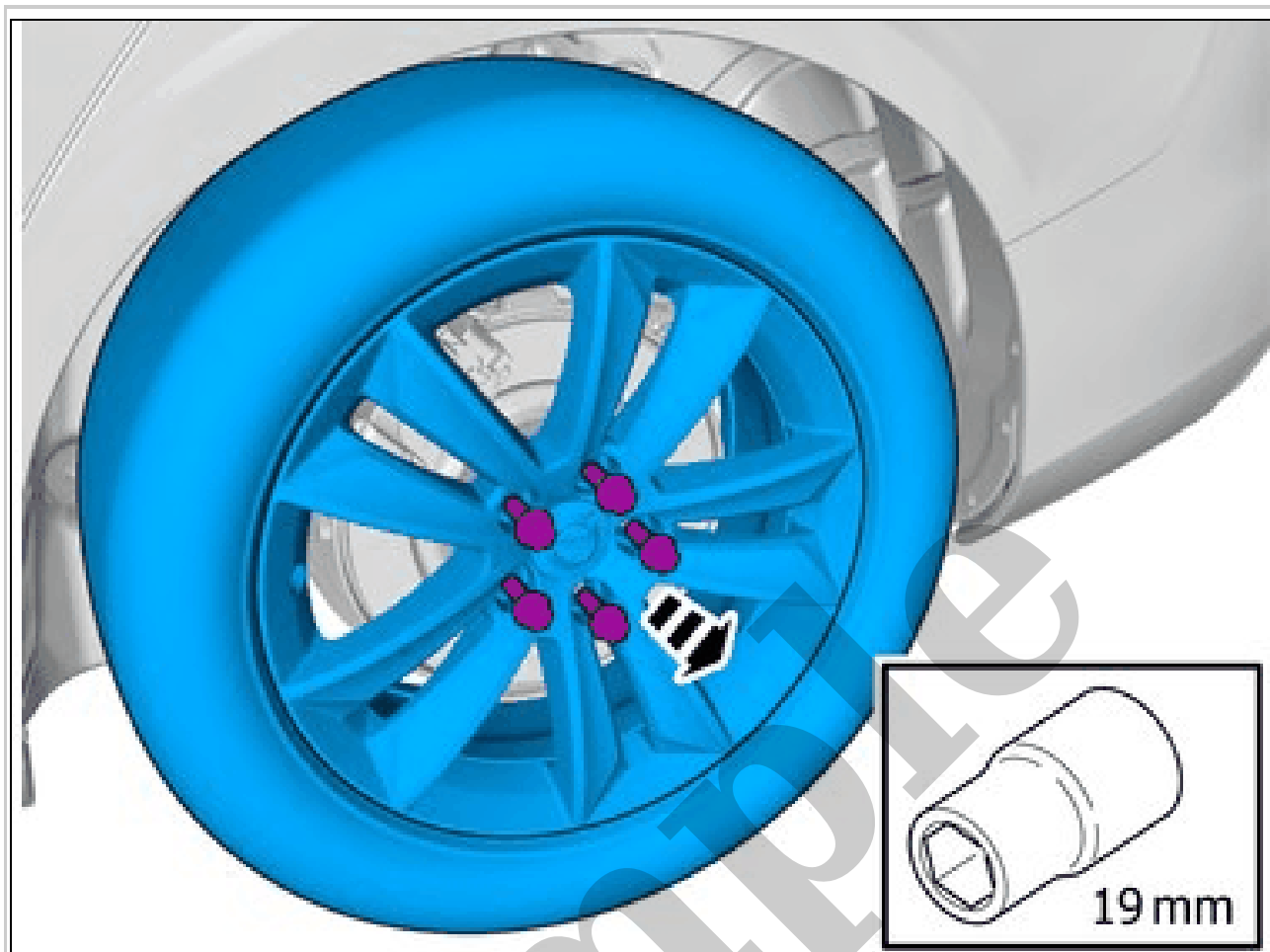

Courtesy of VOLVO CARS CORPORATION

Remove the marked part.

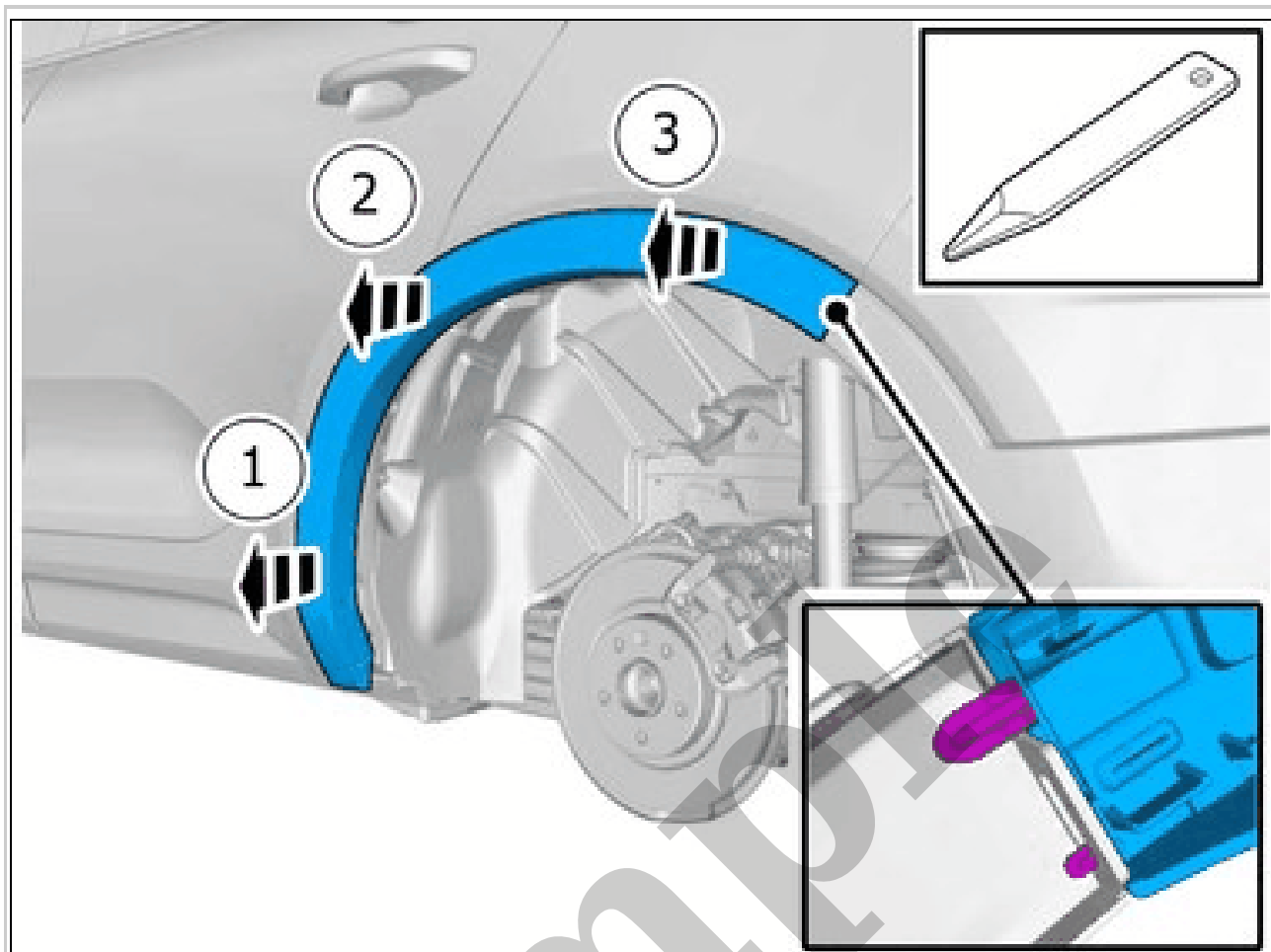

Courtesy of VOLVO CARS CORPORATION

CAUTION: Make sure not to damage painted surfaces.

Remove the marked part.
Use: Interior trim remover

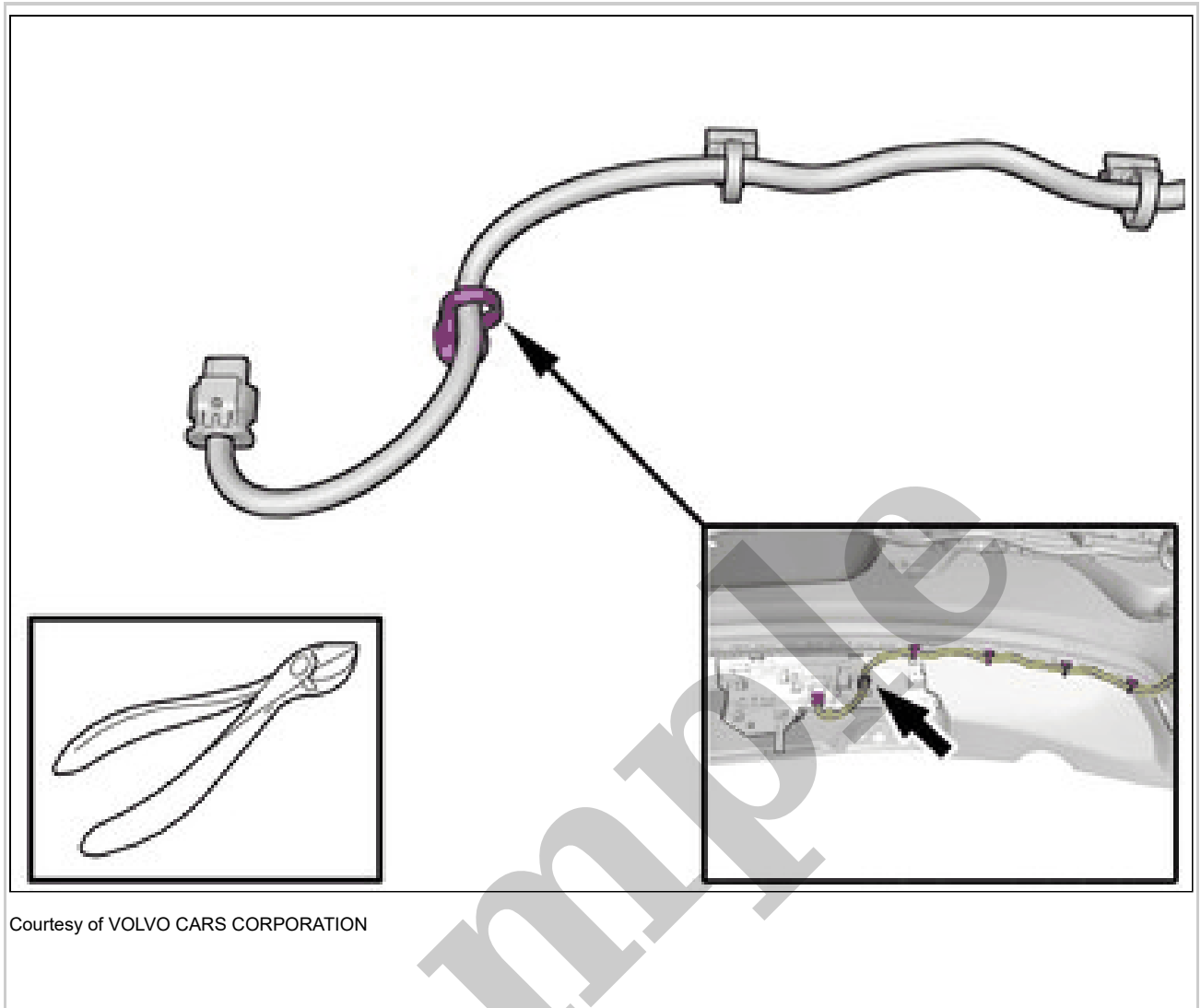

Courtesy of VOLVO CARS CORPORATION

Remove the clip.
Use: Pliers

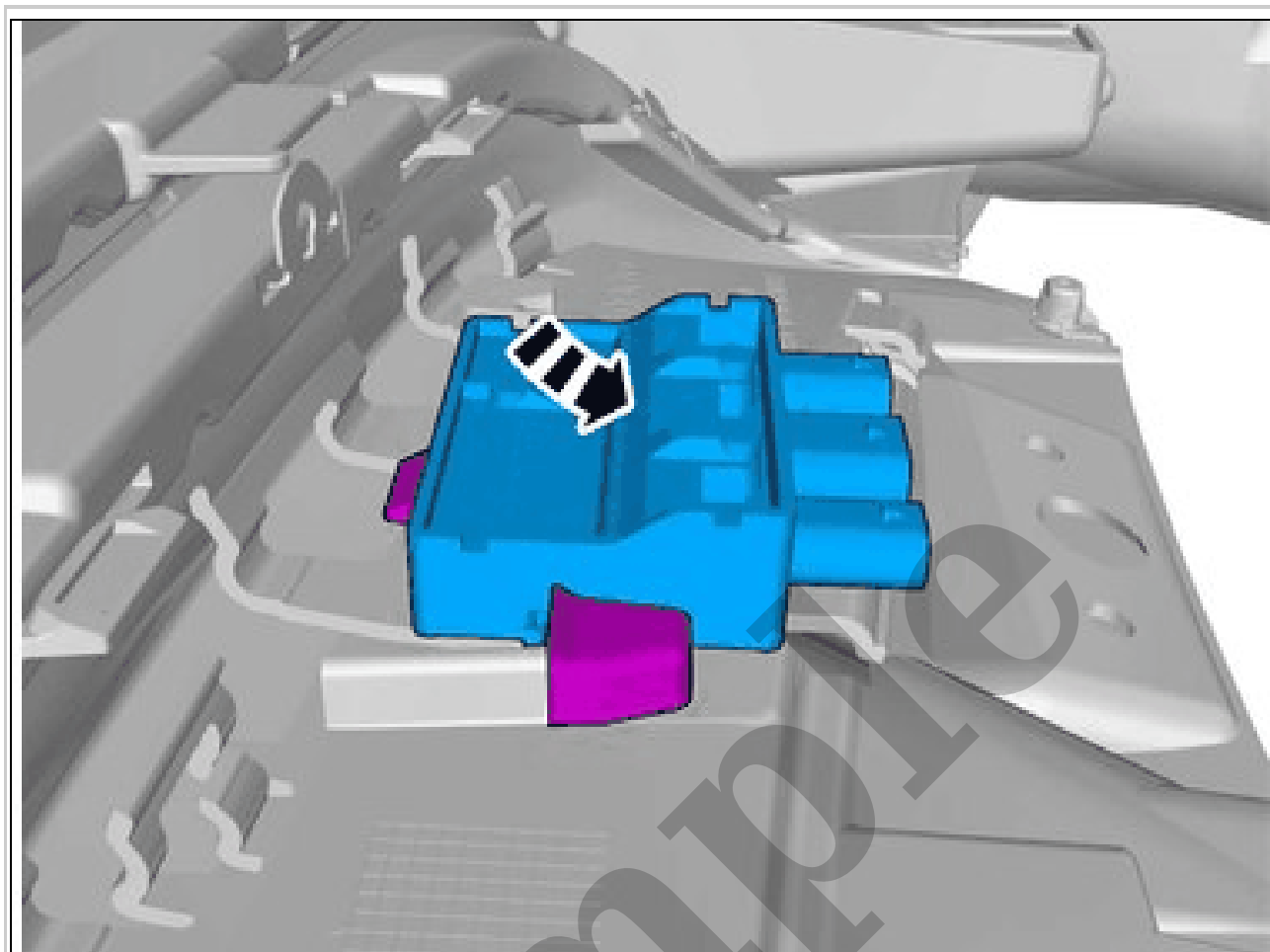

Courtesy of VOLVO CARS CORPORATION

Reinstall the removed part.

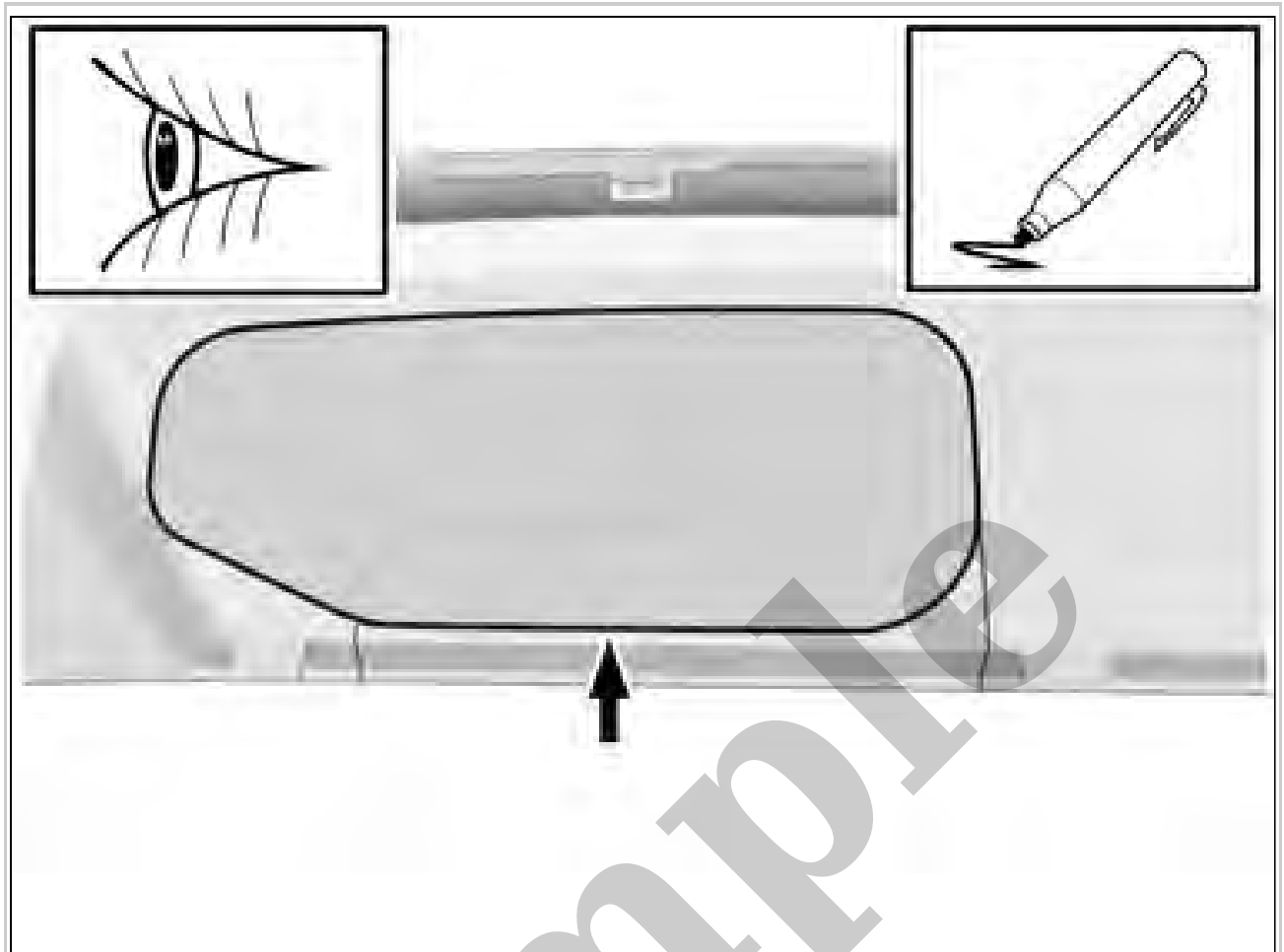

Courtesy of VOLVO CARS CORPORATION

Locate relevant marking.
Mark using a pen

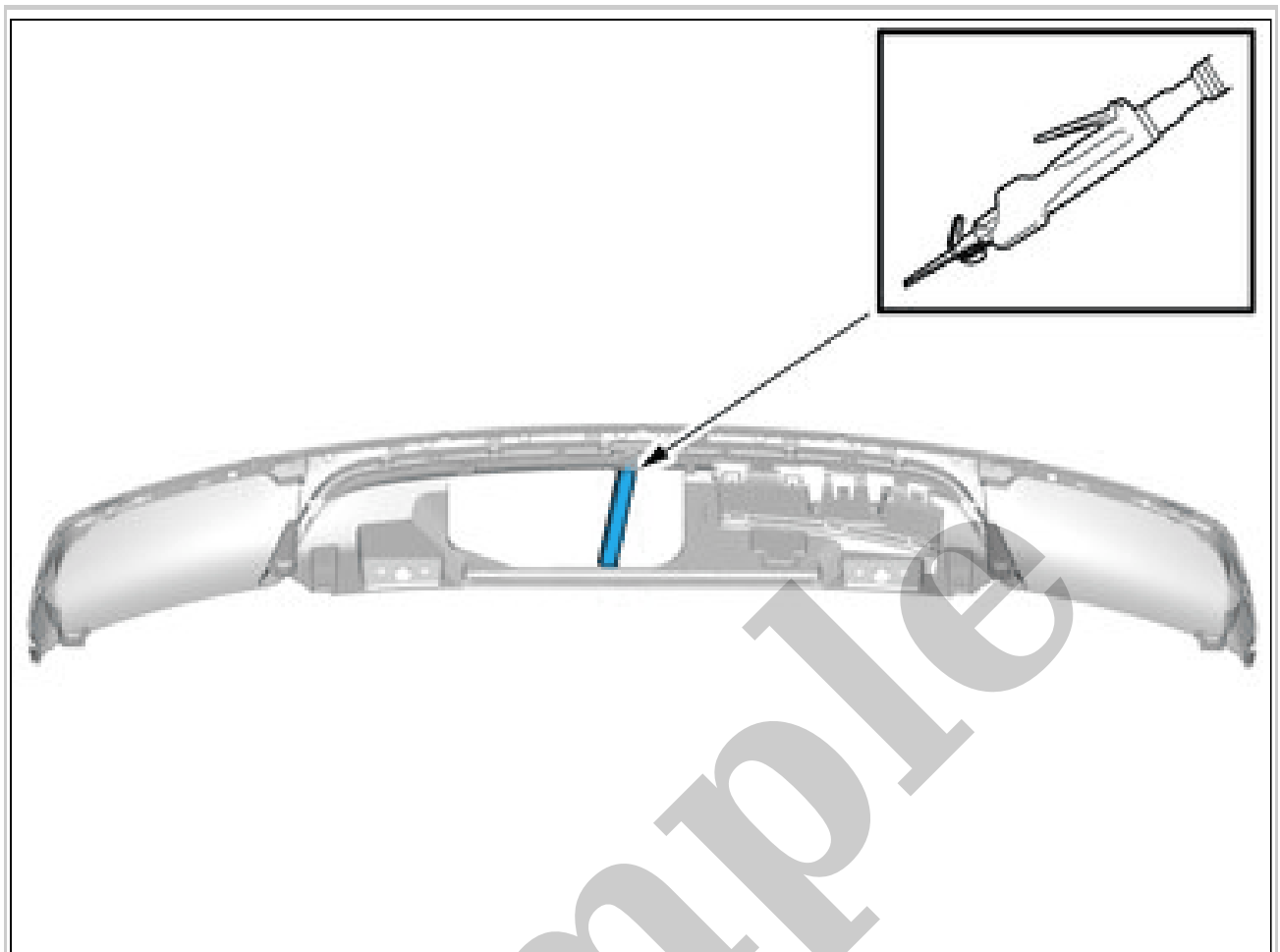

Courtesy of VOLVO CARS CORPORATION

Remove the marked part.

Use: Air-powered air saw

VEHICLES WITH TOWBAR, HITCH



Courtesy of VOLVO CARS CORPORATION

Deburr edges

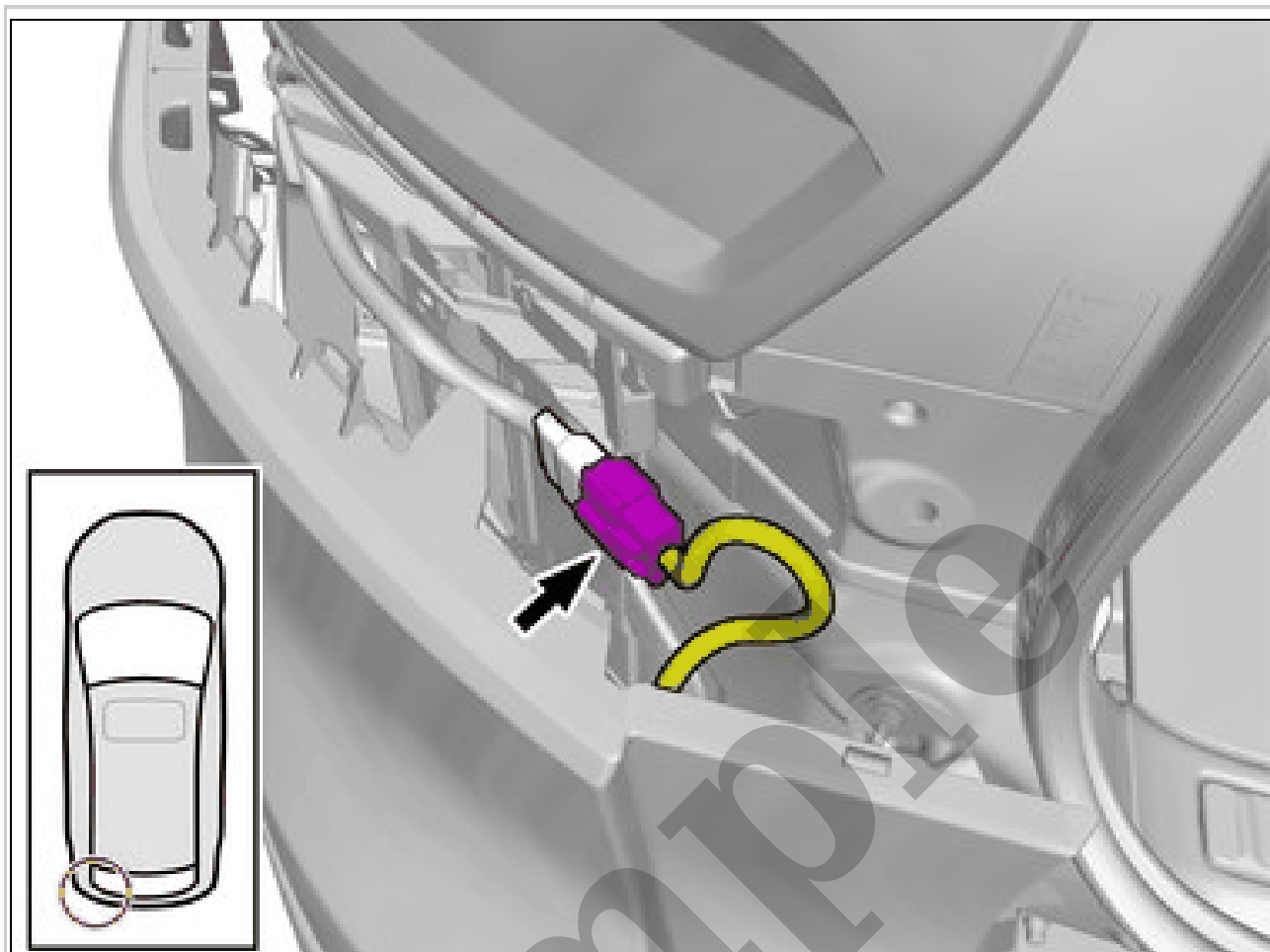

Courtesy of VOLVO CARS CORPORATION

NOTE: Orientation view

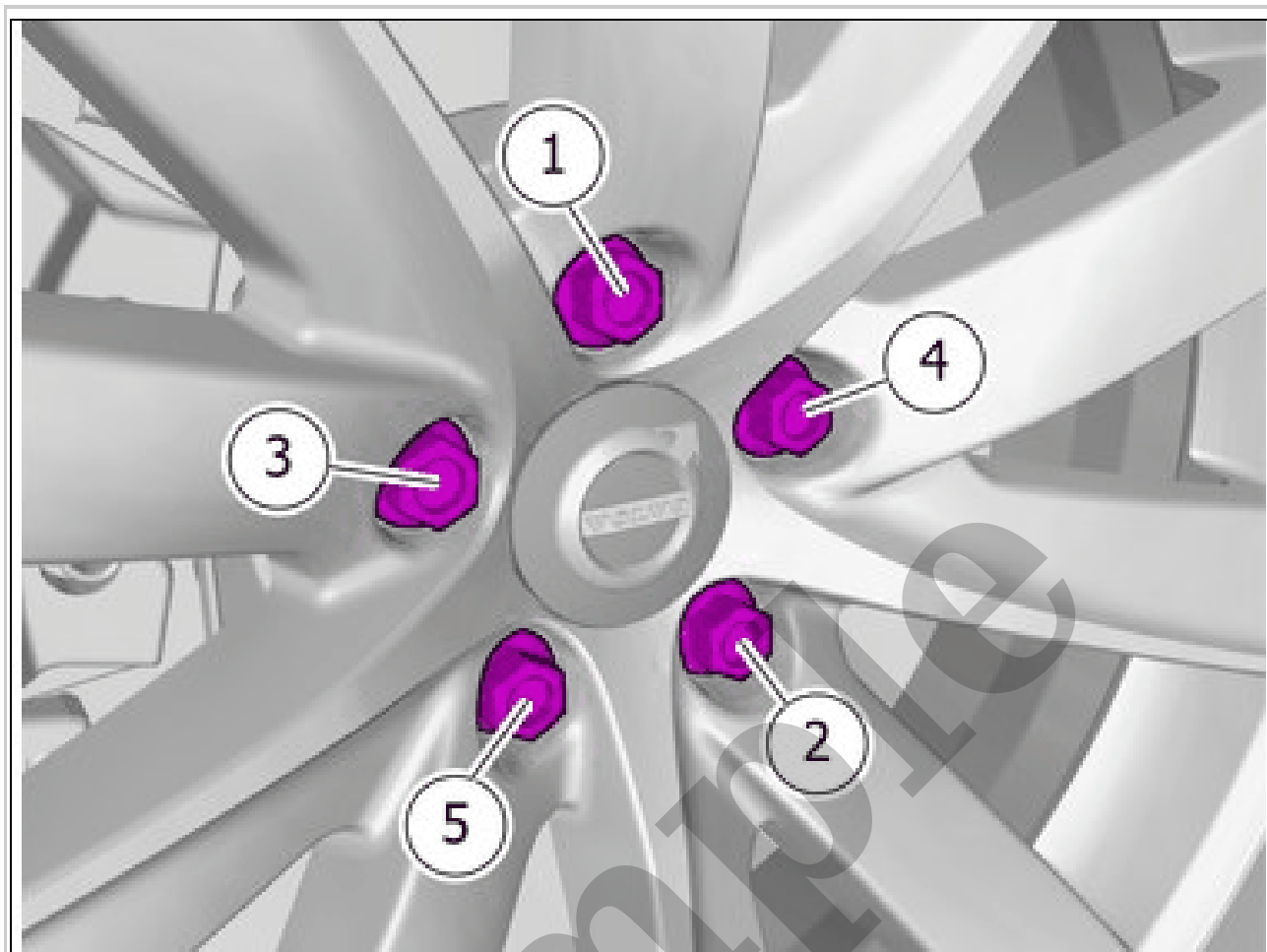

Courtesy of VOLVO CARS CORPORATION

Torque: Aluminum wheel rim to wheel hub

- Stage 1: 4Nm
- Stage 2: 50Nm
- Stage 3: 140Nm

**SKID PLATE KIT > SKID PLATE KIT (VEHICLES WITHOUT INTEGRATED END PIPES)
[2018-2020] > ACCESSORY INSTALLATION**

Equipment