

Your Ultimate Source for OEM Repair Manuals

FactoryManuals.net is a great resource for anyone who wants to save money on repairs by doing their own work. The manuals provide detailed instructions and diagrams that make it easy to understand how to fix a vehicle.

2015 FORD Ranger Super Cab OEM Service and Repair Workshop Manual

[Go to manual page](#)

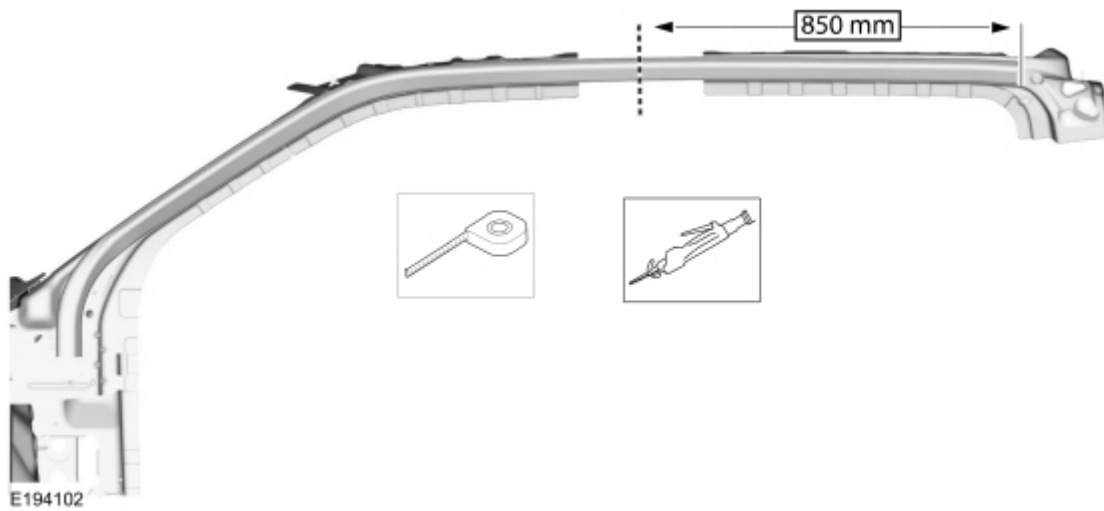

[Click here to learn about symbols, color coding, and icons used in this manual.](#)

27. Remove the roof side rail section.



[Click here to learn about symbols, color coding, and icons used in this manual.](#)

Installation

NOTE

SPR (self-piercing rivet) fasteners may not be placed directly over original SPR (self-piercing rivet) location. They must be placed adjacent to original location matching original quantity.

NOTE

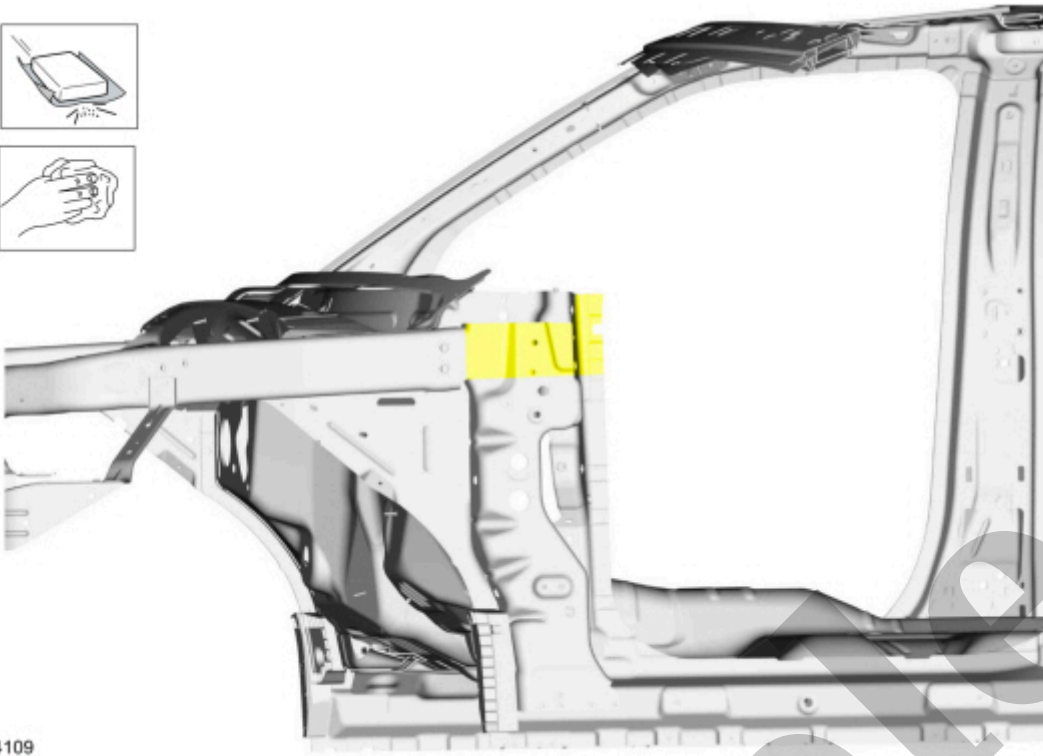

E194109

[Click here to learn about symbols, color coding, and icons used in this manual.](#)

3. NOTE

Measurement taken along the top of the side rail tube.

Carefully measure and cut the roof side rail tube service part as indicated.

Use the General Equipment: Air Body Saw

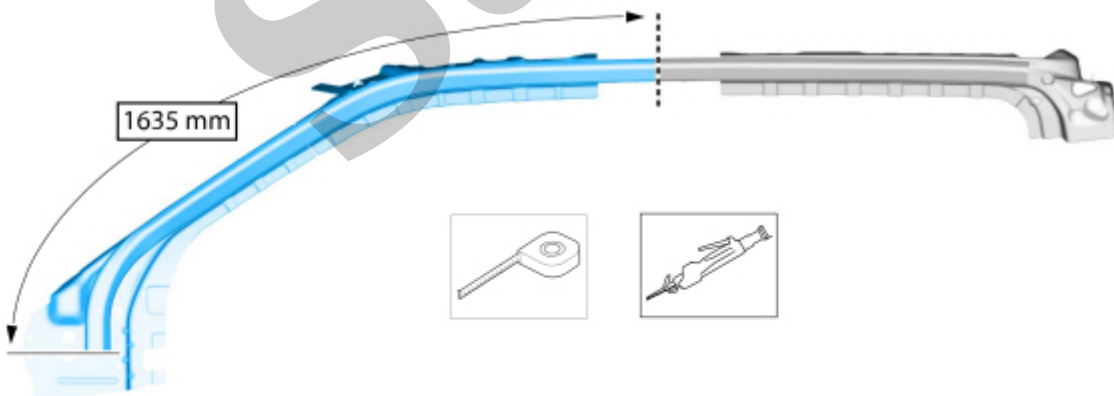

E194105

[Click here to learn about symbols, color coding, and icons used in this manual.](#)



E194106

[Click here to learn about symbols, color coding, and icons used in this manual.](#)

7. Apply adhesive.

Material : Metal Bonding Adhesive / TA-1, TA-1-B, 3M™ 08115, LORD Fusor® 108B, Henkel Teroson EP 5055

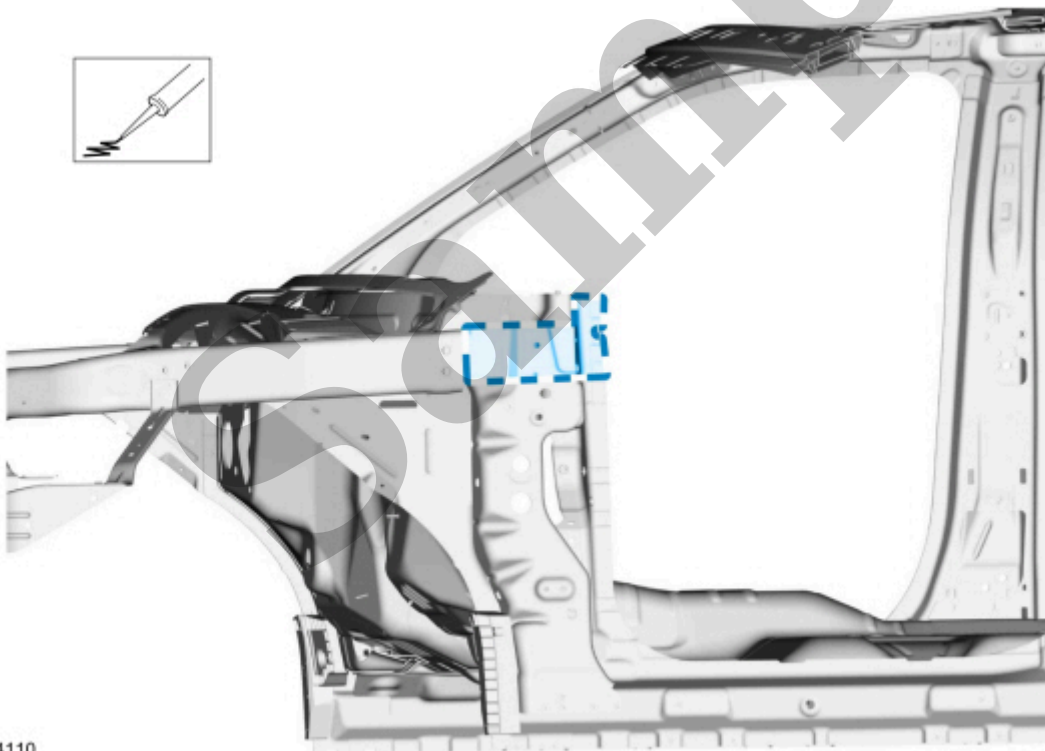

E194110

[Click here to learn about symbols, color coding, and icons used in this manual.](#)

8. **NOTE**



[Click here to learn about symbols, color coding, and icons used in this manual.](#)

10. Weld as indicated.

- Install MIG (metal inert gas) plug welds.

Use the General Equipment: MIG/MAG Welding Equipment

- Entirely seam weld as indicated.

Use the General Equipment: MIG/MAG Welding Equipment

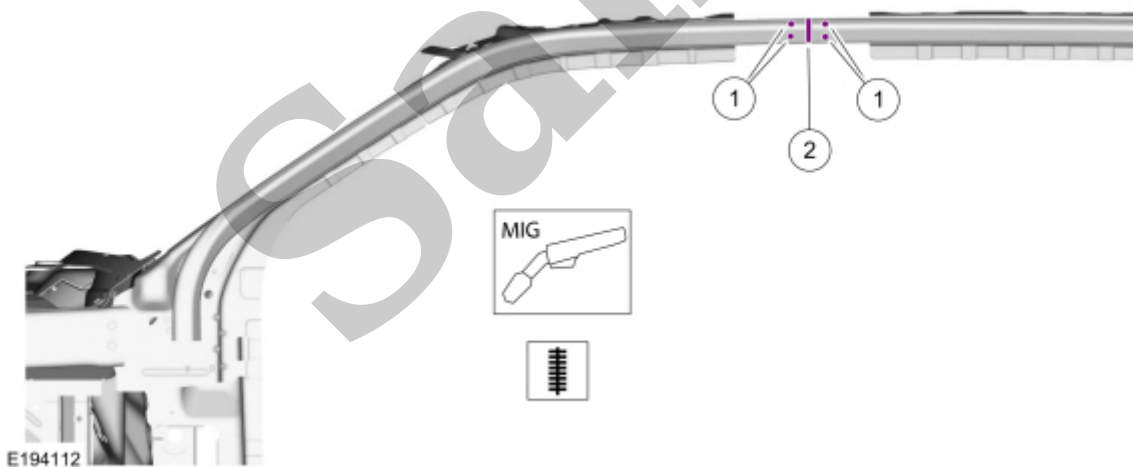

[Click here to learn about symbols, color coding, and icons used in this manual.](#)

11. Metal finish as required using typical metal finishing techniques.

12. Install, clamp and drill side rail to B-pillar gusset as indicated.

Use the General Equipment: Locking Pliers

Refer to: [Joining Techniques](#)(501-25 Body Repairs - General Information, General Procedures).

Use the General Equipment: Blind Rivet Gun

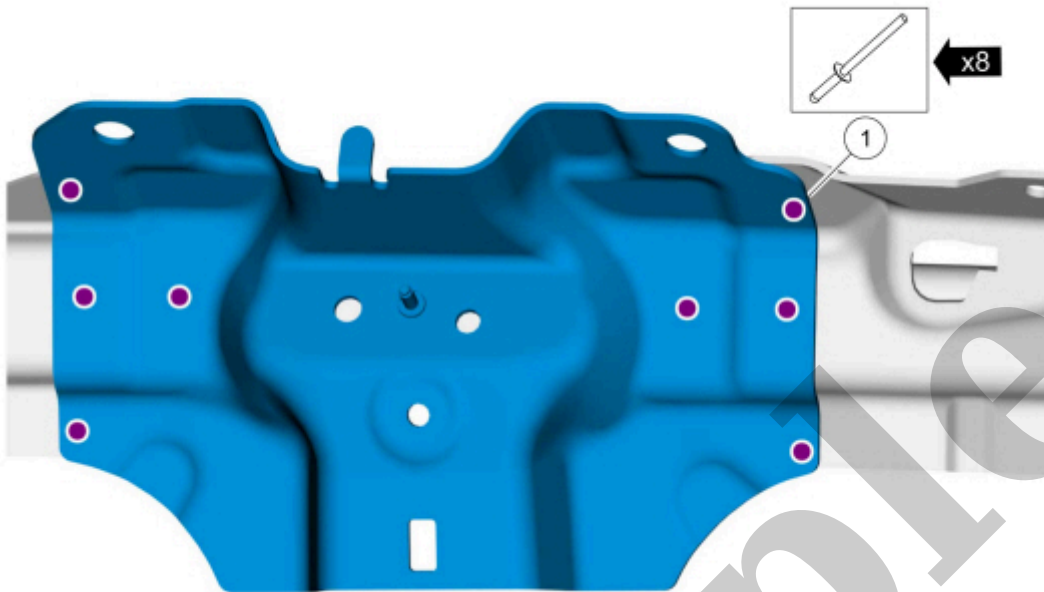

E194114

[Click here to learn about symbols, color coding, and icons used in this manual.](#)

14. Position the B-pillar inner panel, clamp and drill 6.5mm holes as indicated.

Use the General Equipment: Locking Pliers

Use the General Equipment: 6.5 mm Drill Bit

				0401			
2	-	-	-	-	W708777-S900C	-	-

Refer to: [Joining Techniques](#)(501-25 Body Repairs - General Information, General Procedures).

Use the General Equipment: Self-Piercing Rivet (SPR) Remover/Installer

Use the General Equipment: Blind Rivet Gun



[Click here to learn about symbols, color coding, and icons used in this manual.](#)

16. Install the body side panel. Metal finish using typical metal finishing techniques.

Refer to: [Body Panel Sectioning](#)(501-26 Body Repairs - Vehicle Specific Information and Tolerance Checks, General Procedures).

Refer to: [Joining Techniques](#)(501-25 Body Repairs - General Information, General Procedures).

17. Position the roof reinforcement assembly, clamp and drill 6.5mm holes as indicated.

Use the General Equipment: Locking Pliers

Use the General Equipment: 6.5 mm Drill Bit

2	W717338-S900	EM	DP11- 225/H	-	-	-	-
---	--------------	----	-------------	---	---	---	---

Refer to: [Joining Techniques](#)(501-25 Body Repairs - General Information, General Procedures).

Use the General Equipment: Blind Rivet Gun

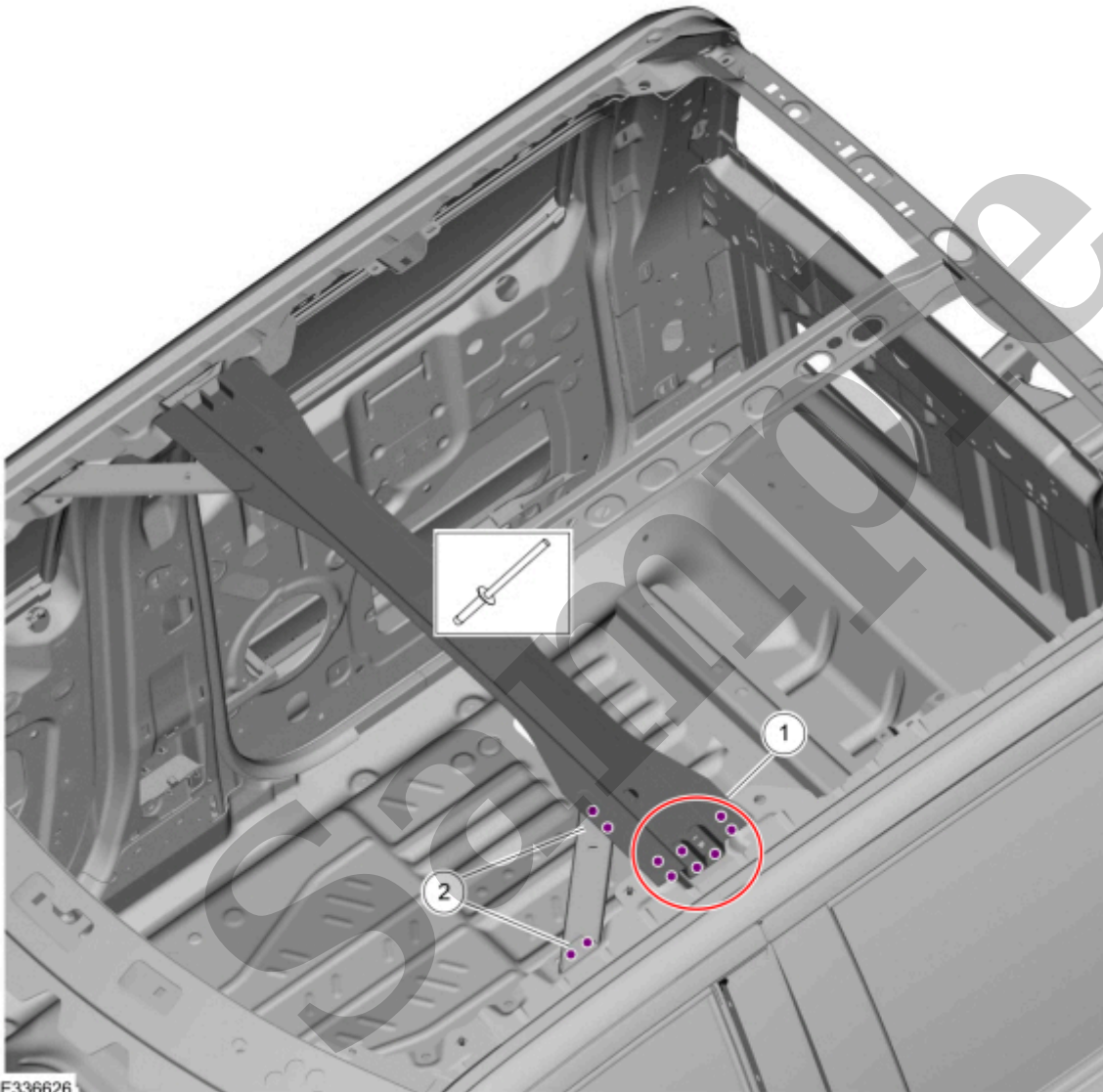

[Click here to learn about symbols, color coding, and icons used in this manual.](#)

19. Position the windshield header panel, clamp and drill 6.5mm holes as indicated.

Use the General Equipment: Locking Pliers

Use the General Equipment: 6.5 mm Drill Bit

2	W710246-S900	BN	DP10-200/H	SA-0400/SA-0402	-	W790377-S900	-
---	--------------	----	------------	-----------------	---	--------------	---

Refer to: [Joining Techniques](#)(501-25 Body Repairs - General Information, General Procedures).

Use the General Equipment: Self-Piercing Rivet (SPR) Remover/Installer

Use the General Equipment: Blind Rivet Gun

Use the General Equipment: Blind Rivet Gun

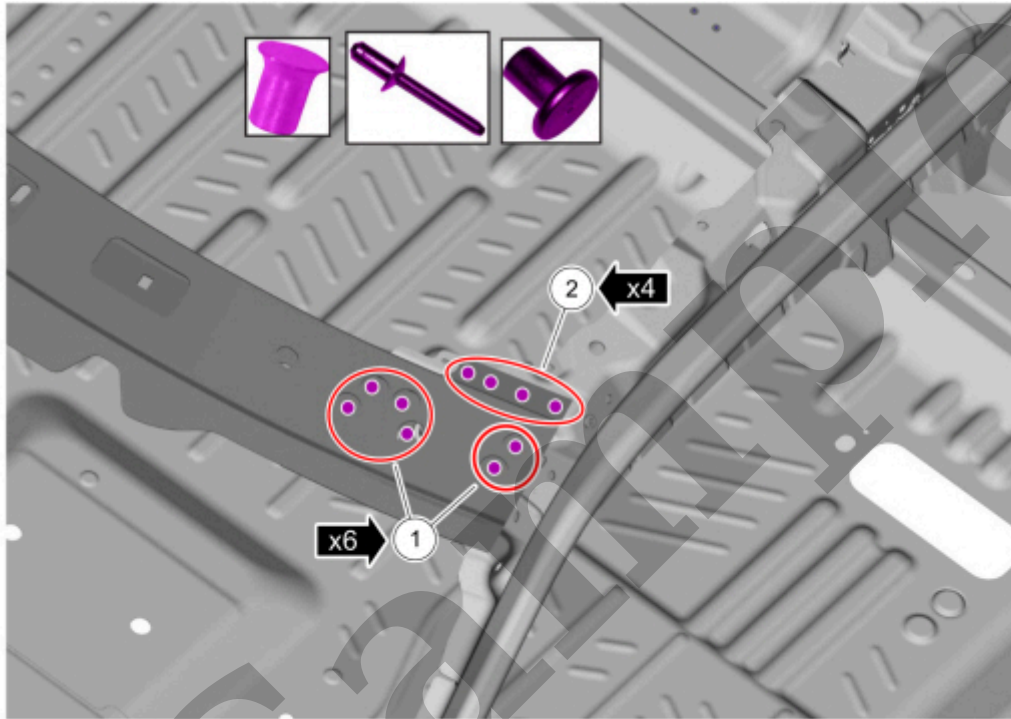

E192615

[Click here to learn about symbols, color coding, and icons used in this manual.](#)

21. Drill the five 6.5mm holes as indicated.

Use the General Equipment: 6.5 mm Drill Bit

2	-	-	-	-	W708777- S900C	-	-
---	---	---	---	---	-------------------	---	---

Refer to: [Joining Techniques](#)(501-25 Body Repairs - General Information, General Procedures).

Use the General Equipment: Blind Rivet Gun

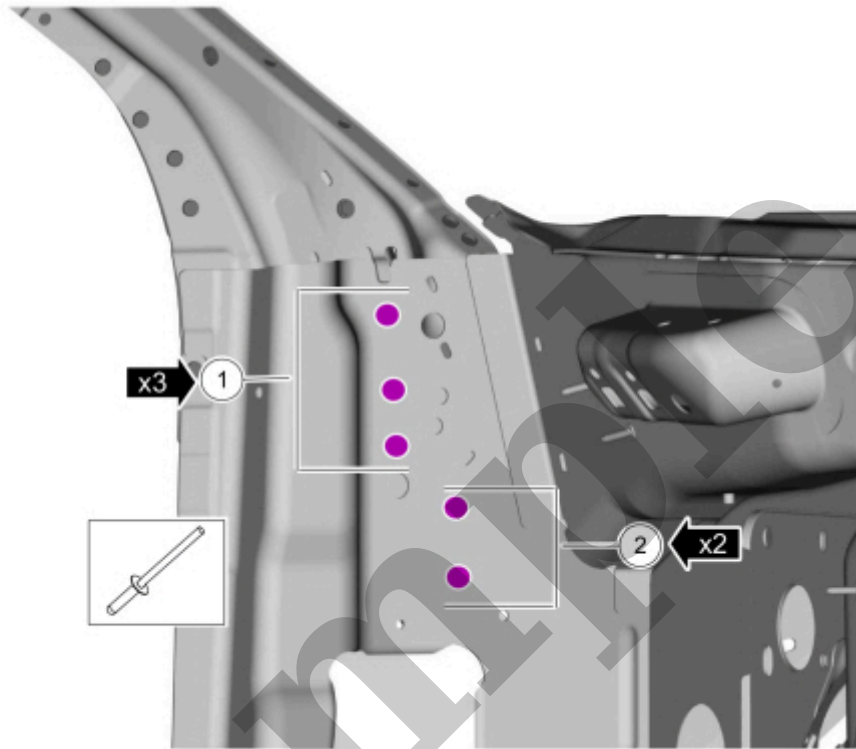

E192617

[Click here to learn about symbols, color coding, and icons used in this manual.](#)

23. Install the cross-car beam bracket and the bolts.

Torque : 18 lb.ft (25 Nm)