

Your Ultimate Source for OEM Repair Manuals

FactoryManuals.net is a great resource for anyone who wants to save money on repairs by doing their own work. The manuals provide detailed instructions and diagrams that make it easy to understand how to fix a vehicle.

2014 VOLVO V40 Cross Country OEM Service and Repair Workshop Manual

[Go to manual page](#)

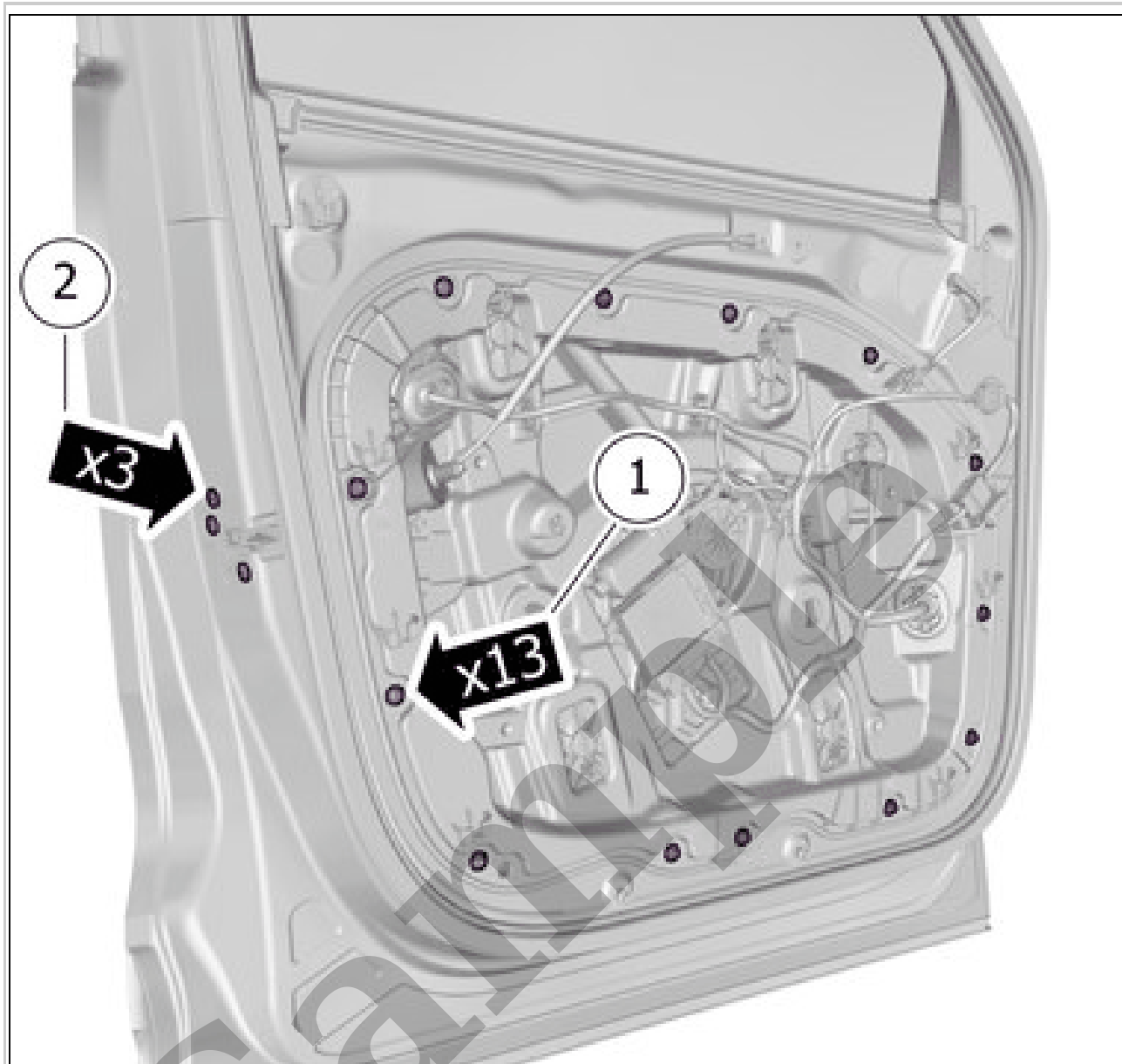

Courtesy of VOLVO CARS CORPORATION

Remove the screws.

1. **Torque:** M5, 5Nm

2. **Torque:** M6, 10Nm

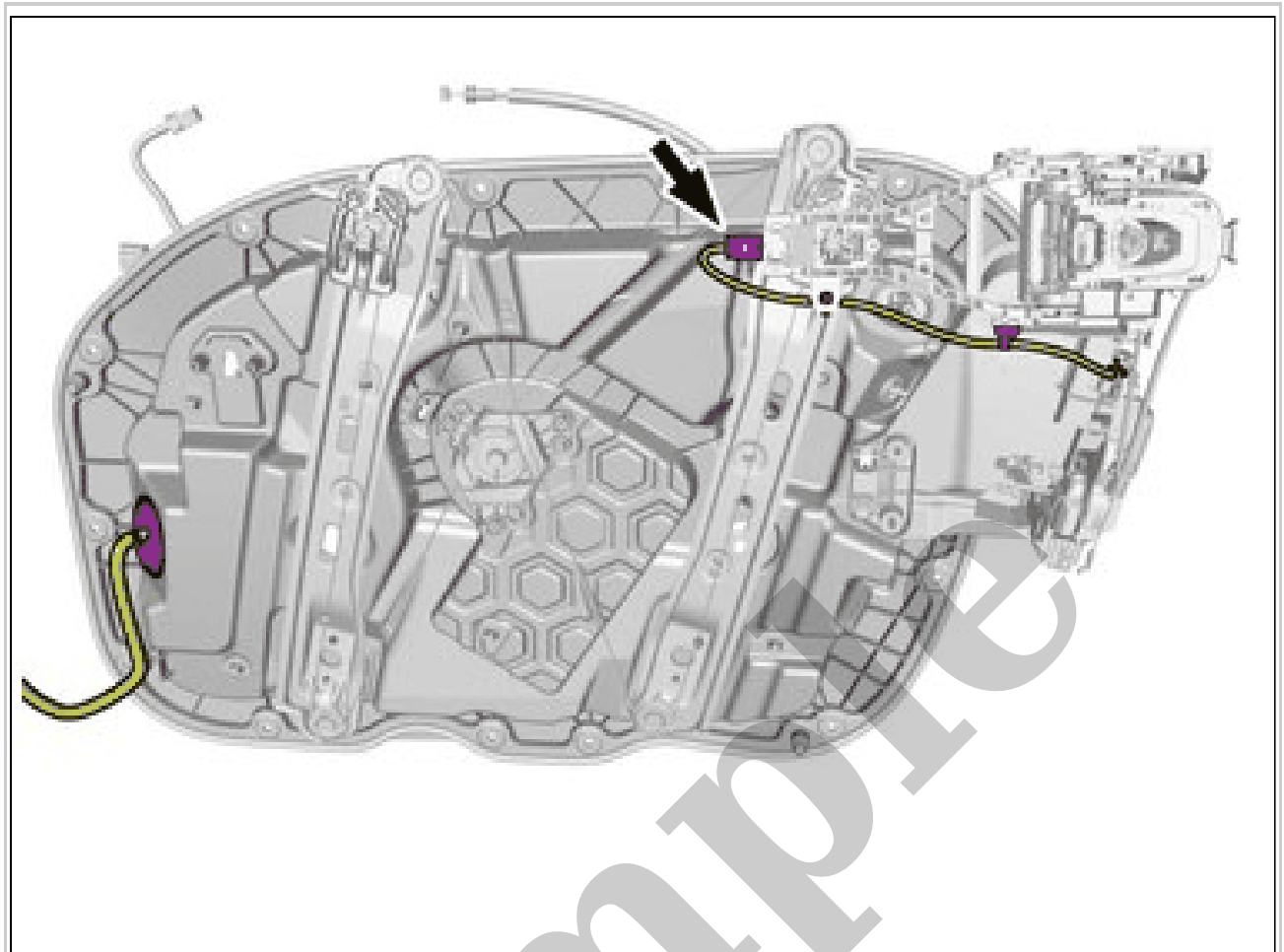

Courtesy of VOLVO CARS CORPORATION

The graphic shows the back of the component.
Disconnect the connector.
Remove the cable harness clips.

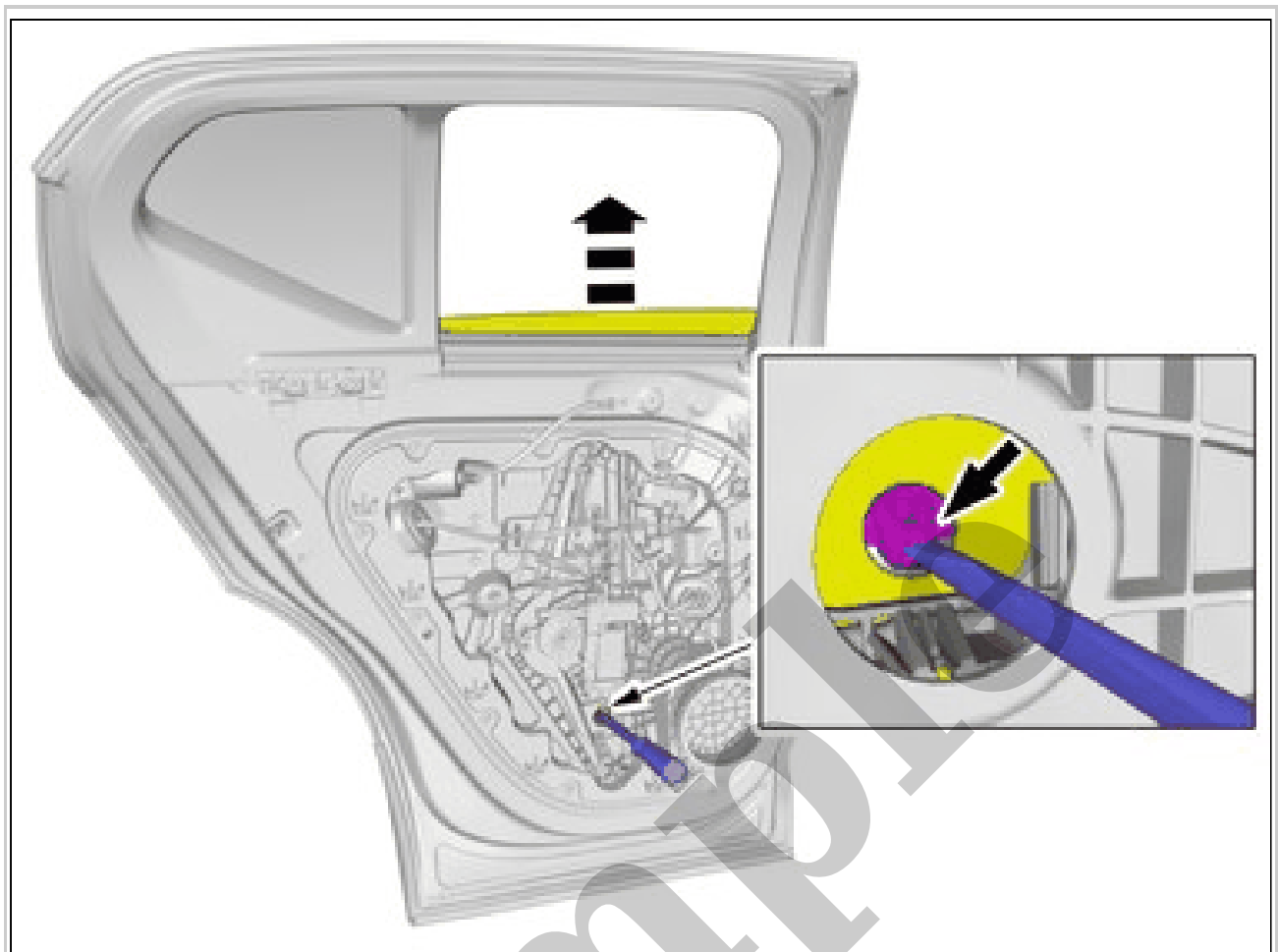

Courtesy of VOLVO CARS CORPORATION

HINT: This step may require the aid of another technician.

Release the lock.

Lift the marked component up

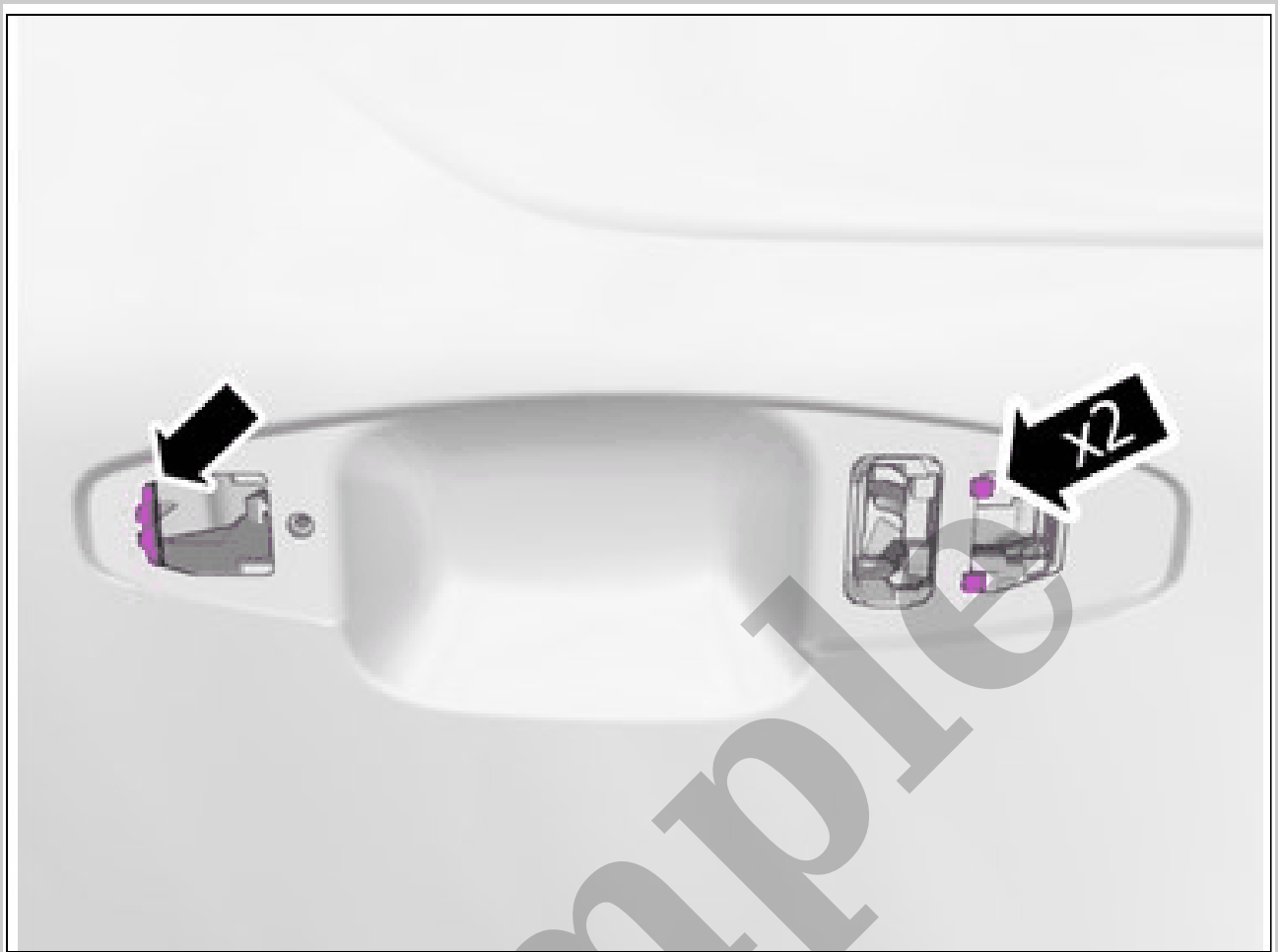

Courtesy of VOLVO CARS CORPORATION

Release the catches.

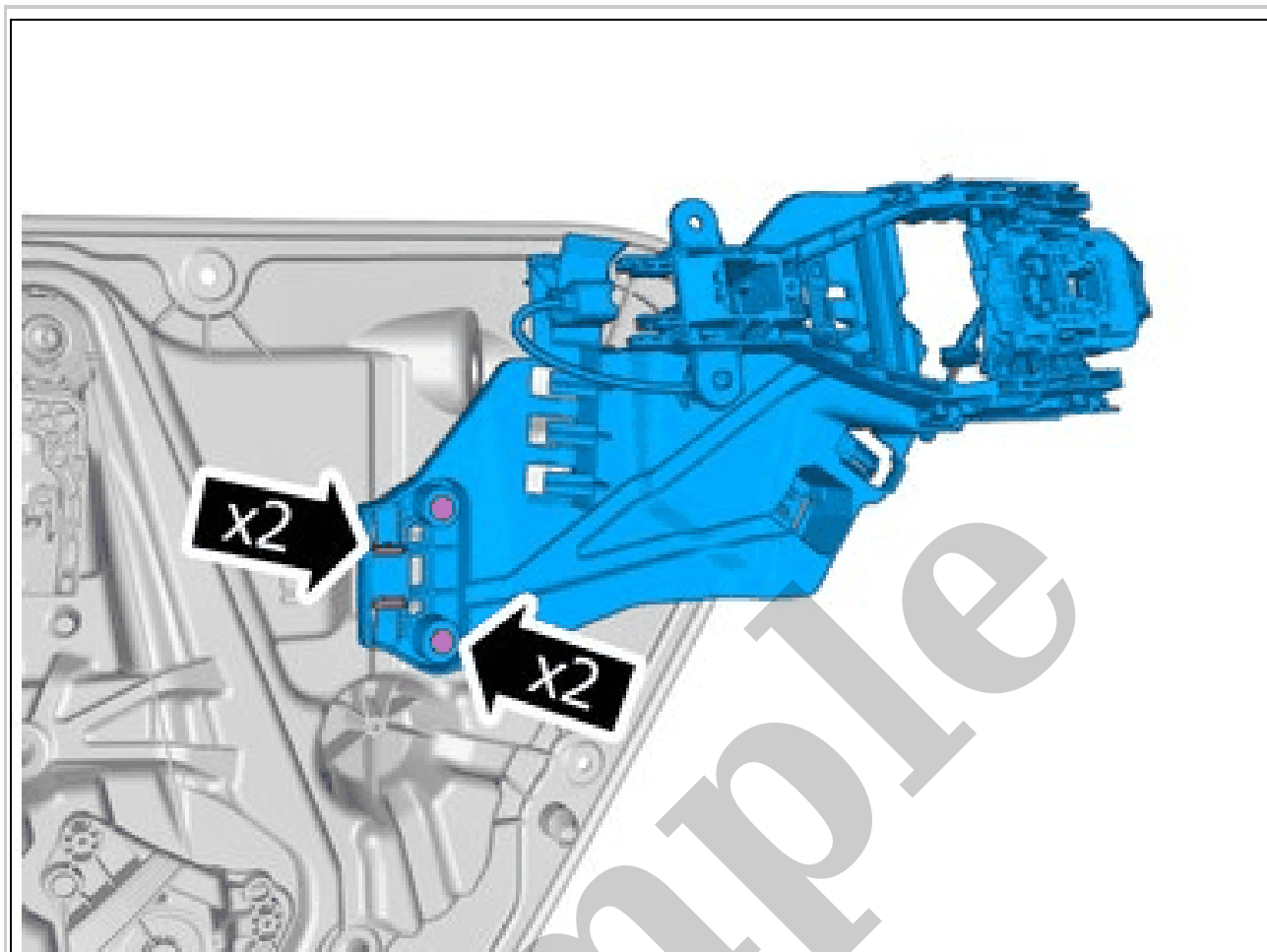

Courtesy of VOLVO CARS CORPORATION

Remove the screws.
Remove the part carefully

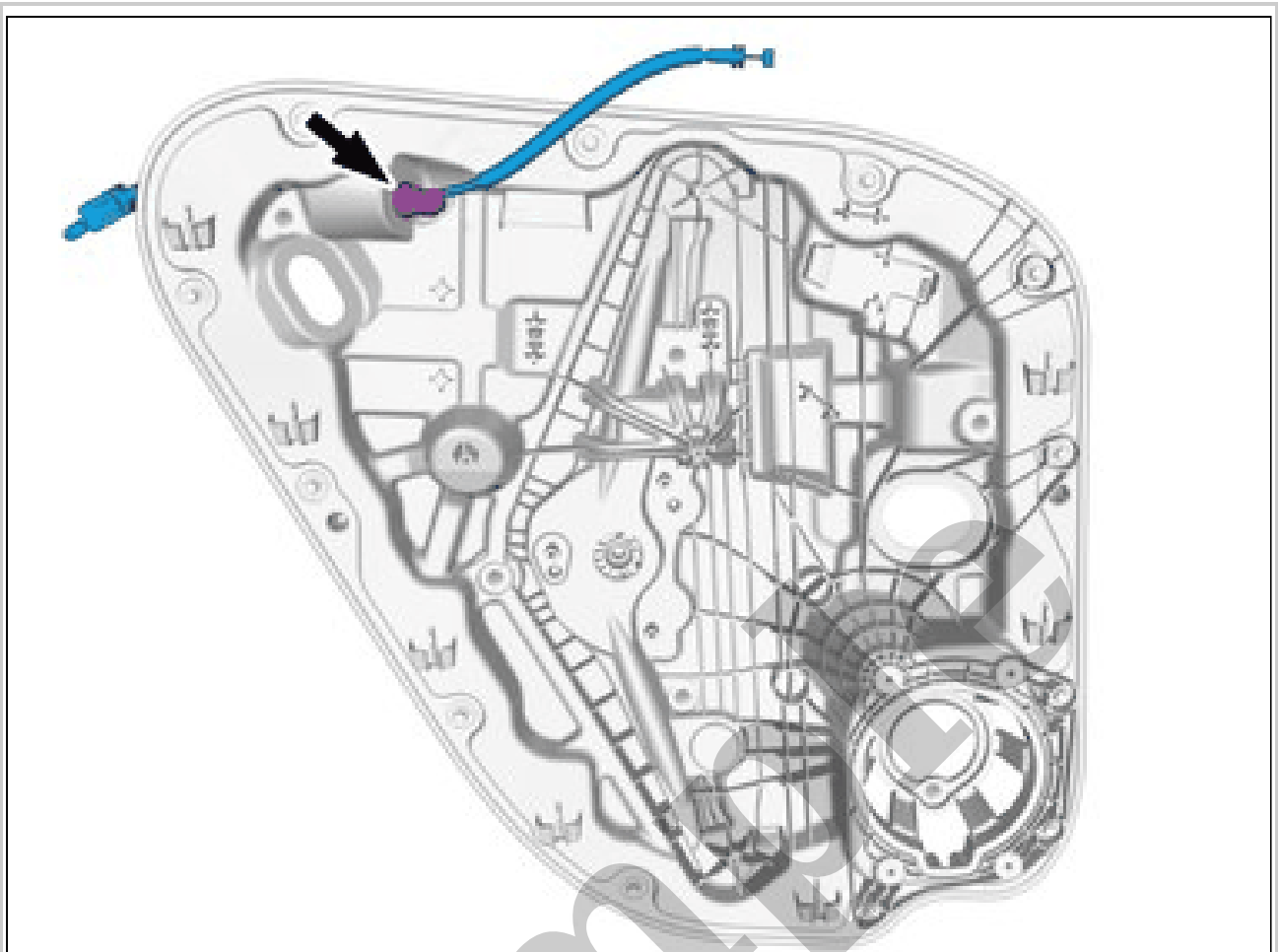

Courtesy of VOLVO CARS CORPORATION

Remove the marked part.

INSTALLATION

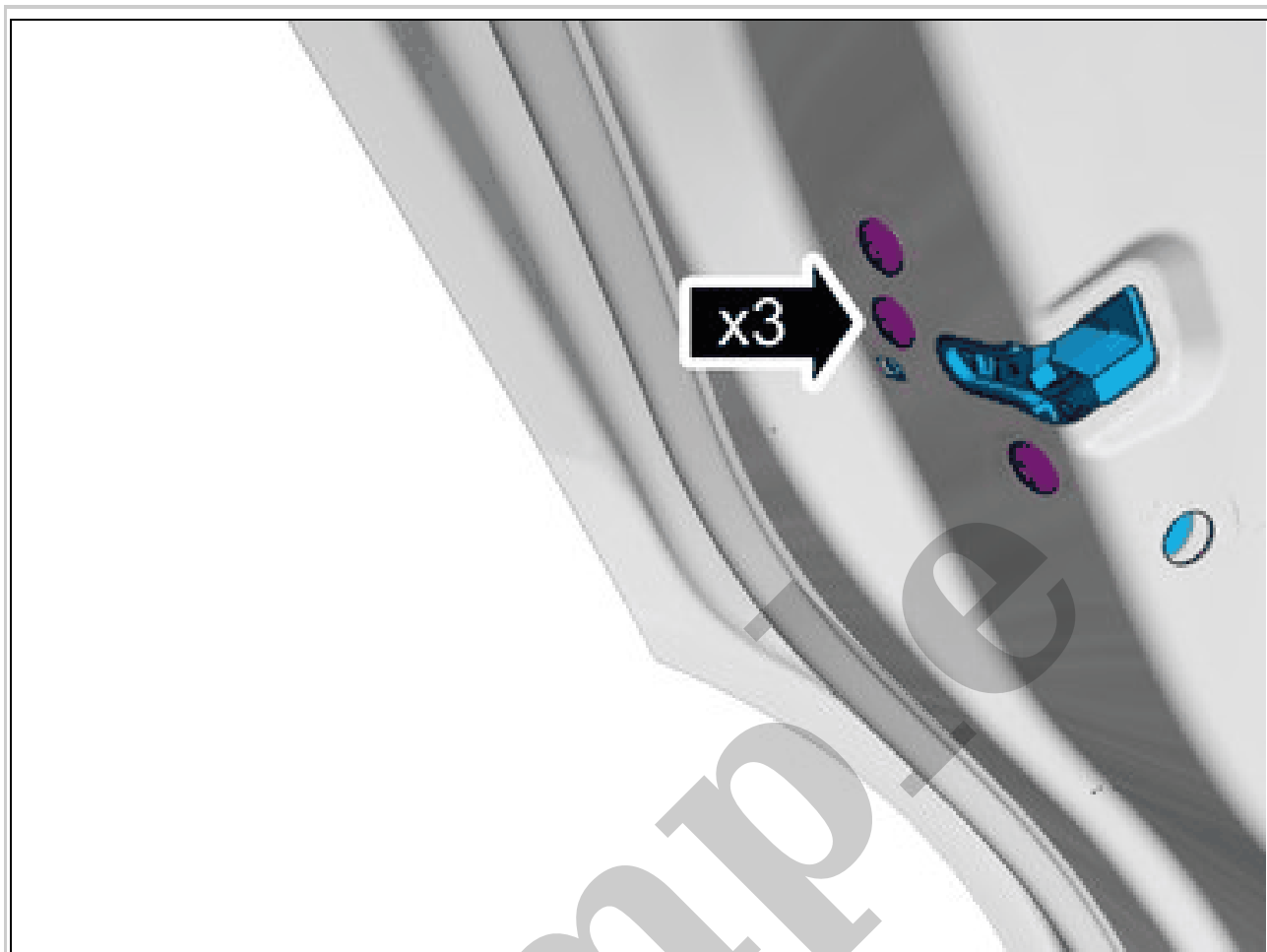

Courtesy of VOLVO CARS CORPORATION

Install the screws.

Torque: M6, 10Nm

To install, reverse the removal procedure.

Perform power window motor, initiation. Refer to: DOOR WINDOW MOTOR INITIALIZATION

**APRON MOLDING SUNROOF > APRON MOLDING SUNROOF [2018-2022] >
REMOVAL AND INSTALLATION**



Courtesy of VOLVO CARS CORPORATION

Remove the marked part.

Sample

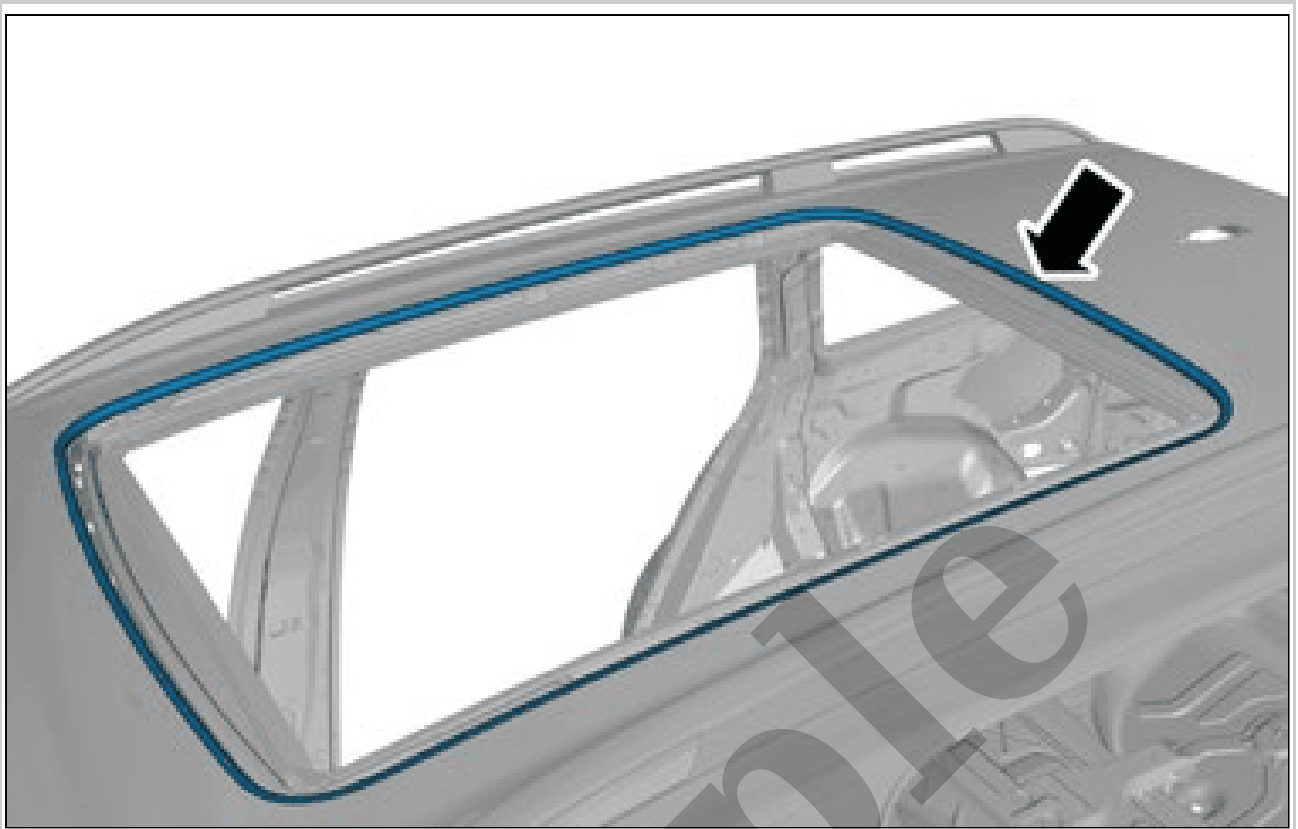

Courtesy of VOLVO CARS CORPORATION

CAUTION: *The component must be removed by hand.
Tools may not be used.*

Follow the instructions regarding components with double-sided adhesive tape. Refer to:
COMPONENTS WITH DOUBLE-SIDED TAPE