

Your Ultimate Source for OEM Repair Manuals

FactoryManuals.net is a great resource for anyone who wants to save money on repairs by doing their own work. The manuals provide detailed instructions and diagrams that make it easy to understand how to fix a vehicle.

2014 Ford Edge Service and Repair Manual

[Go to manual page](#)

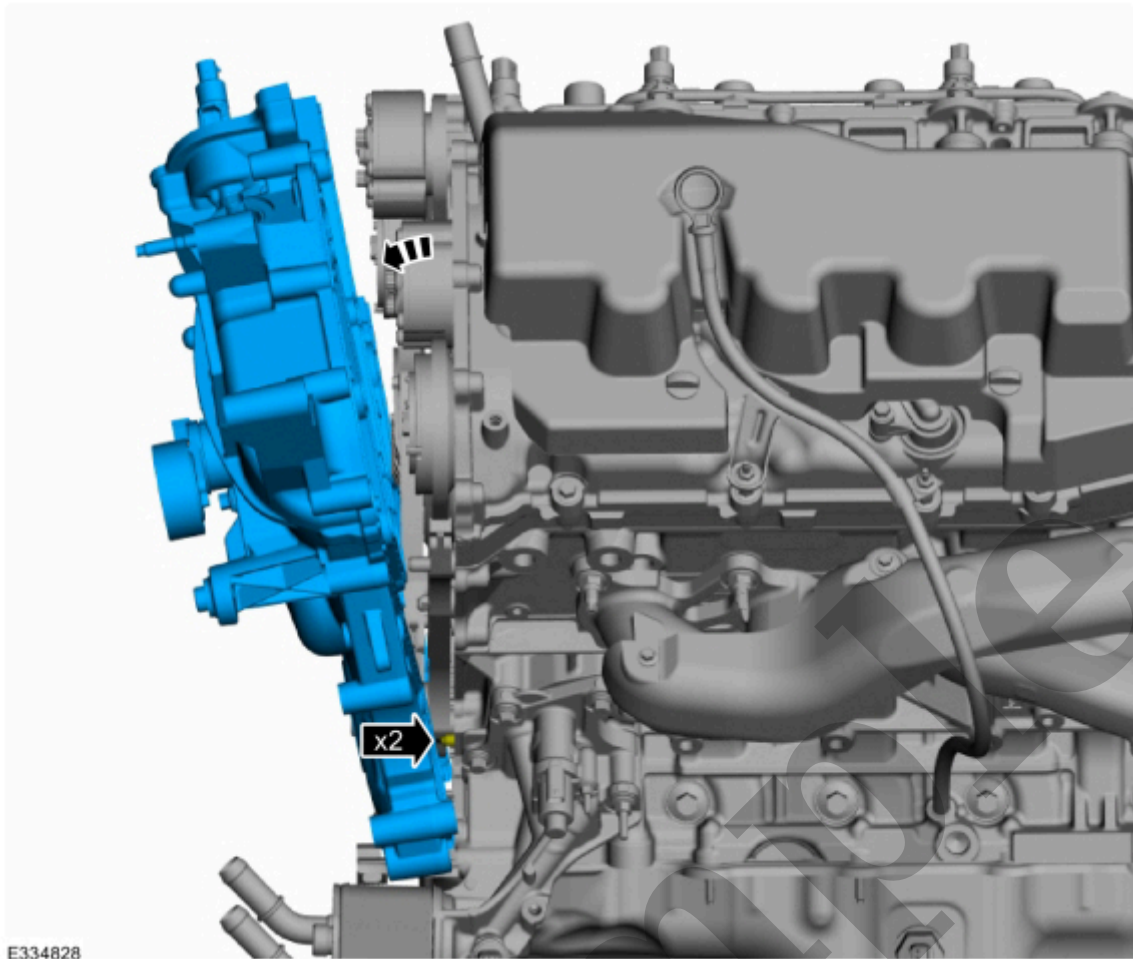

[Click here to learn about symbols, color coding, and icons used in this manual.](#)

56. Remove and discard the gaskets.

58. **NOTE**

Clean the valve cover gasket groove with soap and water or a suitable solvent.

Remove and discard the gasket.

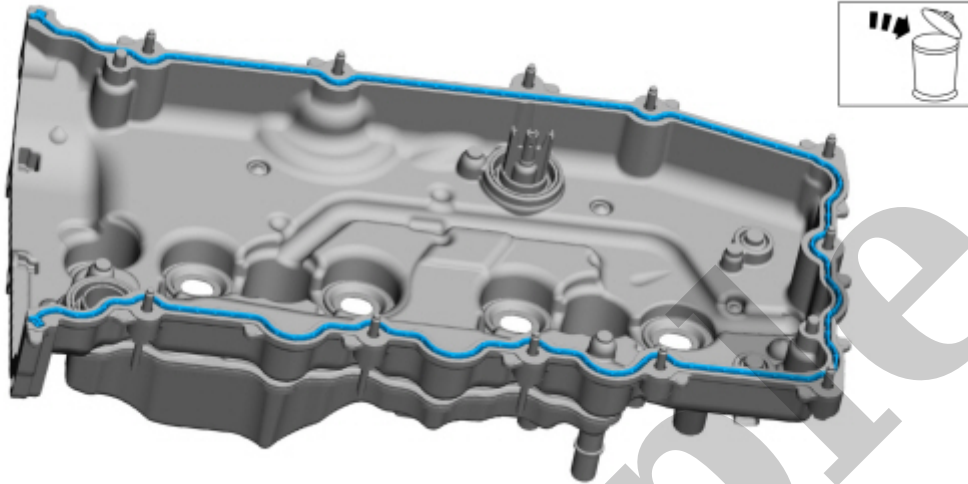

E332178

[Click here to learn about symbols, color coding, and icons used in this manual.](#)

59. If necessary, remove the bolts and the crankcase vent oil separator.

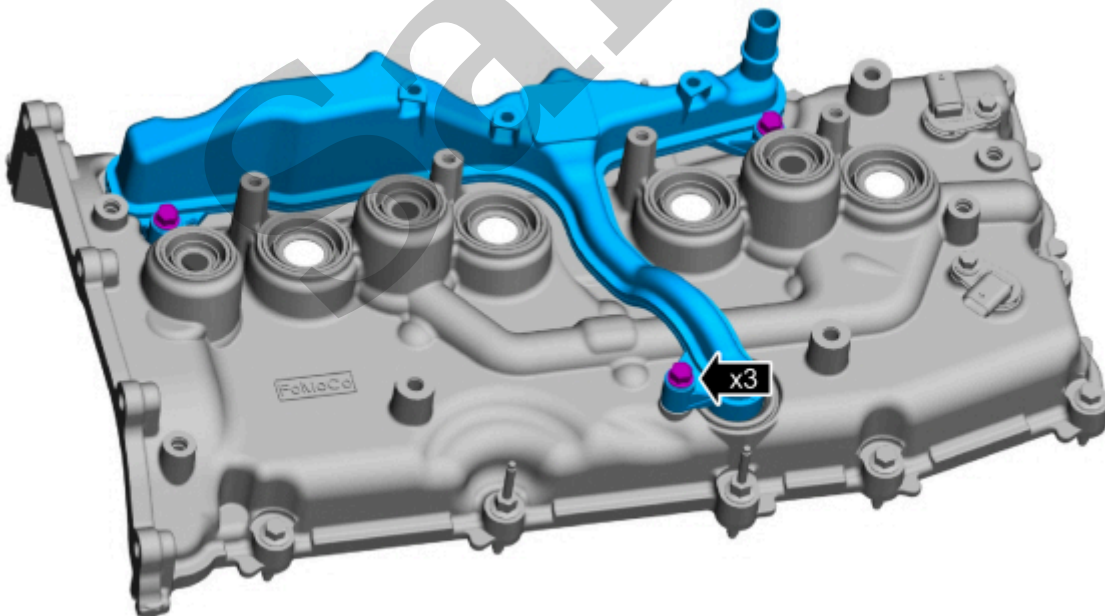

E332180

[Click here to learn about symbols, color coding, and icons used in this manual.](#)

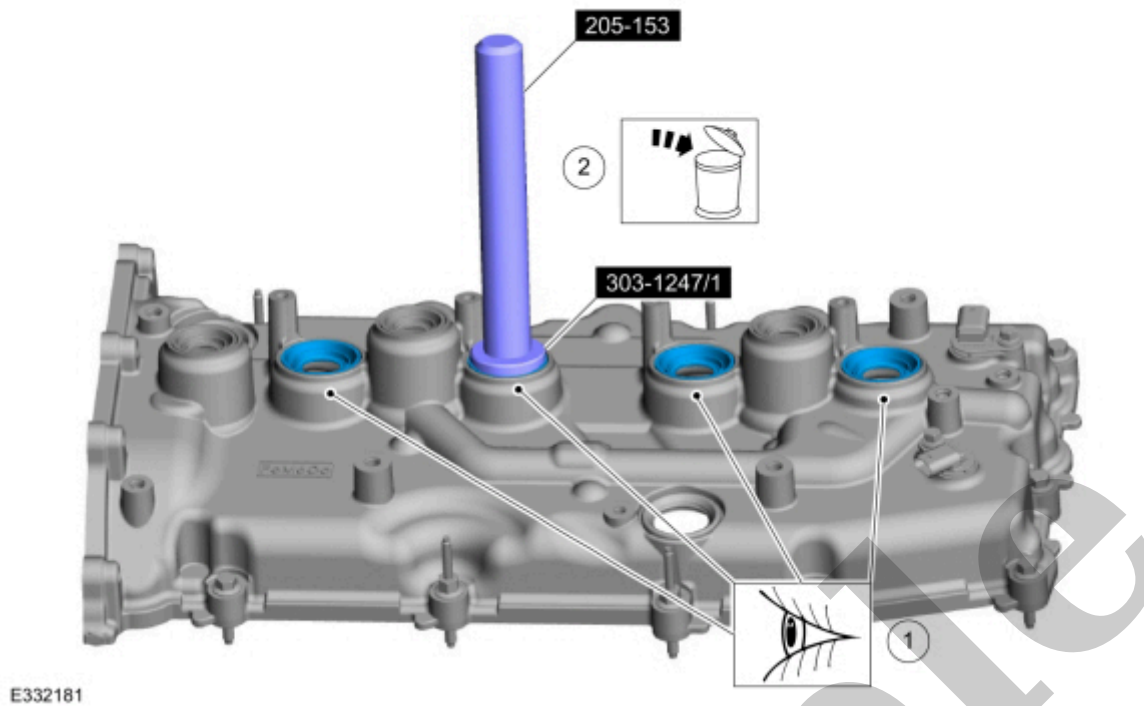

[Click here to learn about symbols, color coding, and icons used in this manual.](#)

62. 1. Inspect the VCT (variable camshaft timing) oil control solenoid seal and the cylinder deactivation solenoid seals.
2. Remove and discard any damaged seals using the special tools.

Use Special Service Tool : 205-153 (T80T-4000-W) Handle , 205-142 (T80T-4000-J) Installer, Differential Bearing Cone

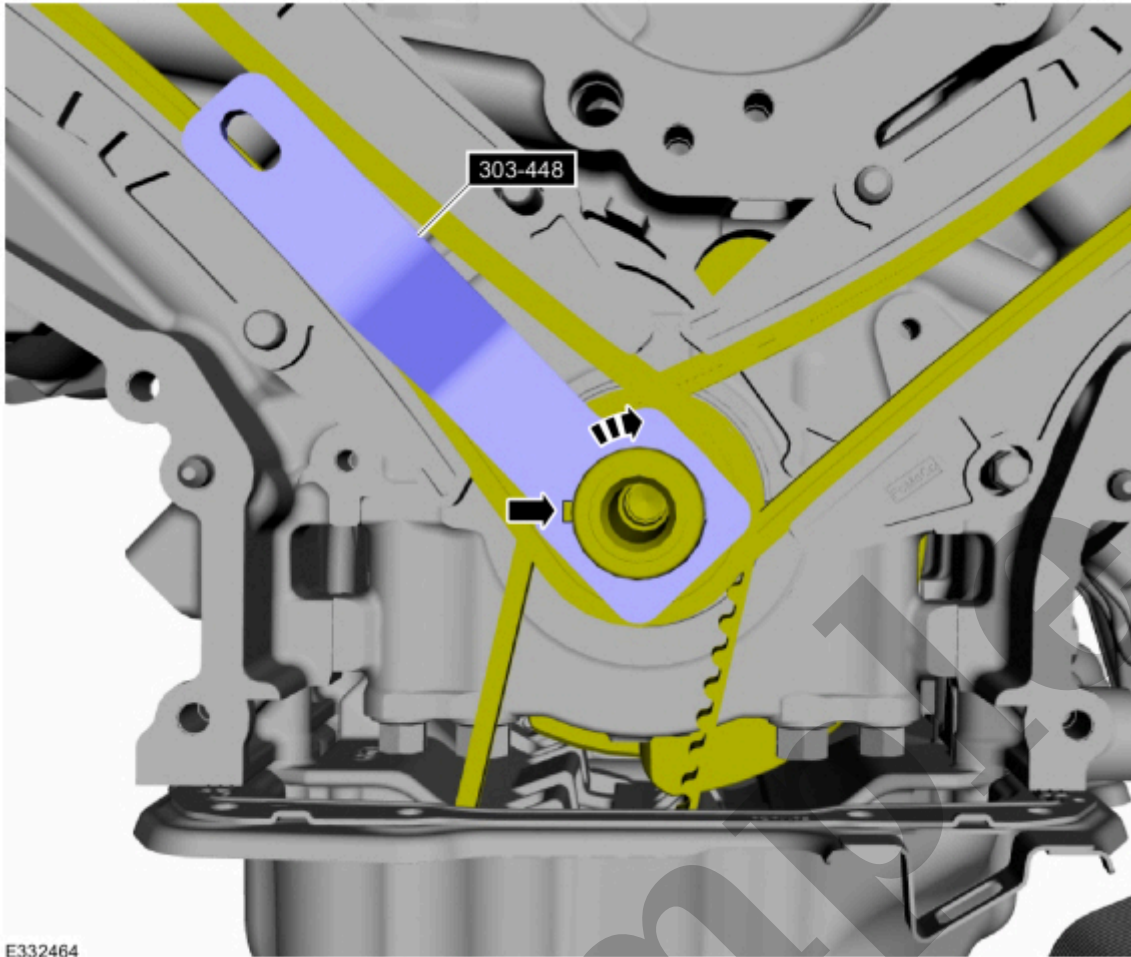

[Click here to learn about symbols, color coding, and icons used in this manual.](#)

65. Verify the timing mark on the RH (right-hand) VCT (variable camshaft timing) unit is on top, if not, rotate the crankshaft clockwise one complete revolution so the keyway is at the 9:00 position.

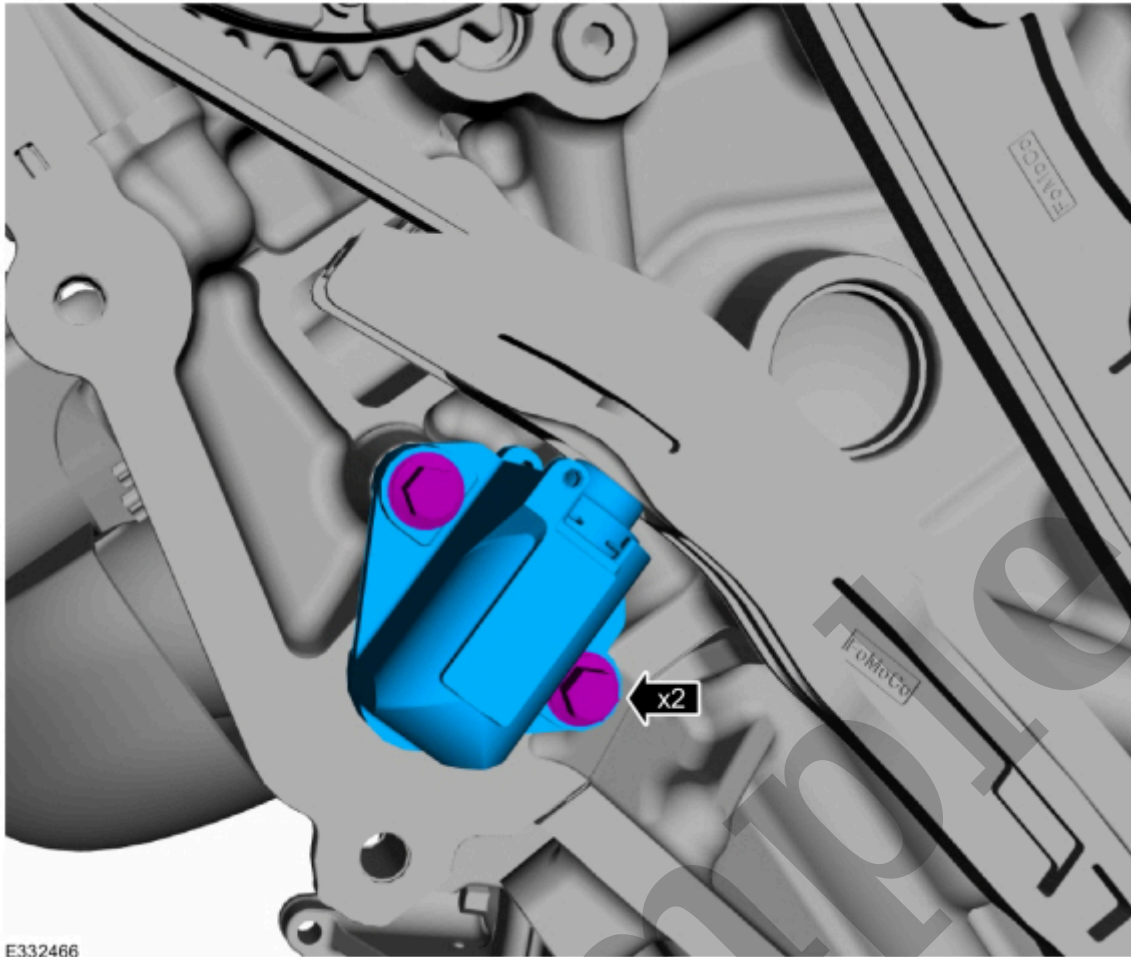

[Click here to learn about symbols, color coding, and icons used in this manual.](#)

67. **NOTE**

It may be necessary to rotate the crankshaft slightly to provide enough slack in the chain to remove the RH (right-hand) timing chain tensioner arm. Return the crankshaft keyway to the 9:00 position after removing the RH (right-hand) timing chain tensioner arm.

Remove the RH (right-hand) timing chain tensioner arm.

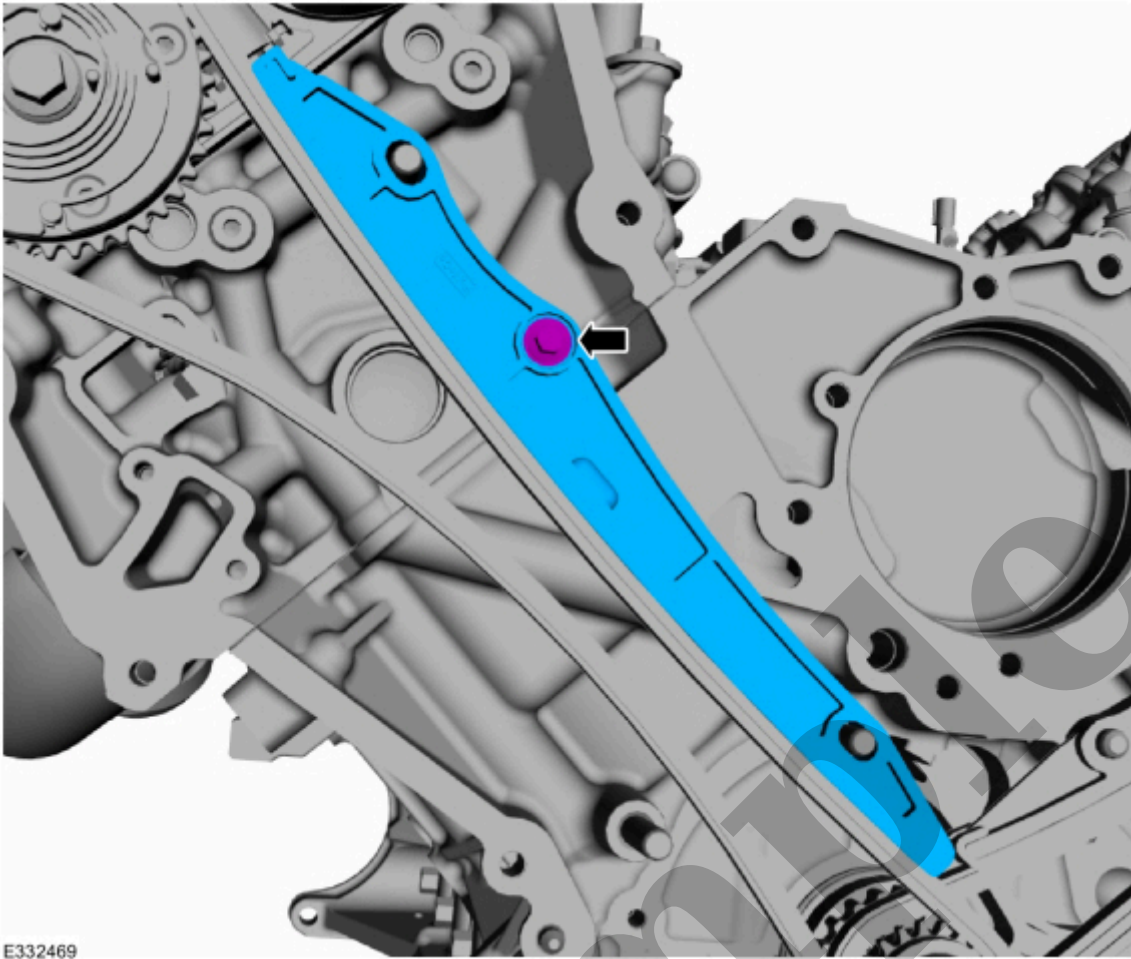

[Click here to learn about symbols, color coding, and icons used in this manual.](#)

69. Remove the RH (right-hand) timing chain.

71. Remove the bolts and the camshaft cap.

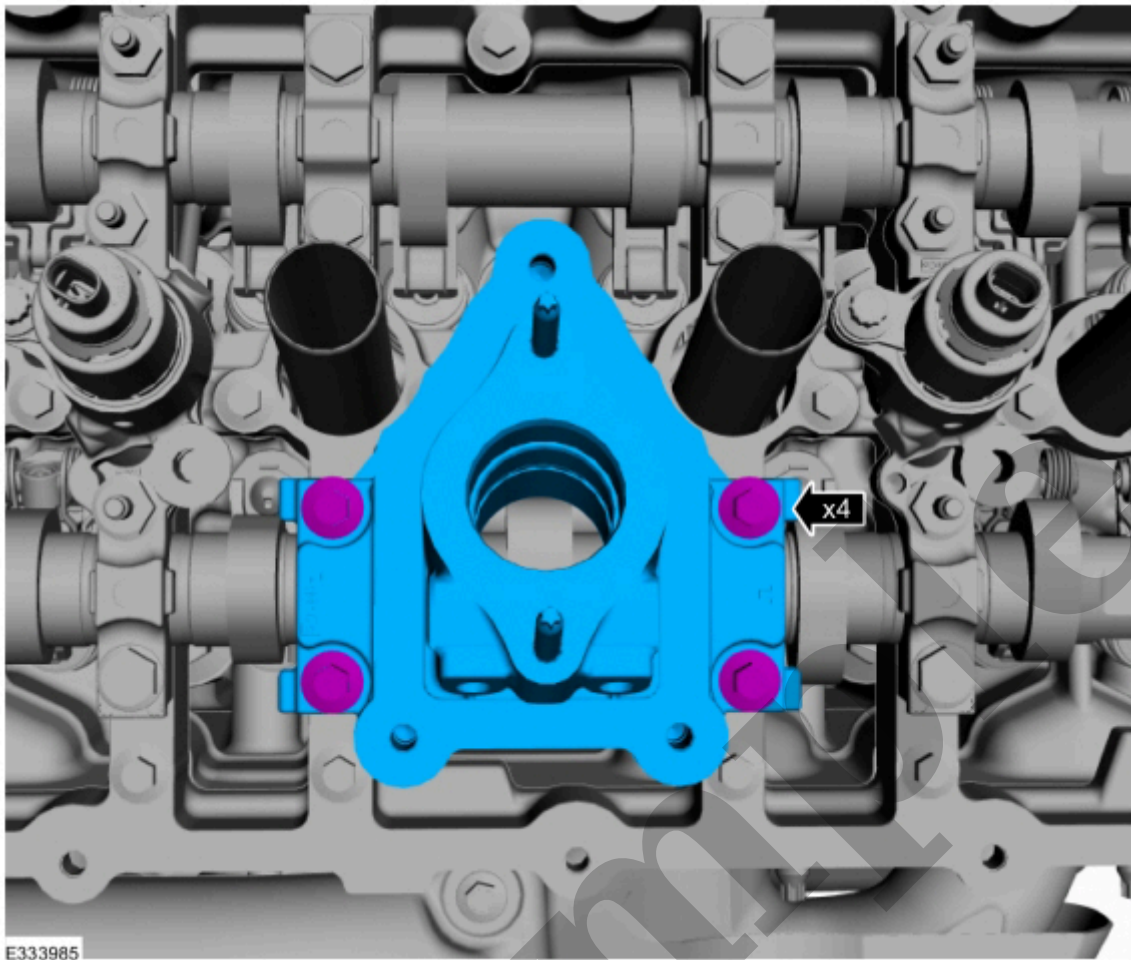

[Click here to learn about symbols, color coding, and icons used in this manual.](#)

72. Remove the bolts and the camshaft and carrier assembly.

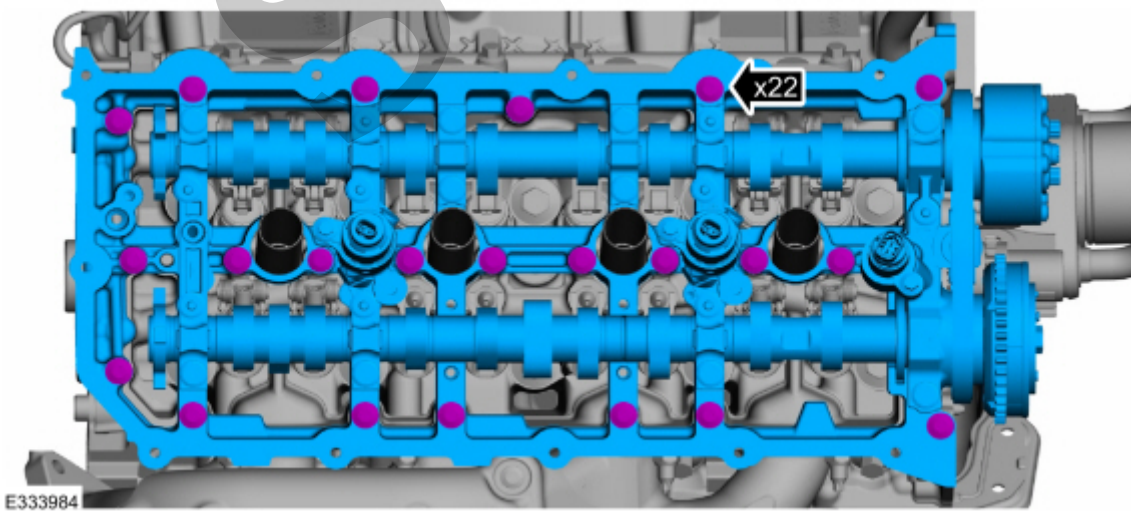

[Click here to learn about symbols, color coding, and icons used in this manual.](#)

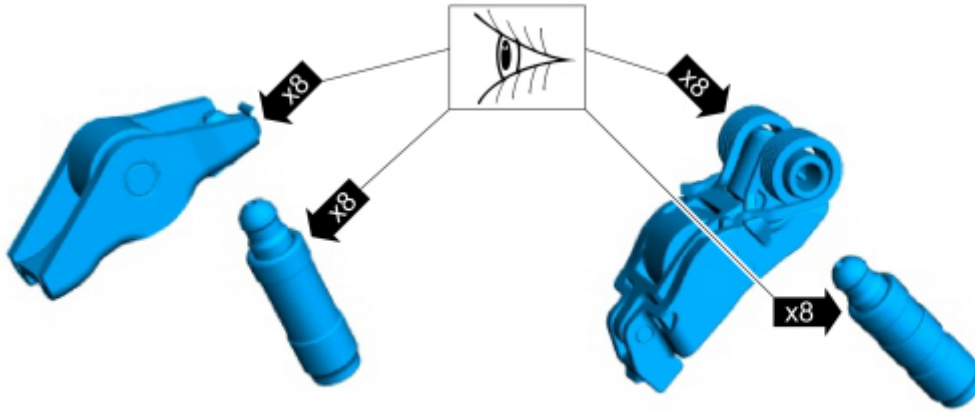

E335916

[Click here to learn about symbols, color coding, and icons used in this manual.](#)

76. • Remove and discard the bolts.
- Remove the cylinder head.

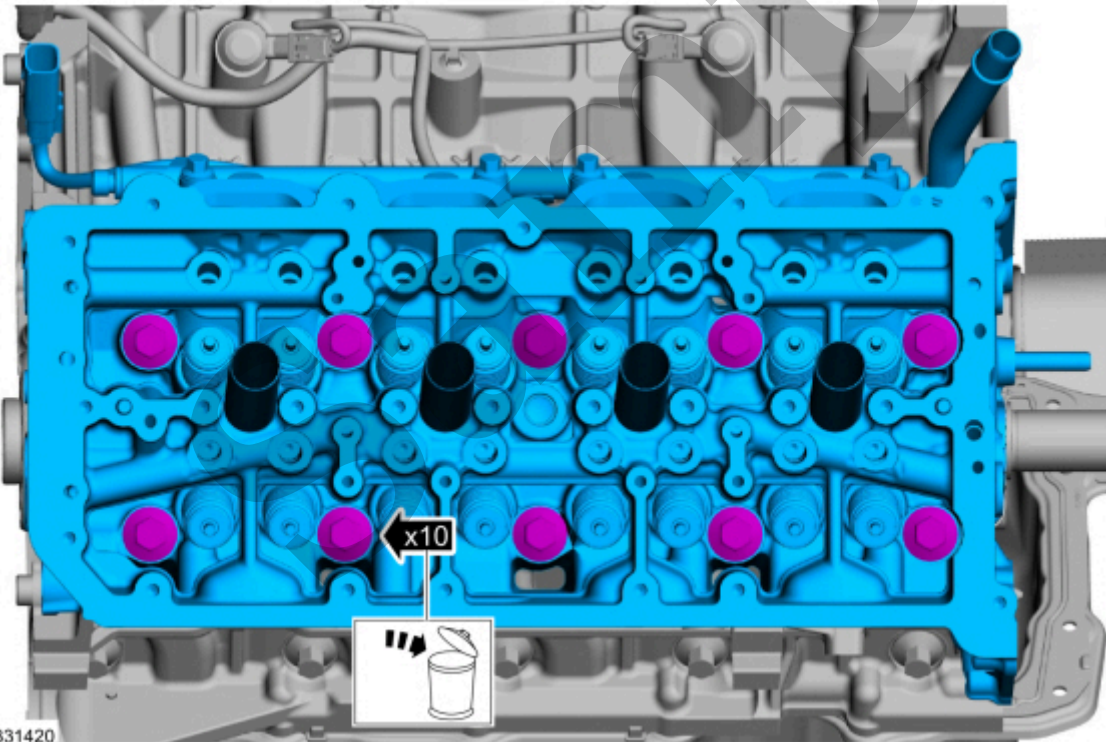

E331420

[Click here to learn about symbols, color coding, and icons used in this manual.](#)

77. Remove and discard the cylinder head gasket.

- Clean and inspect the cylinder head-to-cylinder block mating surfaces of both the cylinder head and the cylinder block
- Refer to: [Cylinder Head Distortion](#)(303-00 Engine System - General Information, General Procedures).
- Refer to: [Cylinder Block Distortion](#)(303-00 Engine System - General Information, General Procedures).

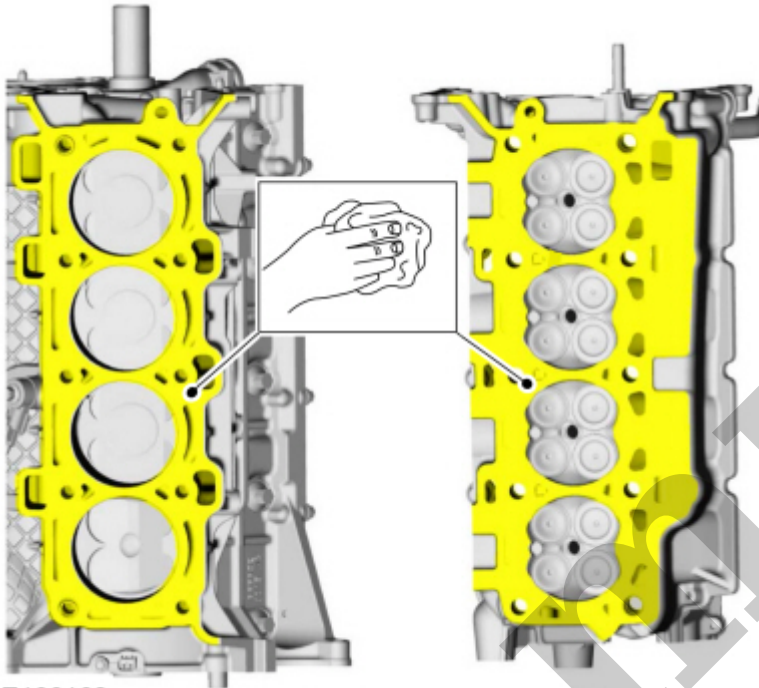

E186162

[Click here to learn about symbols, color coding, and icons used in this manual.](#)

80. Using the special tool, rotate the crankshaft clockwise one complete revolution.

Use Special Service Tool : 303-448 (T93P-6303-A) Holding Tool, Crankshaft