

Your Ultimate Source for OEM Repair Manuals

FactoryManuals.net is a great resource for anyone who wants to save money on repairs by doing their own work. The manuals provide detailed instructions and diagrams that make it easy to understand how to fix a vehicle.

2013 Volvo XC90 Manual - Complete Service & Repair

[Go to manual page](#)

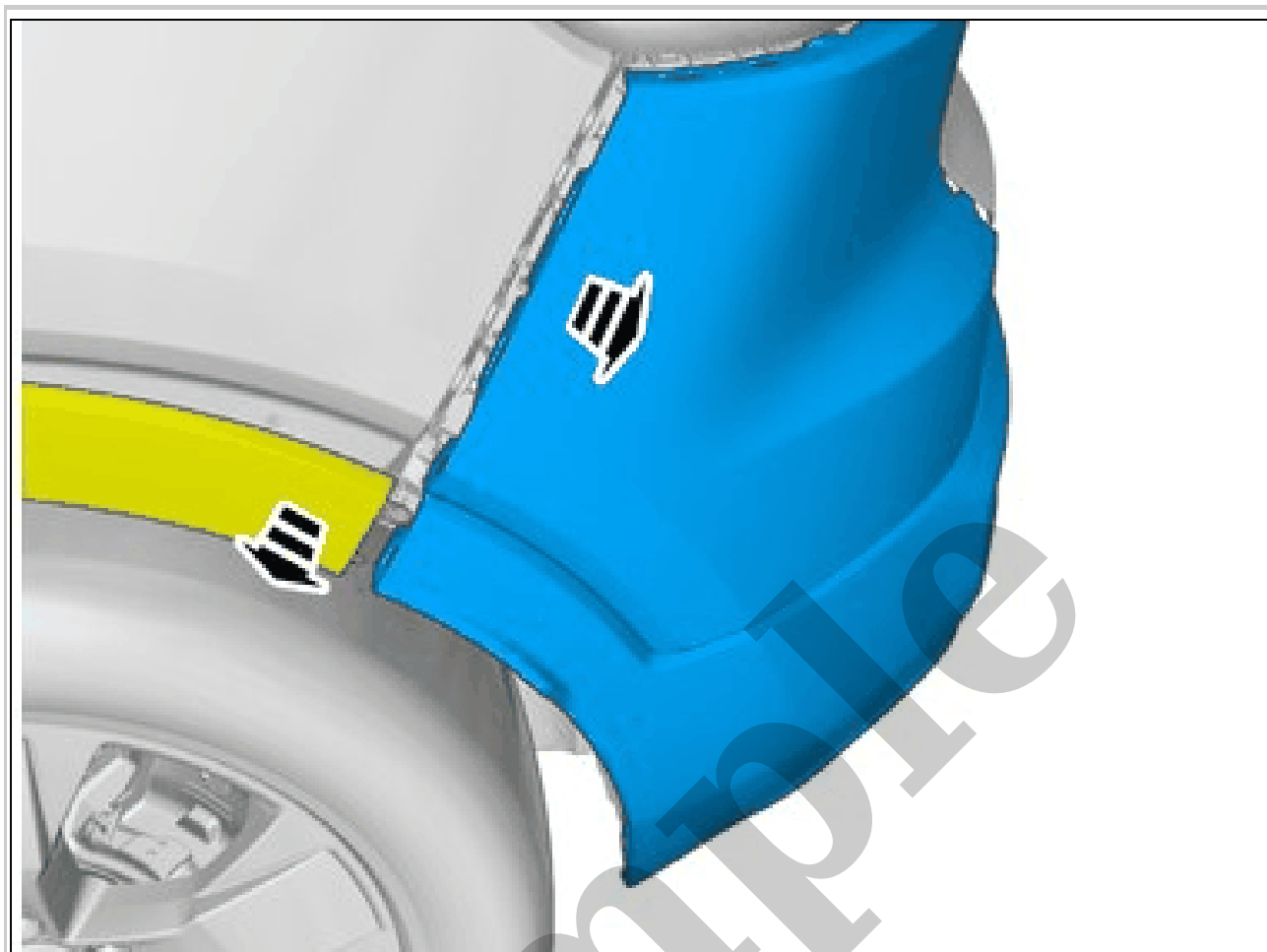

Courtesy of VOLVO CARS CORPORATION

CAUTION: *Be extra careful when removing or installing this component.*

Loosen the component indicated. Do not remove it.

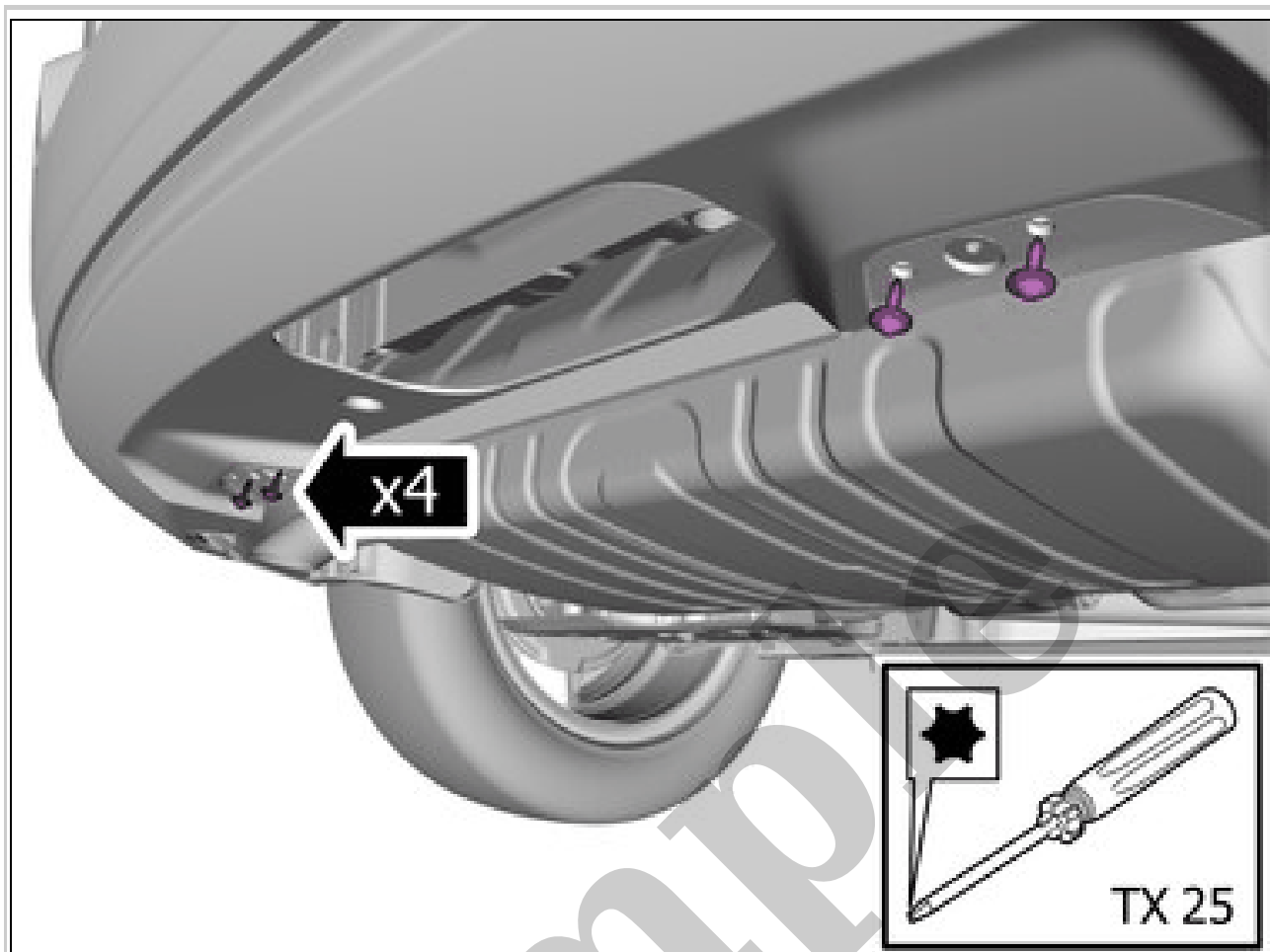

Courtesy of VOLVO CARS CORPORATION

Remove the screws.

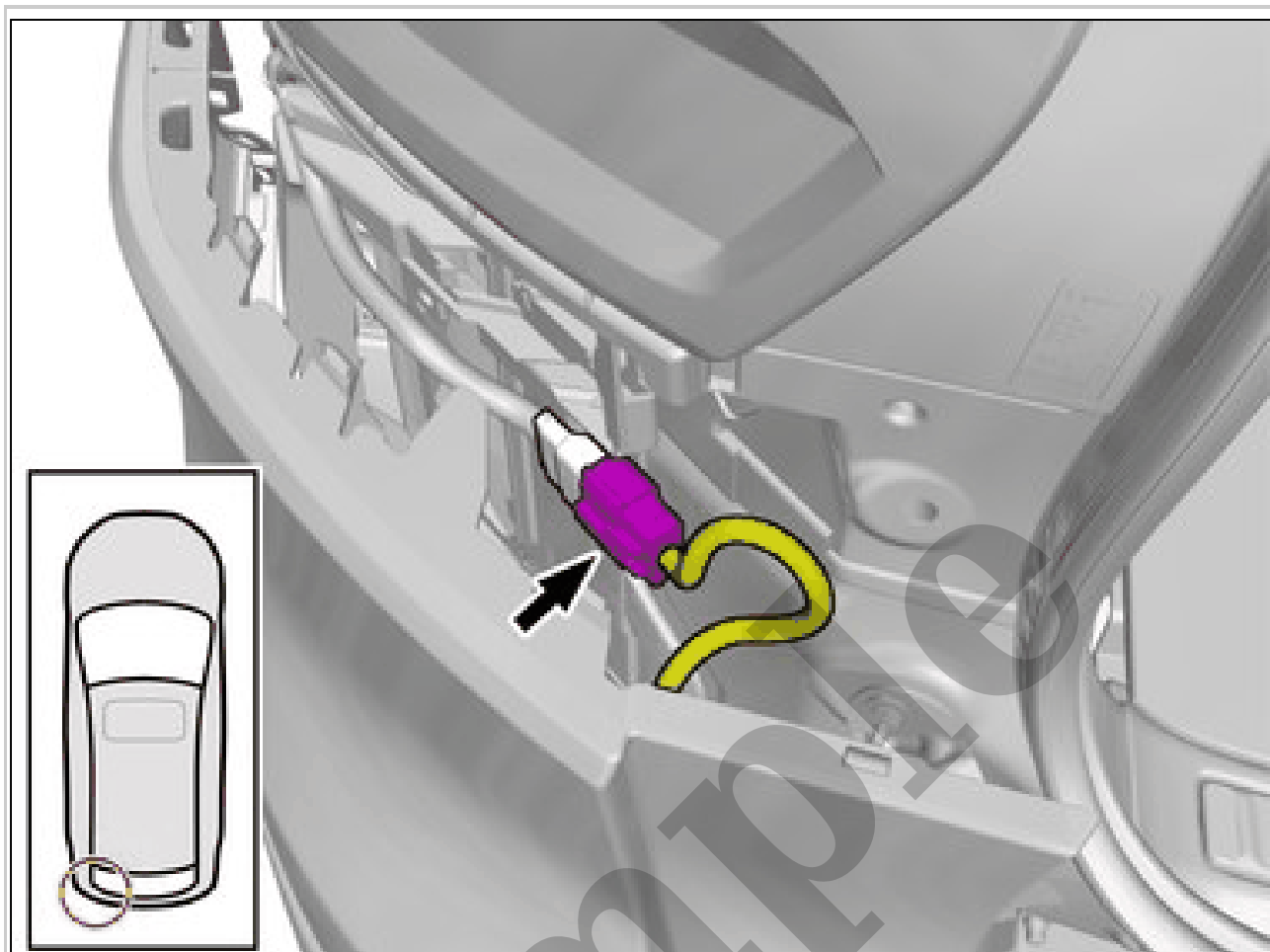

Courtesy of VOLVO CARS CORPORATION

Disconnect the connector.

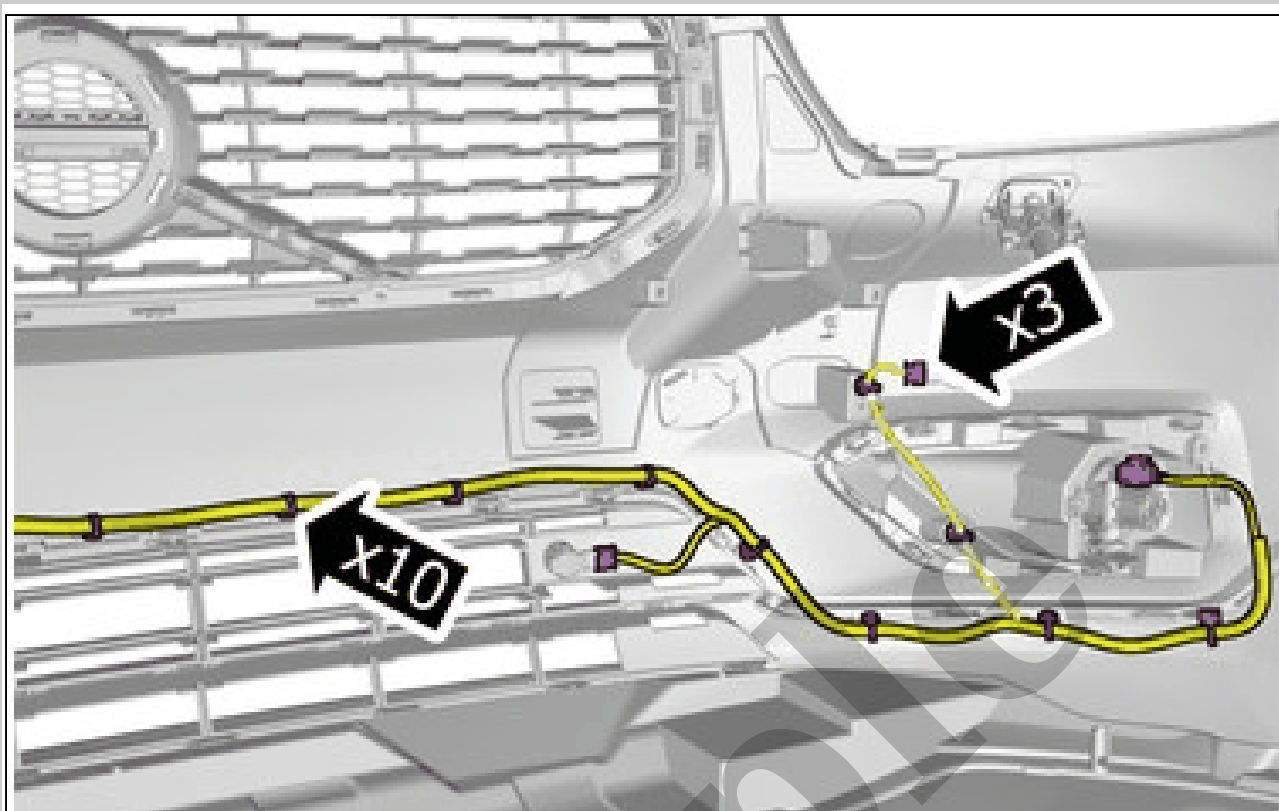

Courtesy of VOLVO CARS CORPORATION

NOTE: *The number of connectors may vary depending on the vehicle's equipment level.*

Disconnect the connectors.
Remove the cable harness clips.

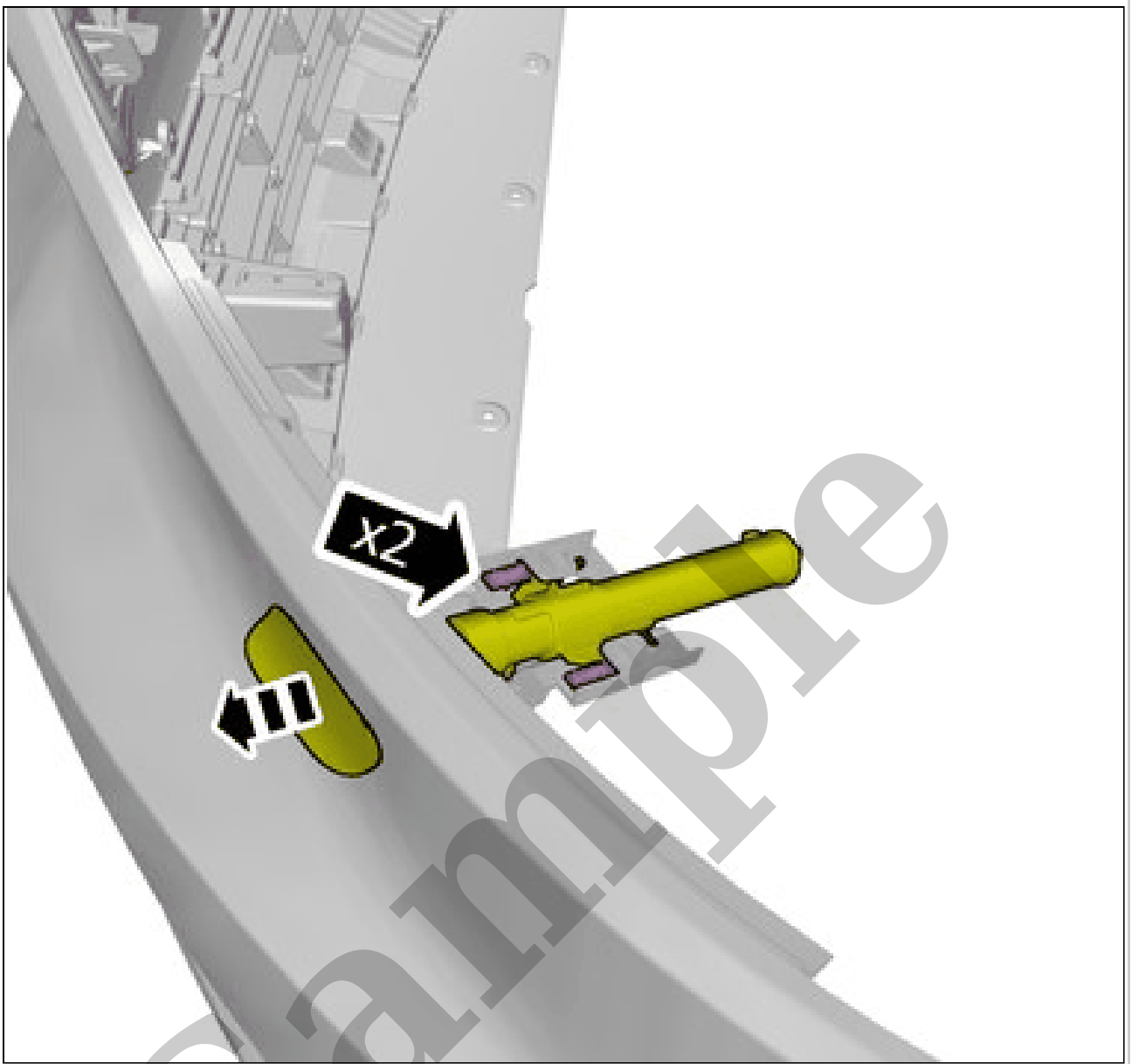

Courtesy of VOLVO CARS CORPORATION

Remove the part carefully
On both sides.

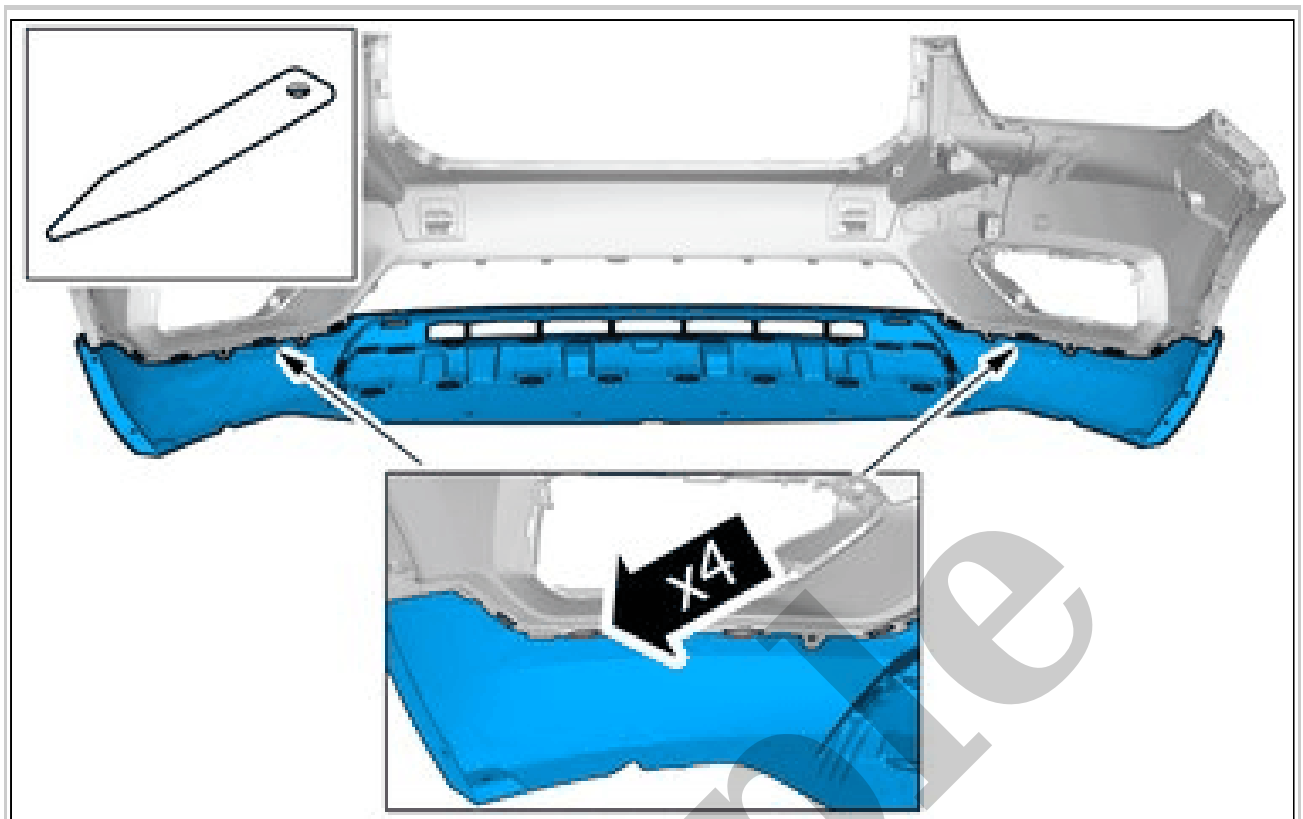

Courtesy of VOLVO CARS CORPORATION

Remove the marked part.

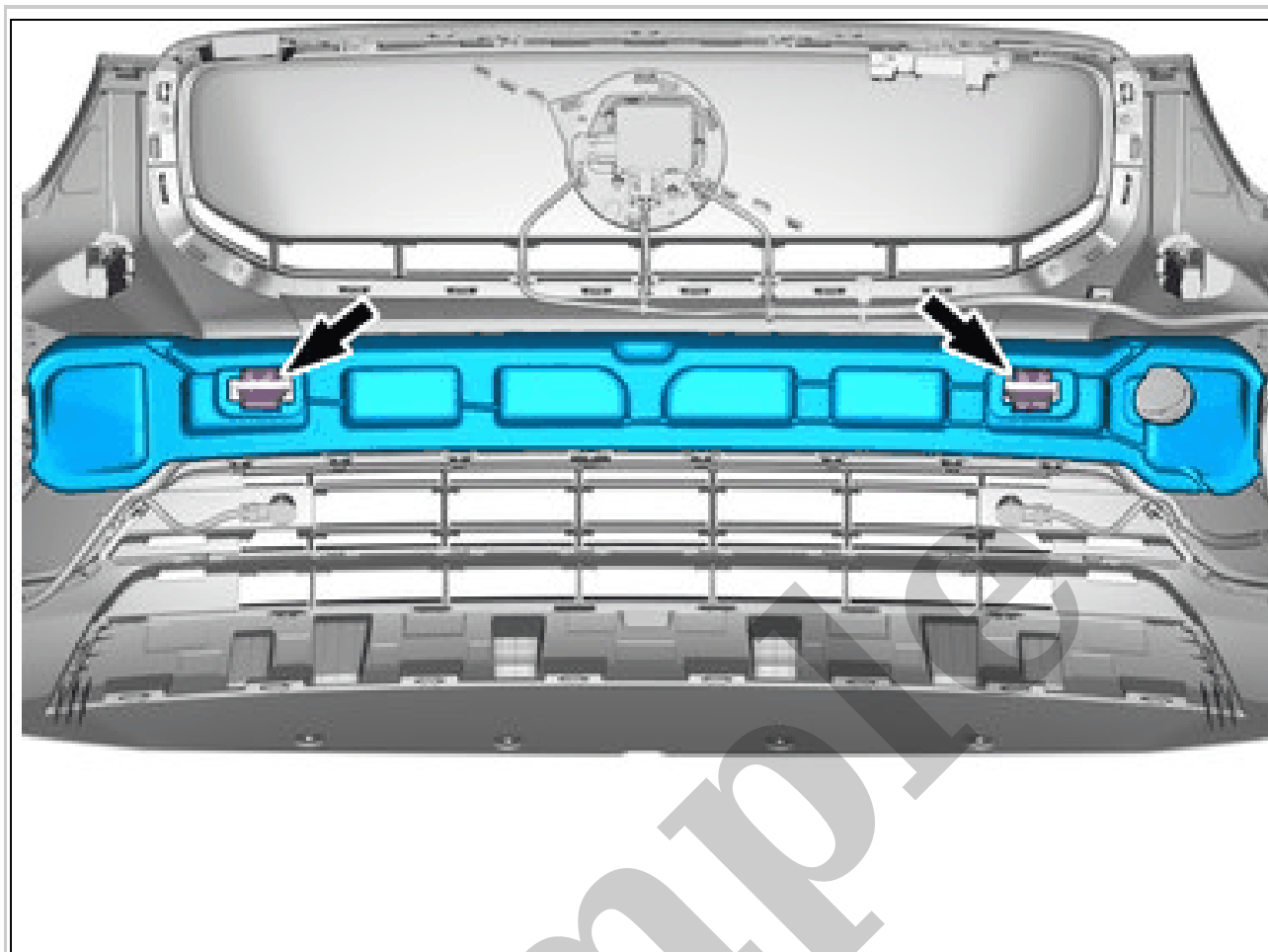

Courtesy of VOLVO CARS CORPORATION

Release the catches.
Remove the marked part.

NOTE: *The number of connectors may vary depending on the vehicle's equipment level.*

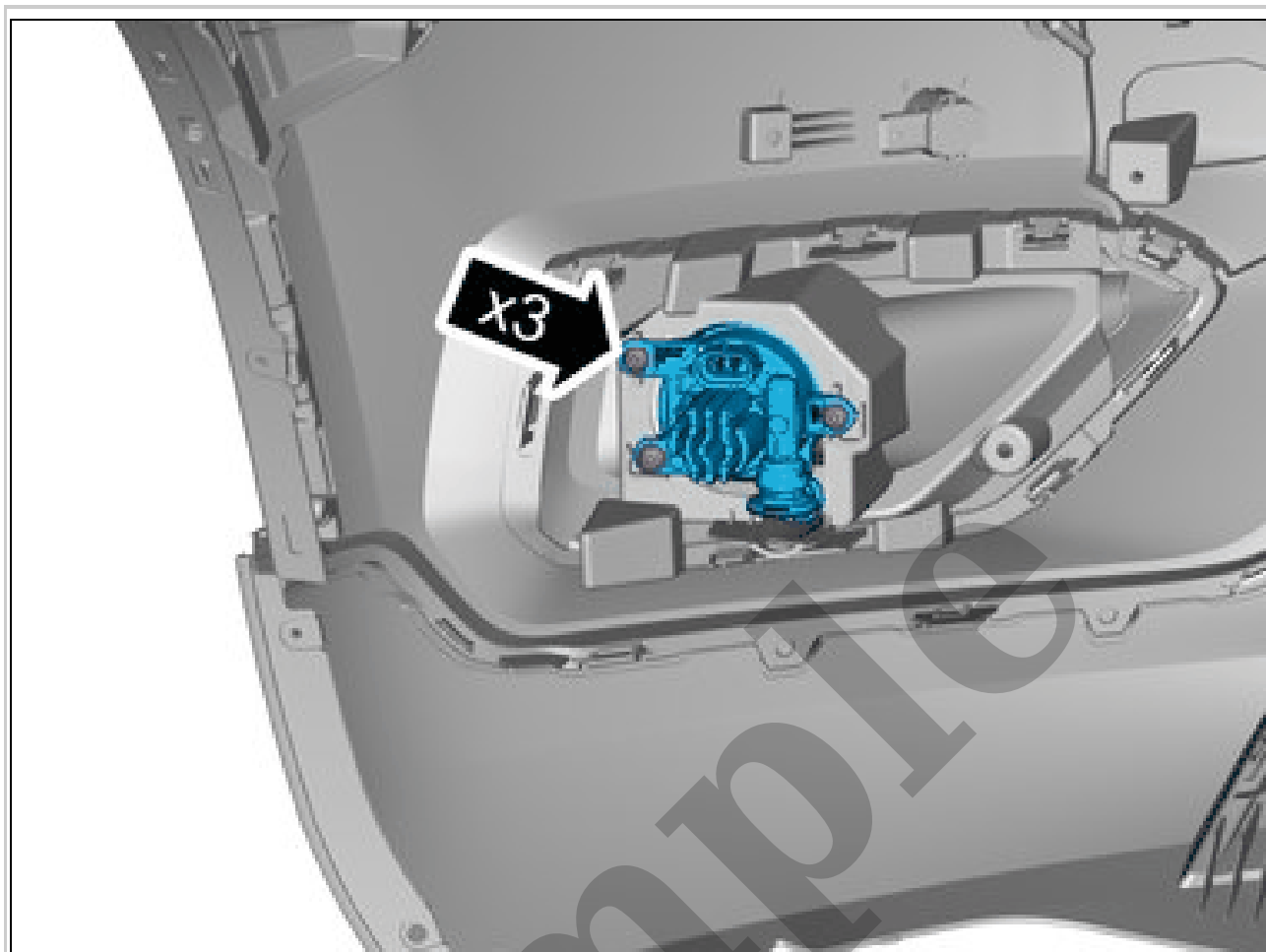

Courtesy of VOLVO CARS CORPORATION

Remove the screws.
Remove the marked part.
Repeat on the other side.

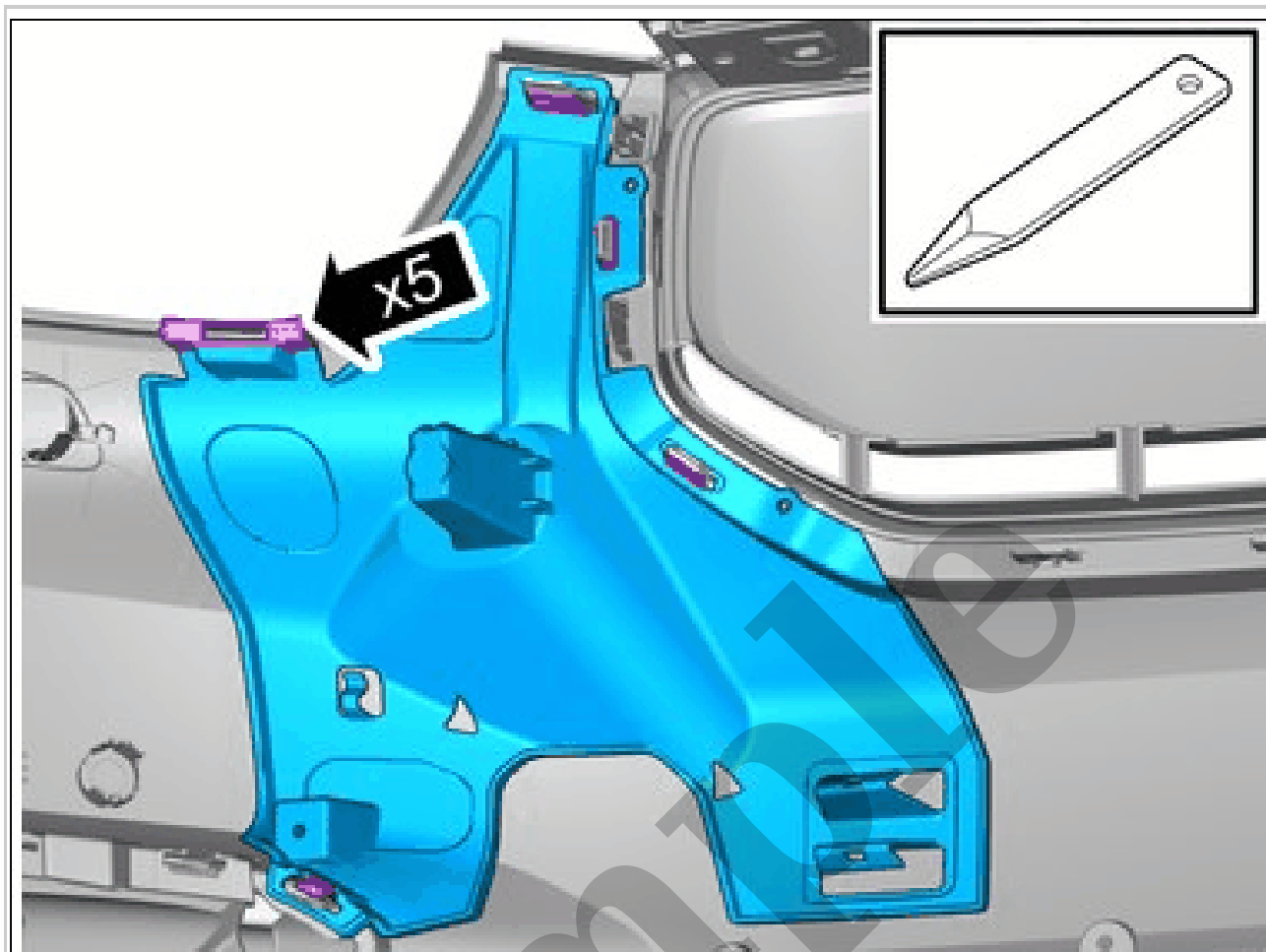

Courtesy of VOLVO CARS CORPORATION

Release the catches.
Remove the marked part.
Repeat on the other side.