

Your Ultimate Source for OEM Repair Manuals

FactoryManuals.net is a great resource for anyone who wants to save money on repairs by doing their own work. The manuals provide detailed instructions and diagrams that make it easy to understand how to fix a vehicle.

2013 VOLVO V70 OEM Service and Repair Workshop Manual

[Go to manual page](#)

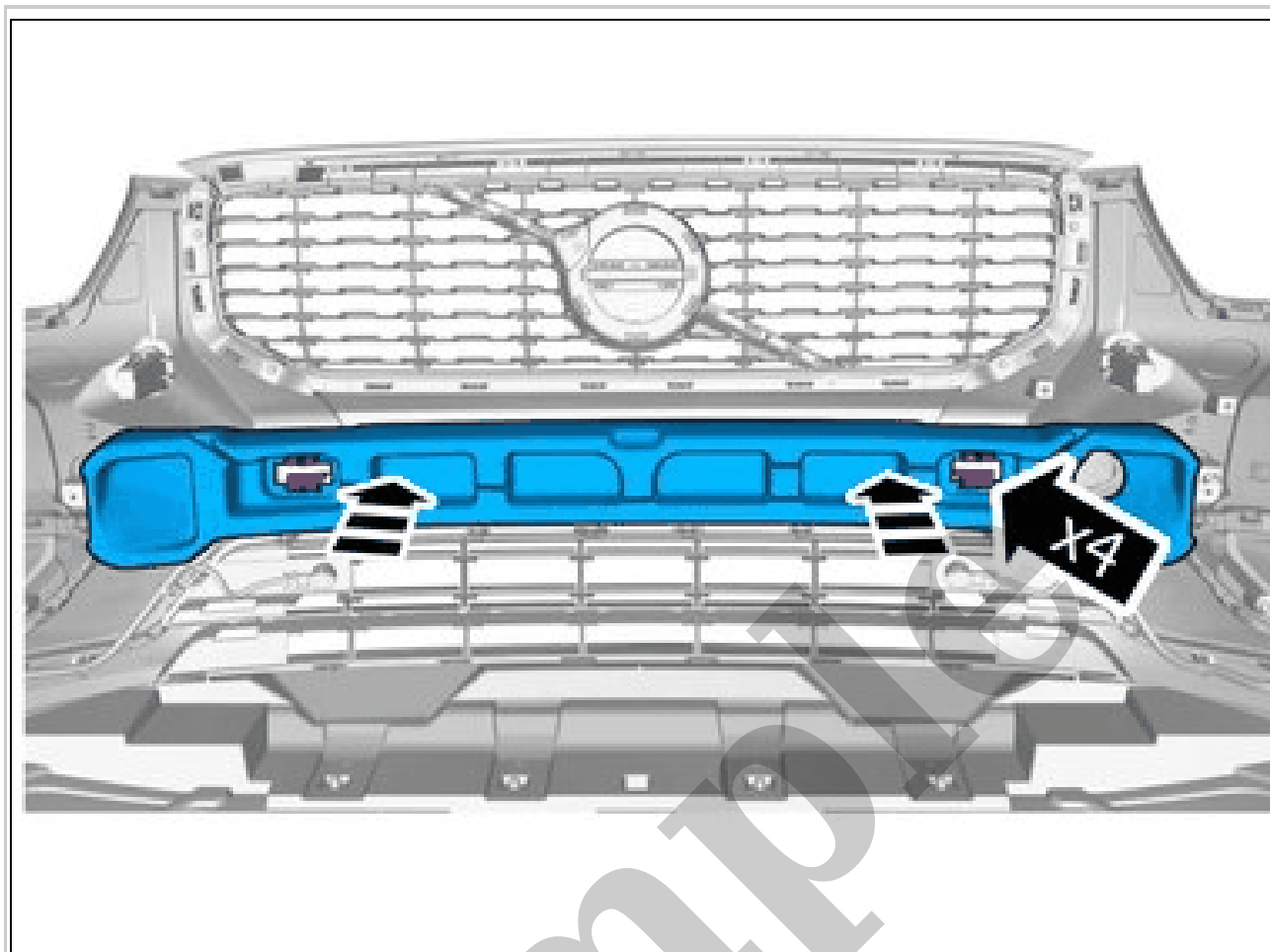

Courtesy of VOLVO CARS CORPORATION

Install the marked component.
Reinstall the removed parts in reverse order.

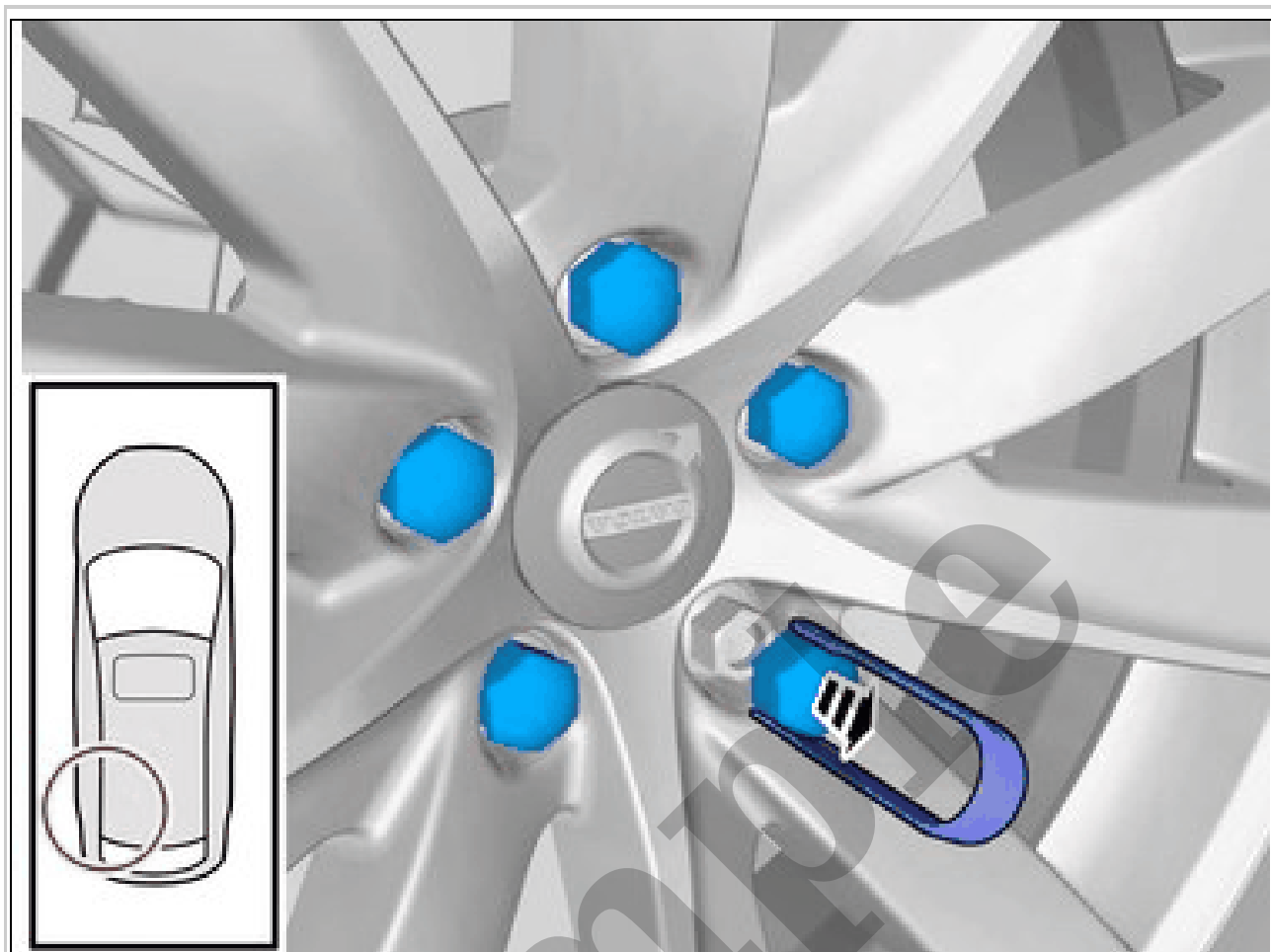

Courtesy of VOLVO CARS CORPORATION

Remove the marked detail/details.

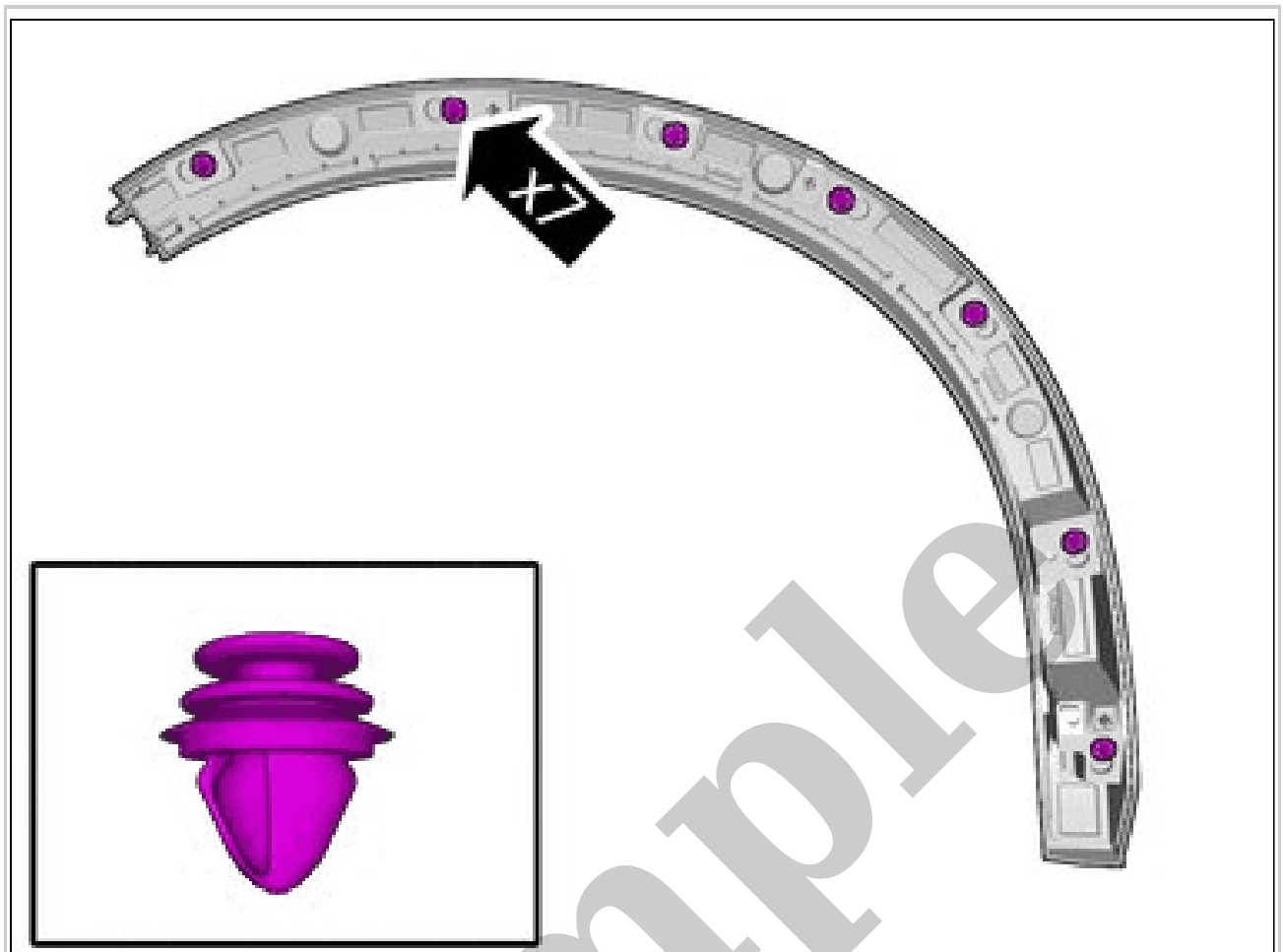

Courtesy of VOLVO CARS CORPORATION

NOTE: *The graphic shows the back of the component before removal.*

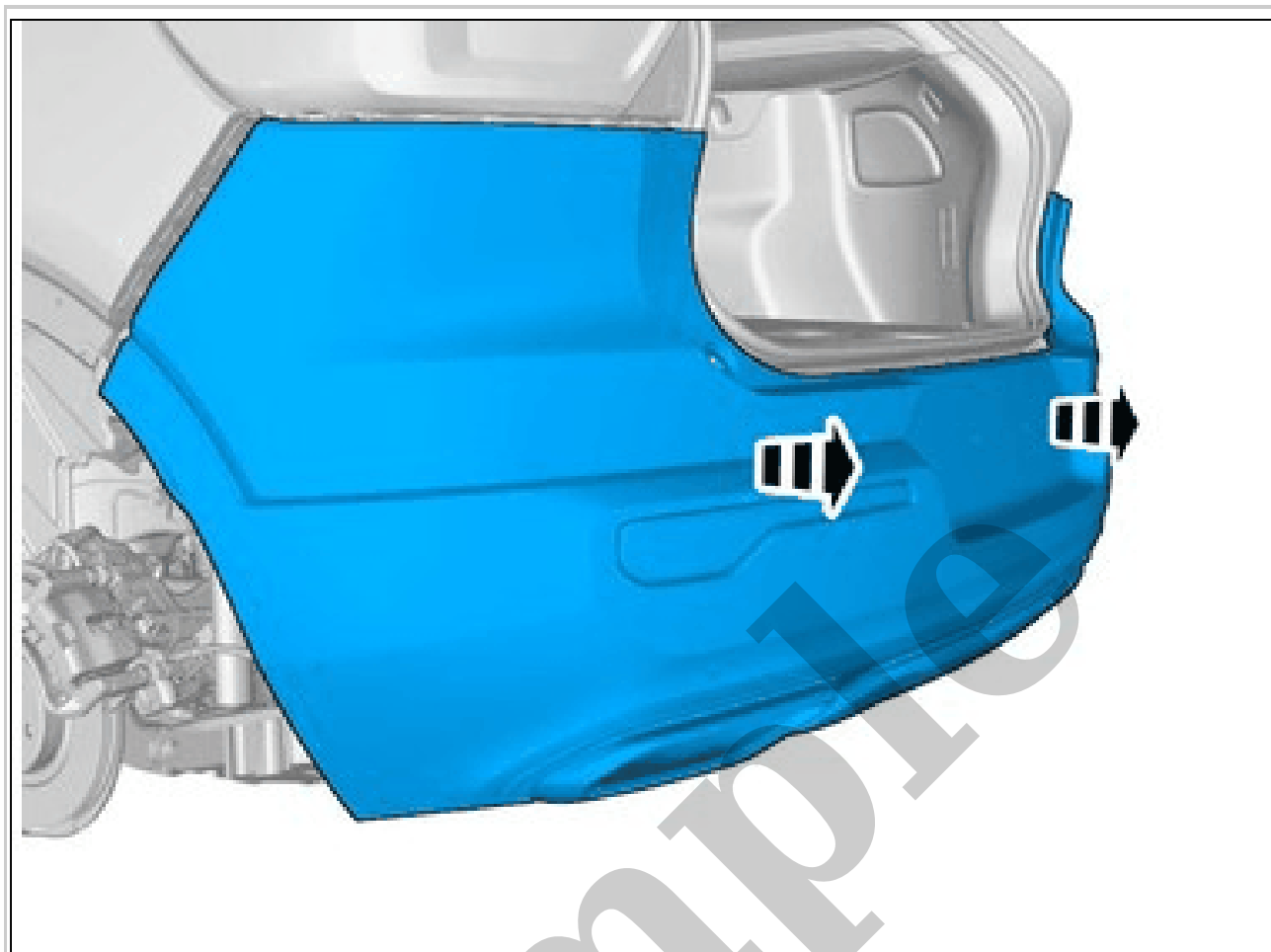

Courtesy of VOLVO CARS CORPORATION

CAUTION: *Place the Bumper Cover on a suitable surface.*

Request the aid of a colleague for this procedure.
Remove the marked part.

VEHICLES WITH FOOT MOVEMENT DETECTION (FMDM)

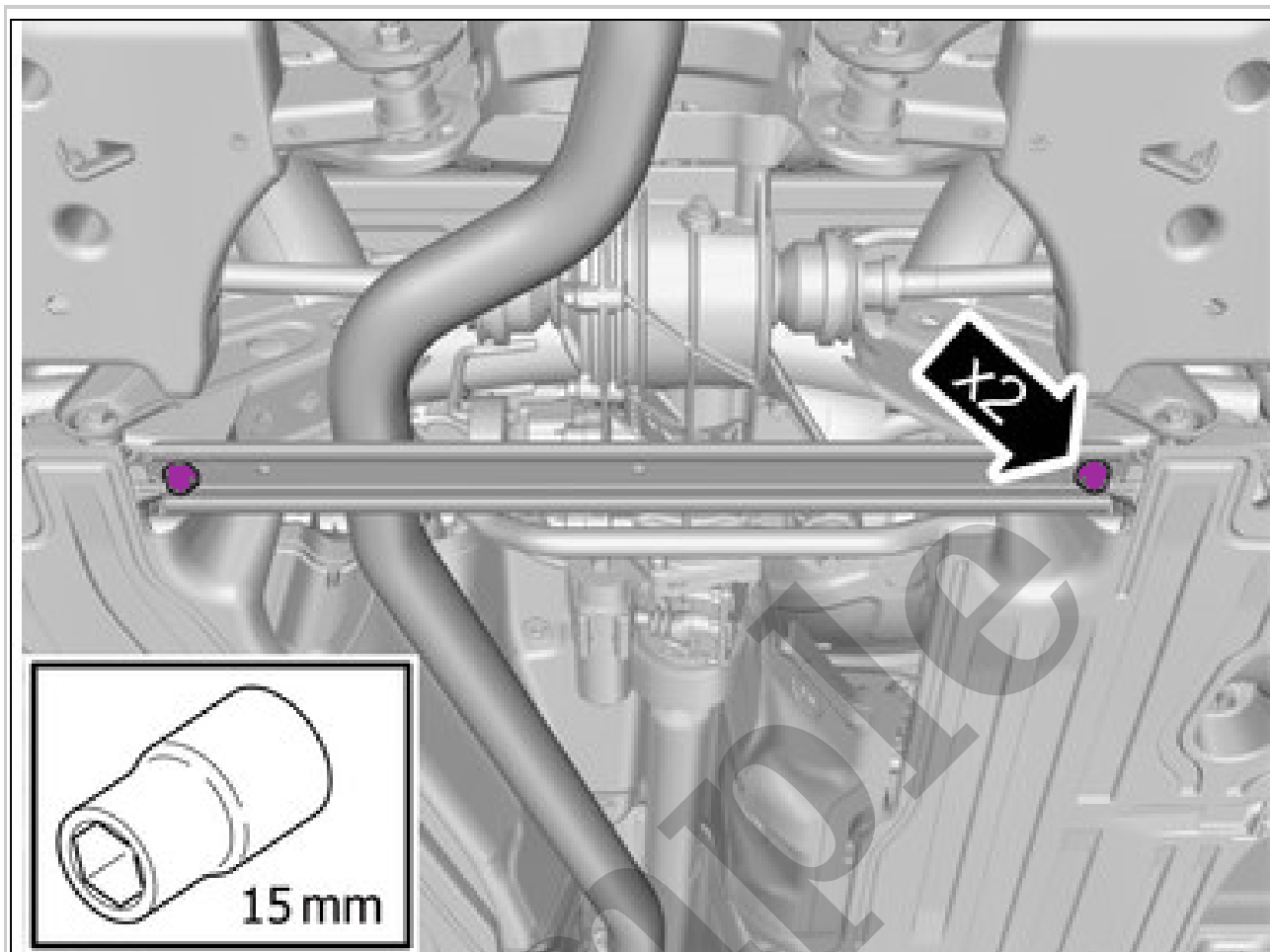

Courtesy of VOLVO CARS CORPORATION

Remove the screws.
The part is not to be reused.

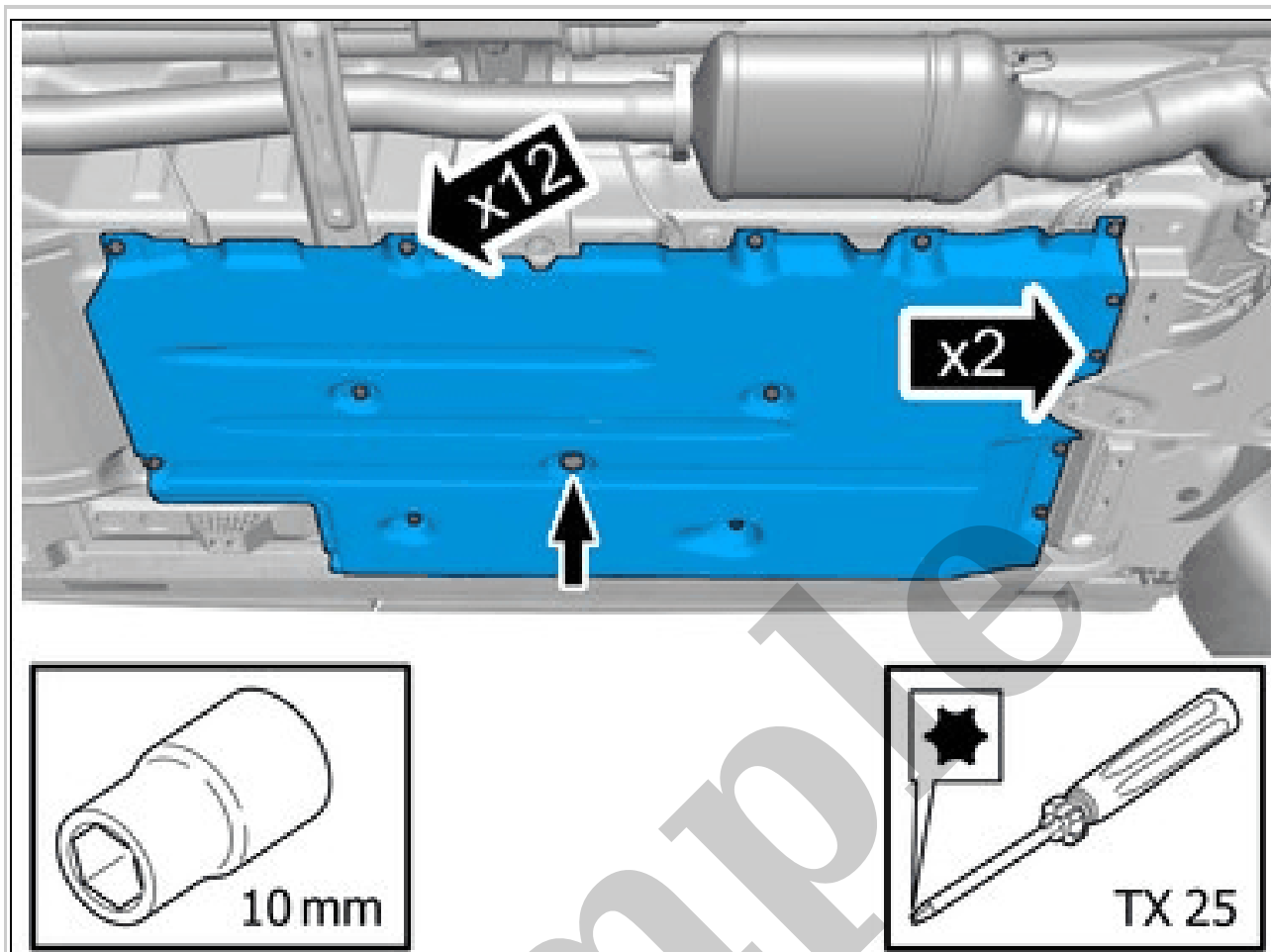

Courtesy of VOLVO CARS CORPORATION

- Remove the screws.
- Remove the nuts.
- Remove the clip.
- Remove the marked part.

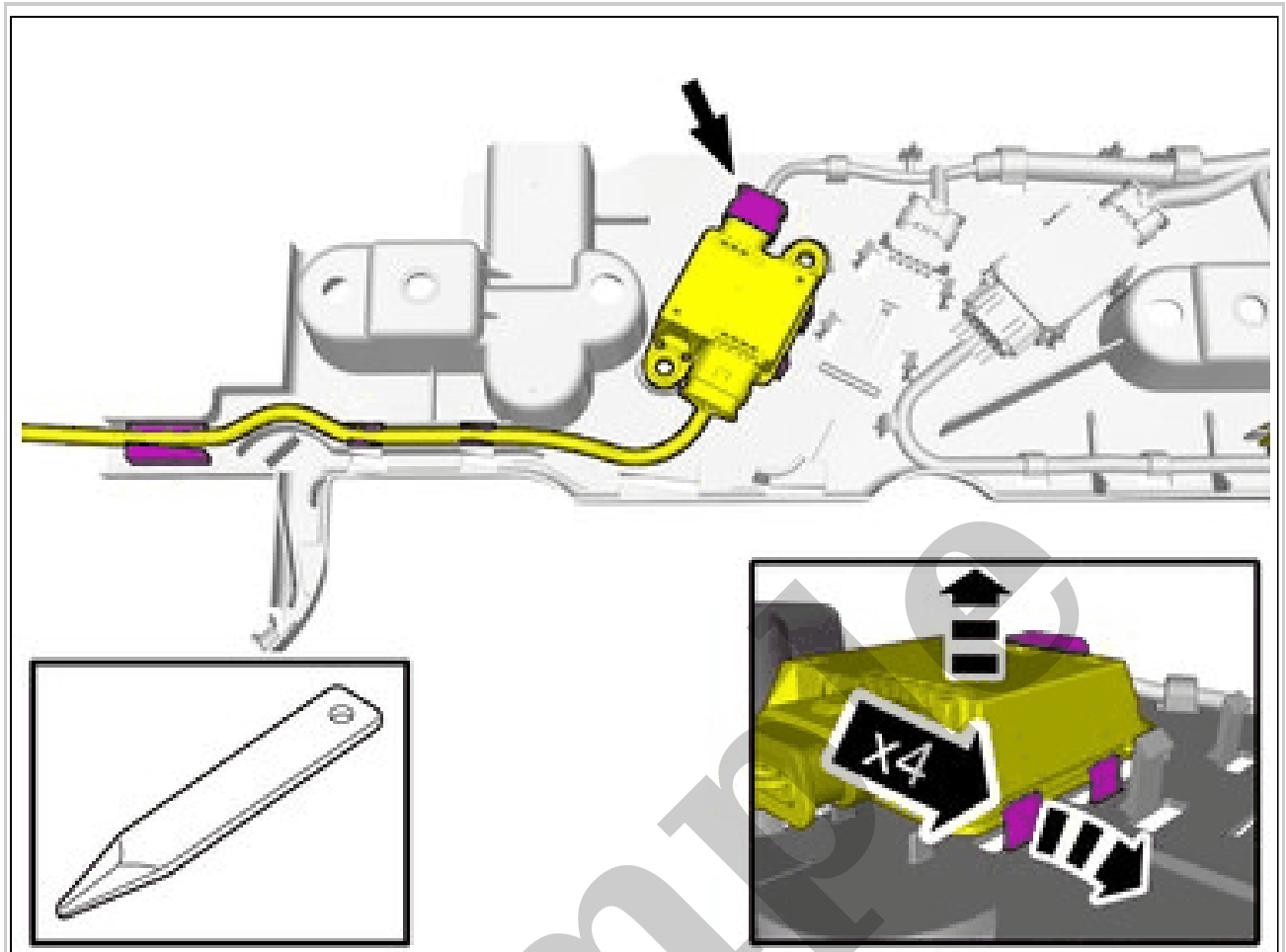

Courtesy of VOLVO CARS CORPORATION

Disconnect the connector.
Remove the cable harness clips.
Fold marked part aside.

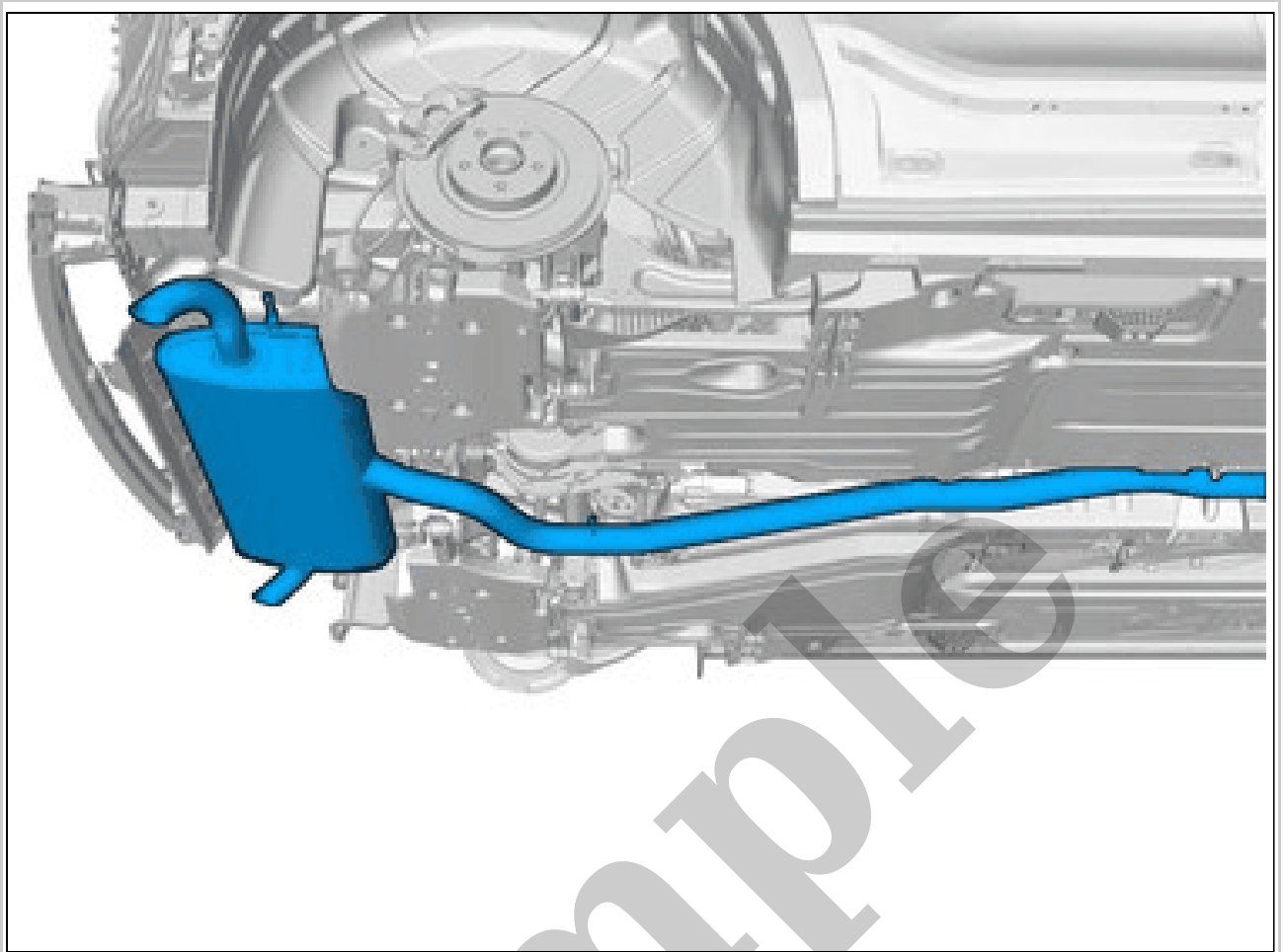

Courtesy of VOLVO CARS CORPORATION

Remove the marked part.

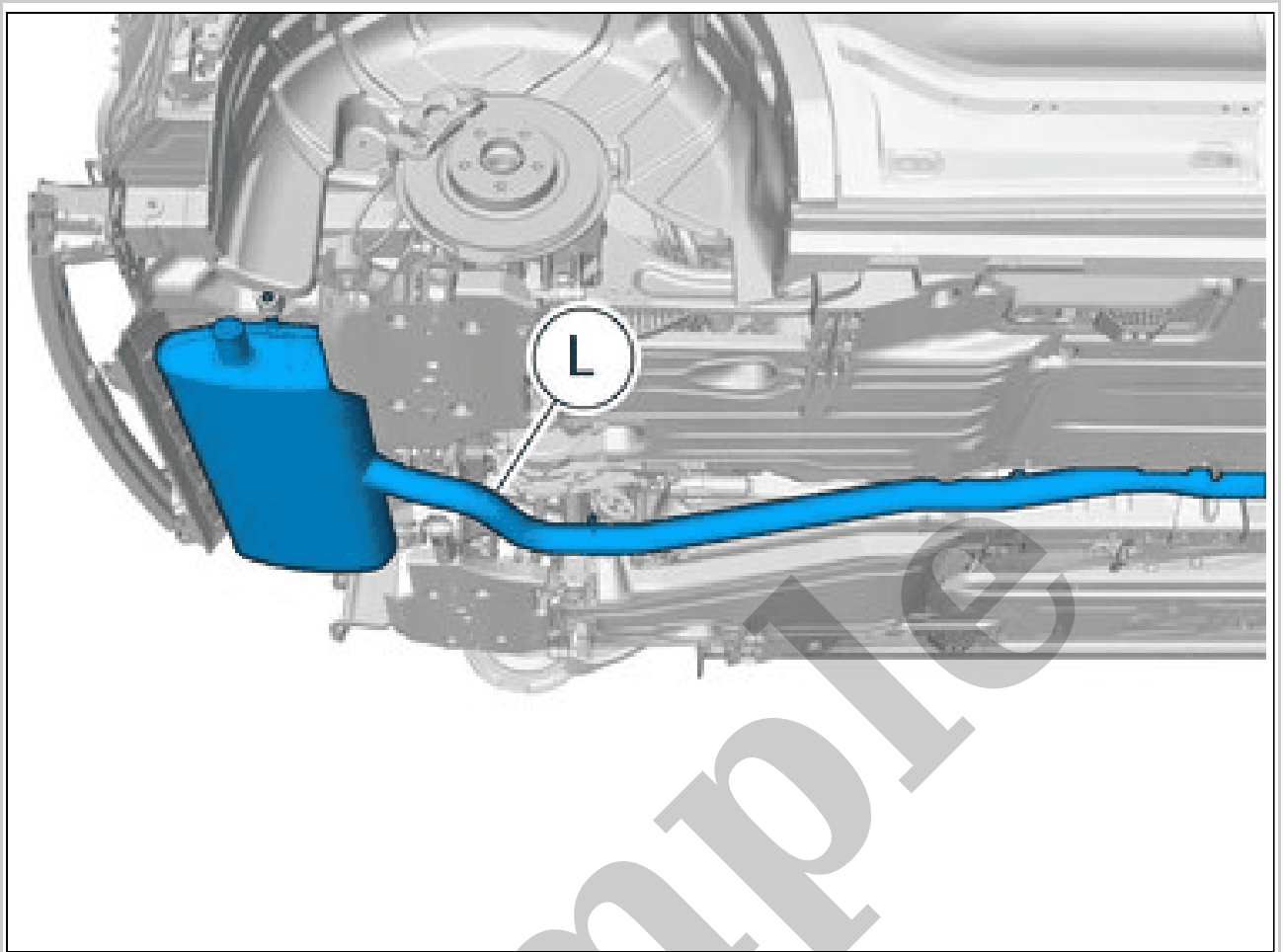

Courtesy of VOLVO CARS CORPORATION

NOTE: *This step is easier with two people.*

Install component that comes with the accessory kit.