

Your Ultimate Source for OEM Repair Manuals

FactoryManuals.net is a great resource for anyone who wants to save money on repairs by doing their own work. The manuals provide detailed instructions and diagrams that make it easy to understand how to fix a vehicle.

2013 VOLVO S60 OEM Service and Repair Workshop Manual

[Go to manual page](#)

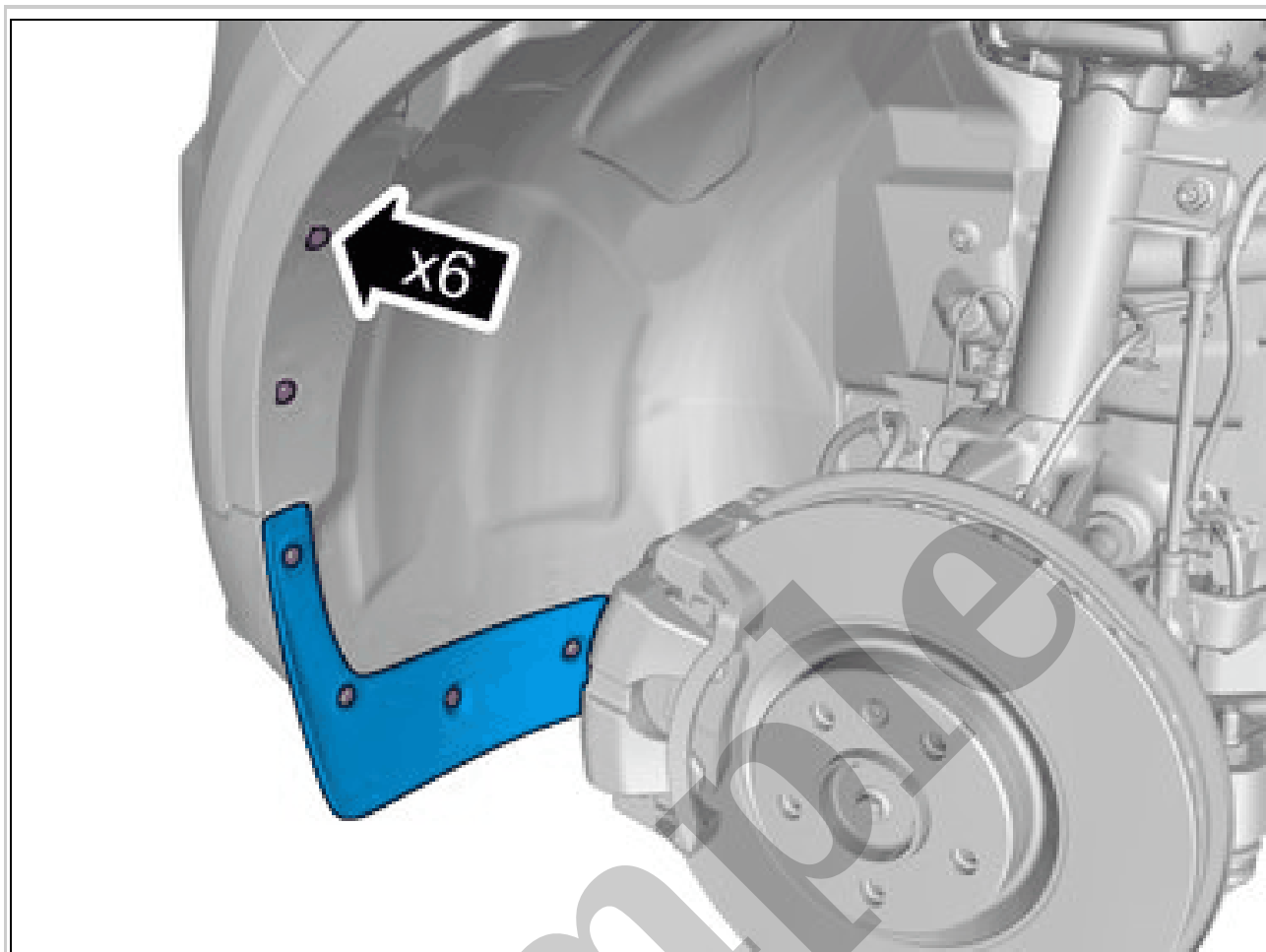

Courtesy of VOLVO CARS CORPORATION

Remove the screws.
Remove the marked part.

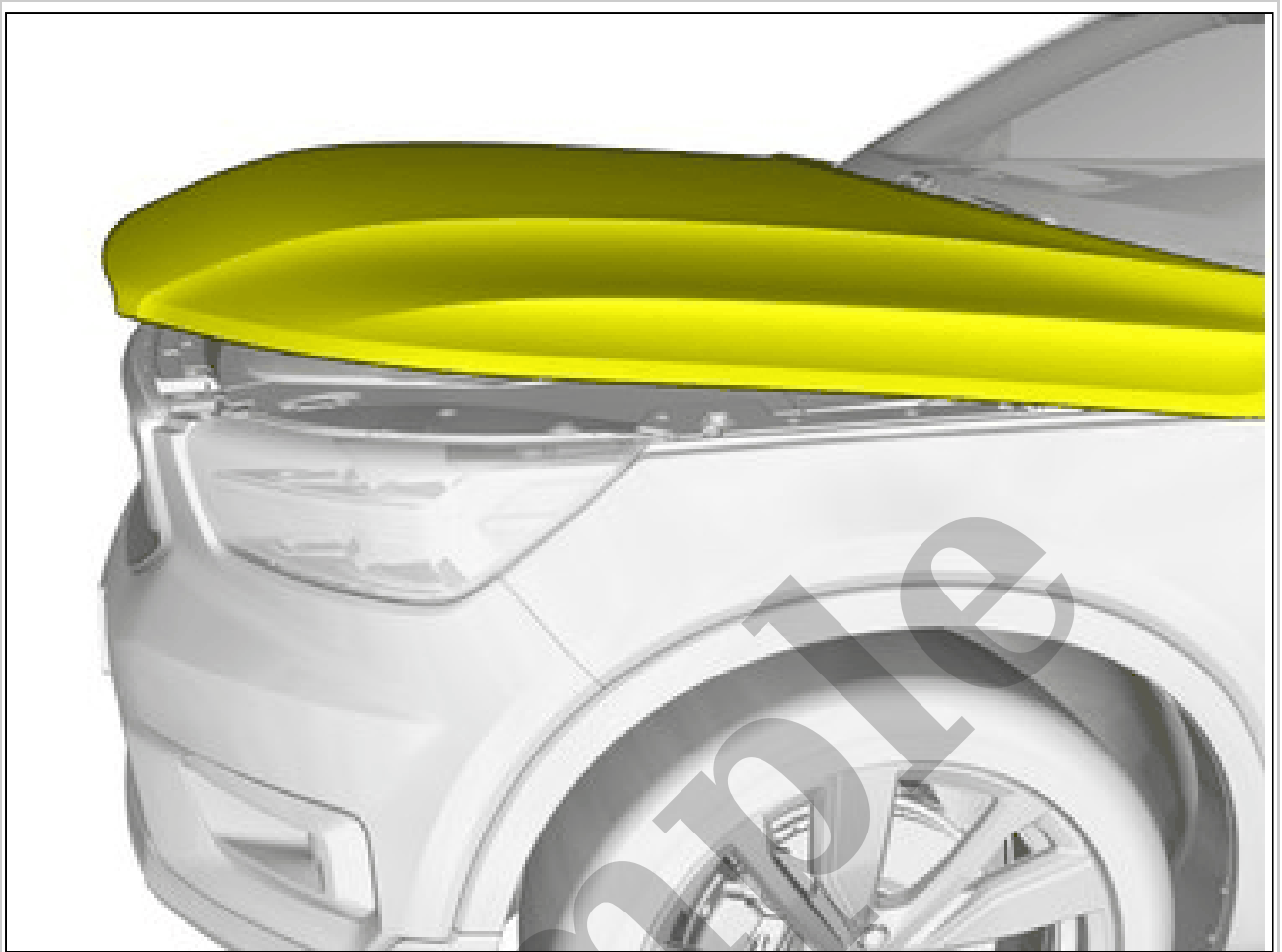

Courtesy of VOLVO CARS CORPORATION

Open the hood.

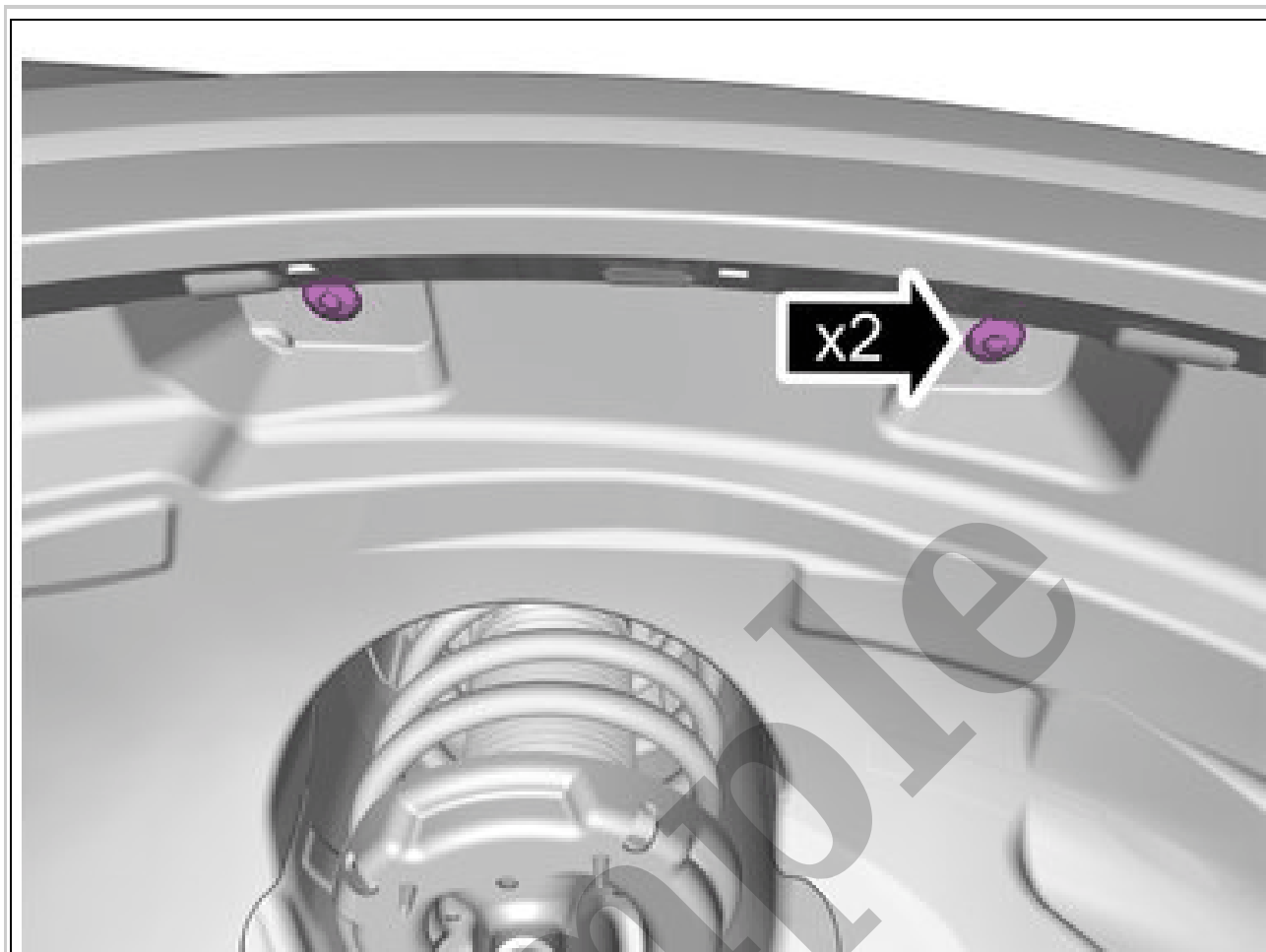

Courtesy of VOLVO CARS CORPORATION

Remove the clips.

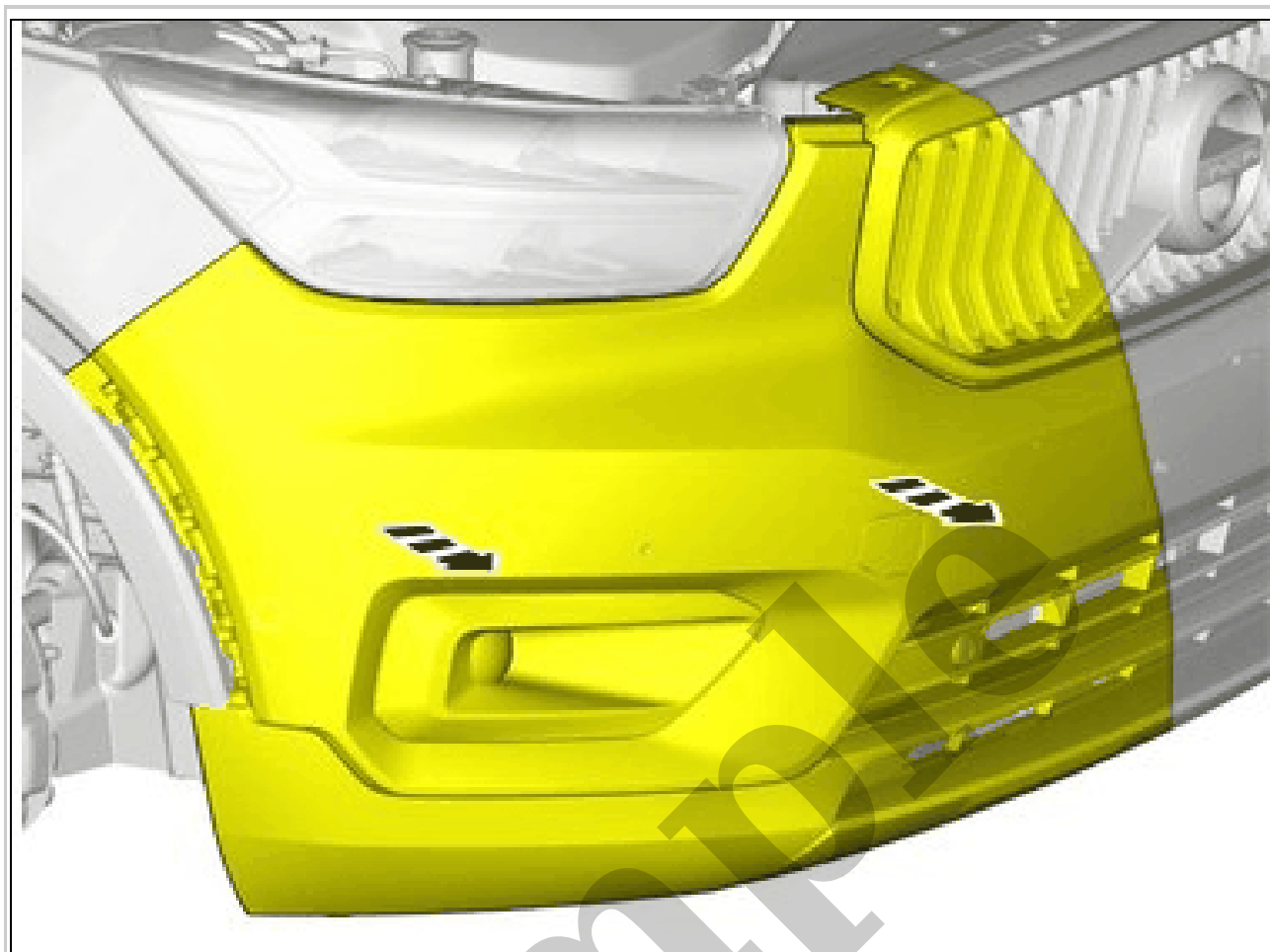

Courtesy of VOLVO CARS CORPORATION

CAUTION: *Make sure not to damage painted surfaces.*

Remove the part carefully
Tilt the component somewhat.

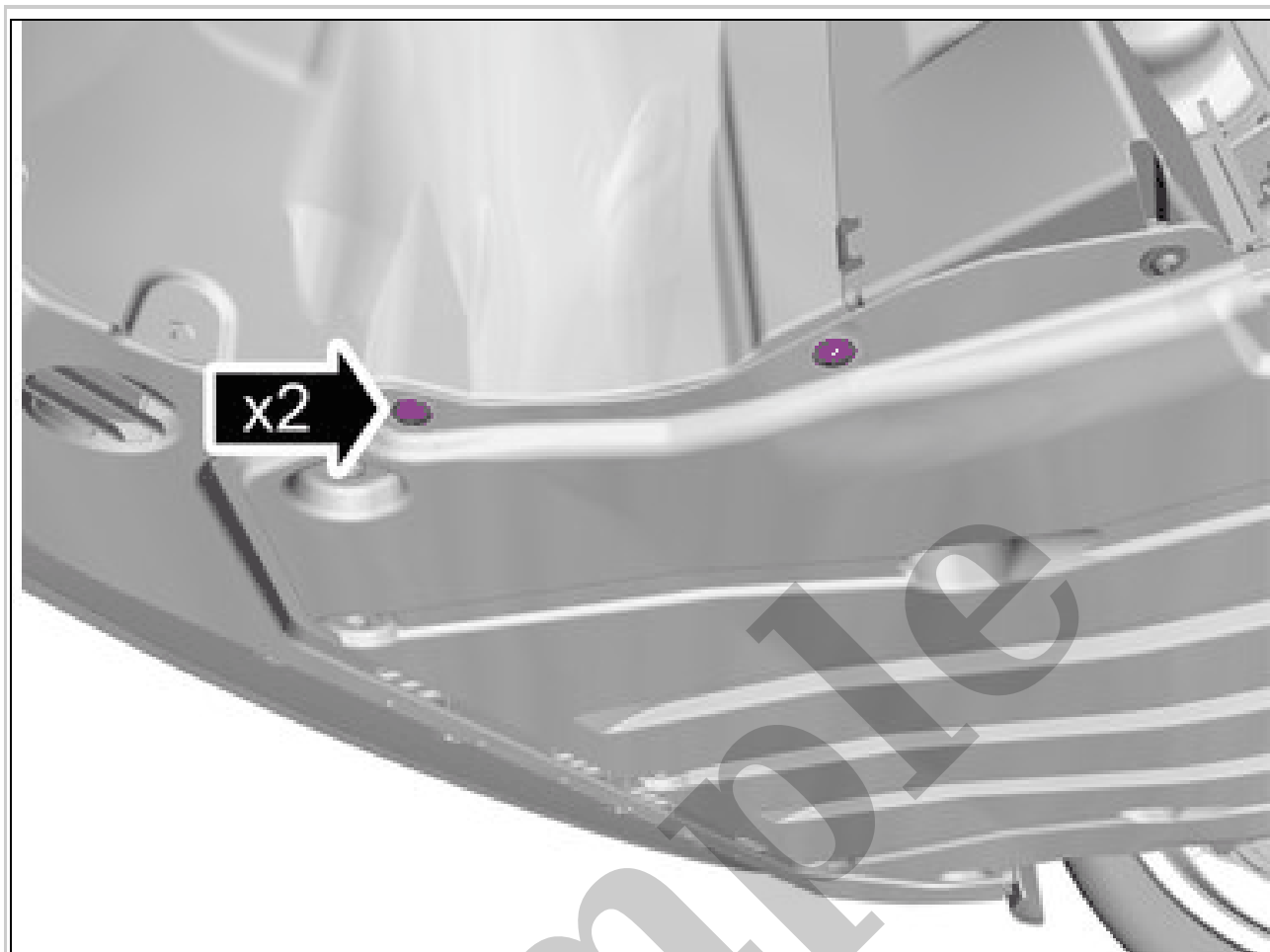

Courtesy of VOLVO CARS CORPORATION

Remove the screws.

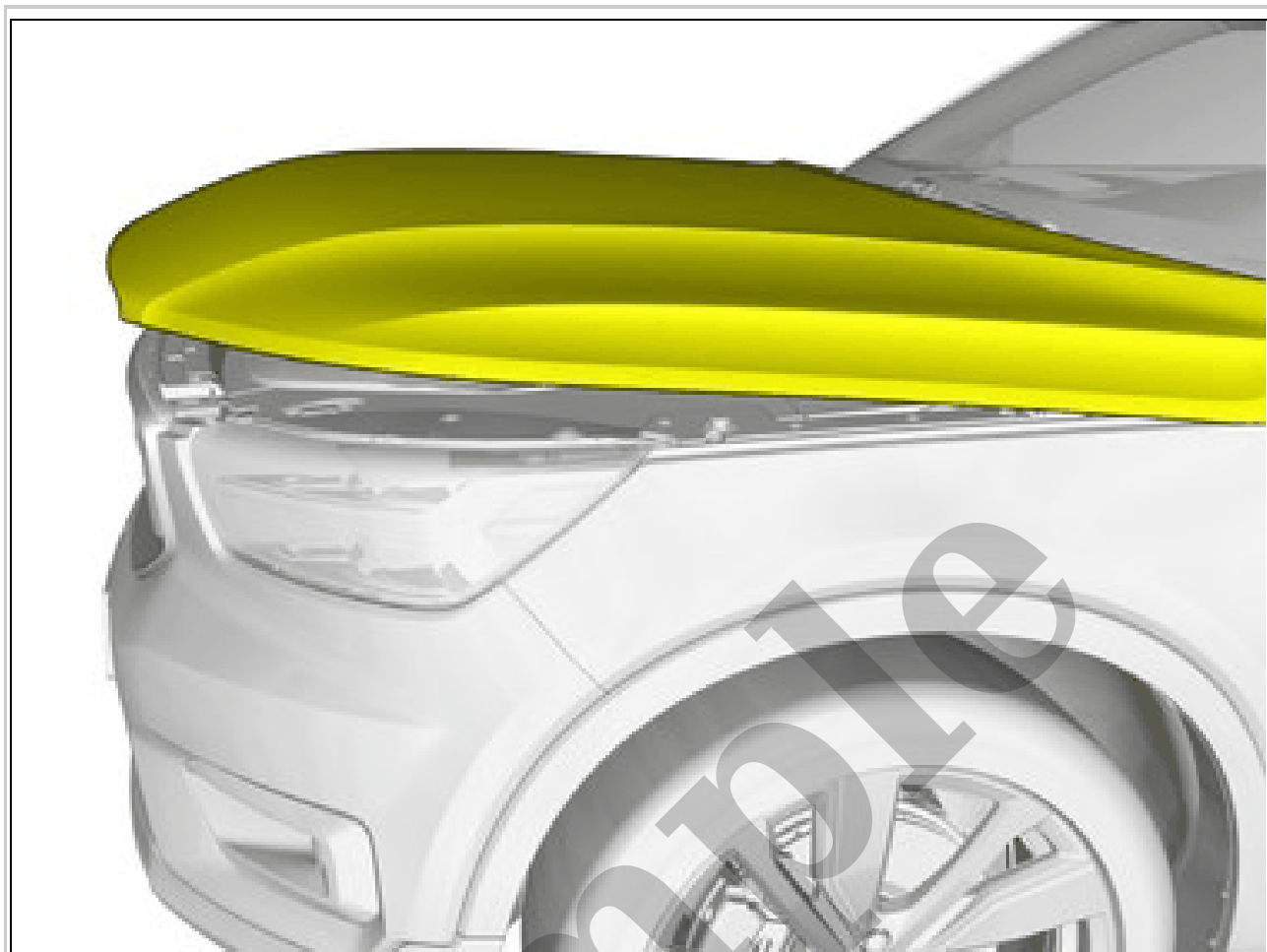

Courtesy of VOLVO CARS CORPORATION

Open the hood.

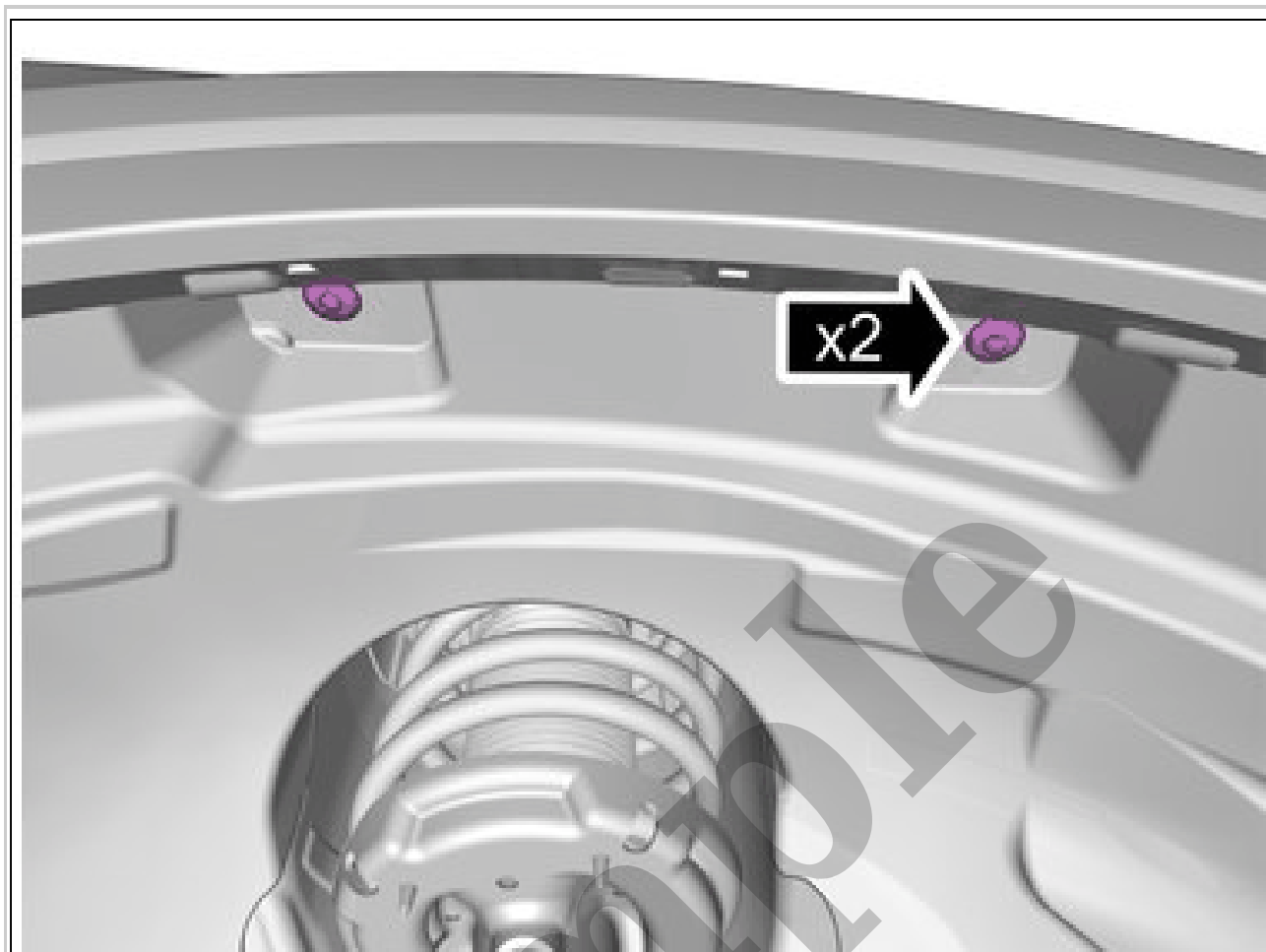

Courtesy of VOLVO CARS CORPORATION

Remove the clips.

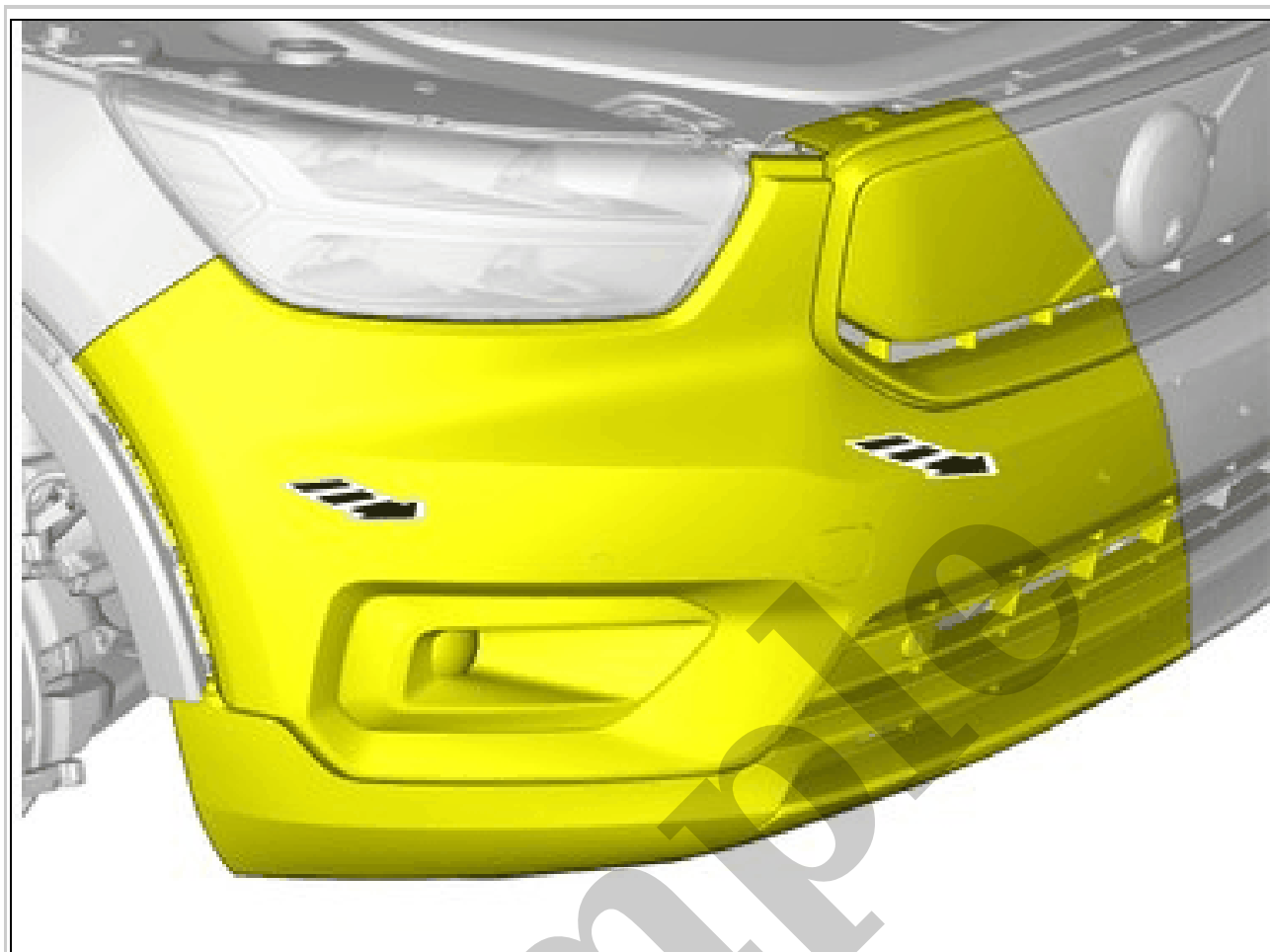

Courtesy of VOLVO CARS CORPORATION

CAUTION: *Make sure not to damage painted surfaces.*

Remove the part carefully
Tilt the component somewhat.

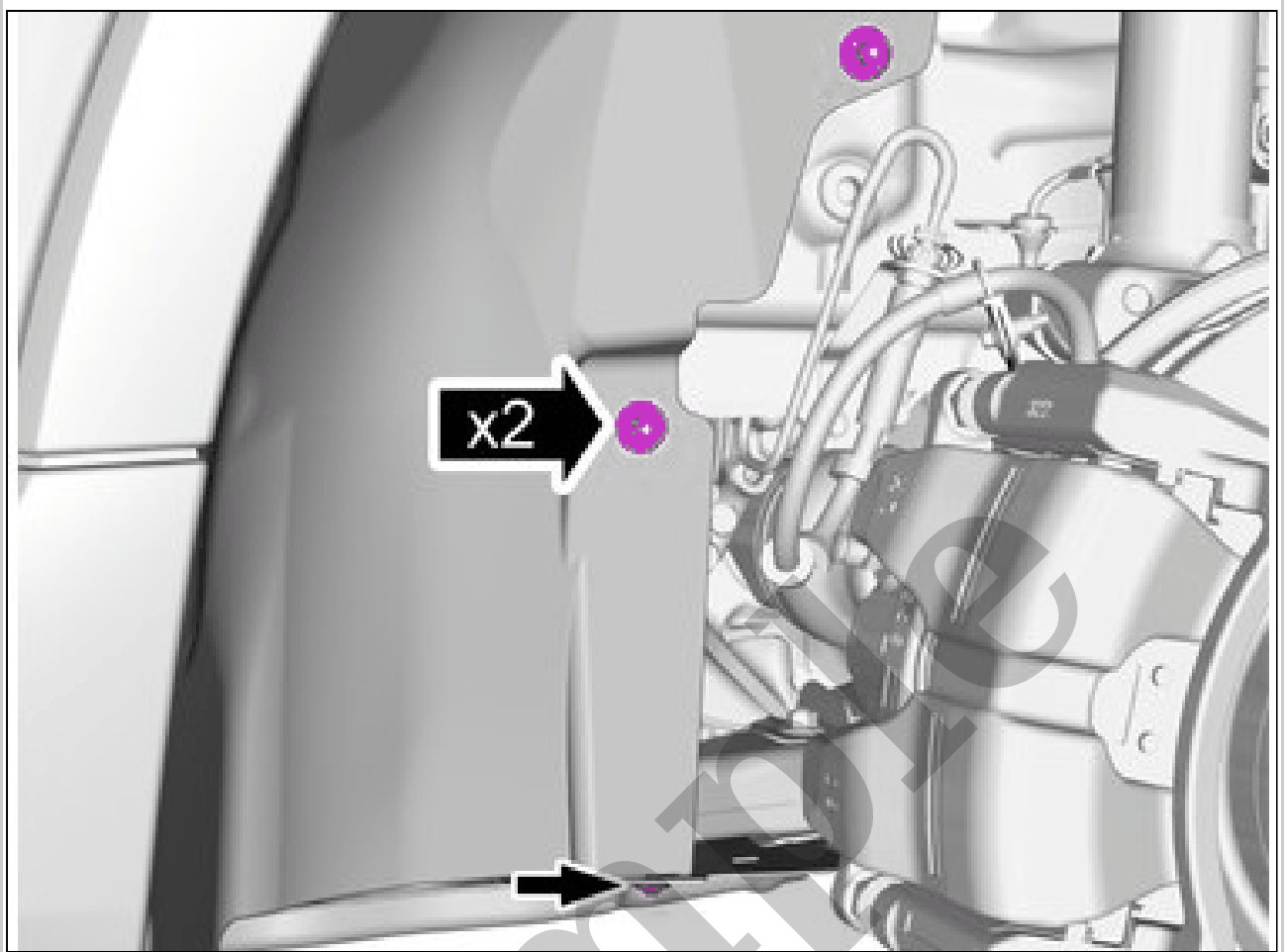

Courtesy of VOLVO CARS CORPORATION

Remove the nuts.
Remove the screw.