

# Your Ultimate Source for OEM Repair Manuals

FactoryManuals.net is a great resource for anyone who wants to save money on repairs by doing their own work. The manuals provide detailed instructions and diagrams that make it easy to understand how to fix a vehicle.

## 2012 VOLVO S40 OEM Service and Repair Workshop Manual

[Go to manual page](#)

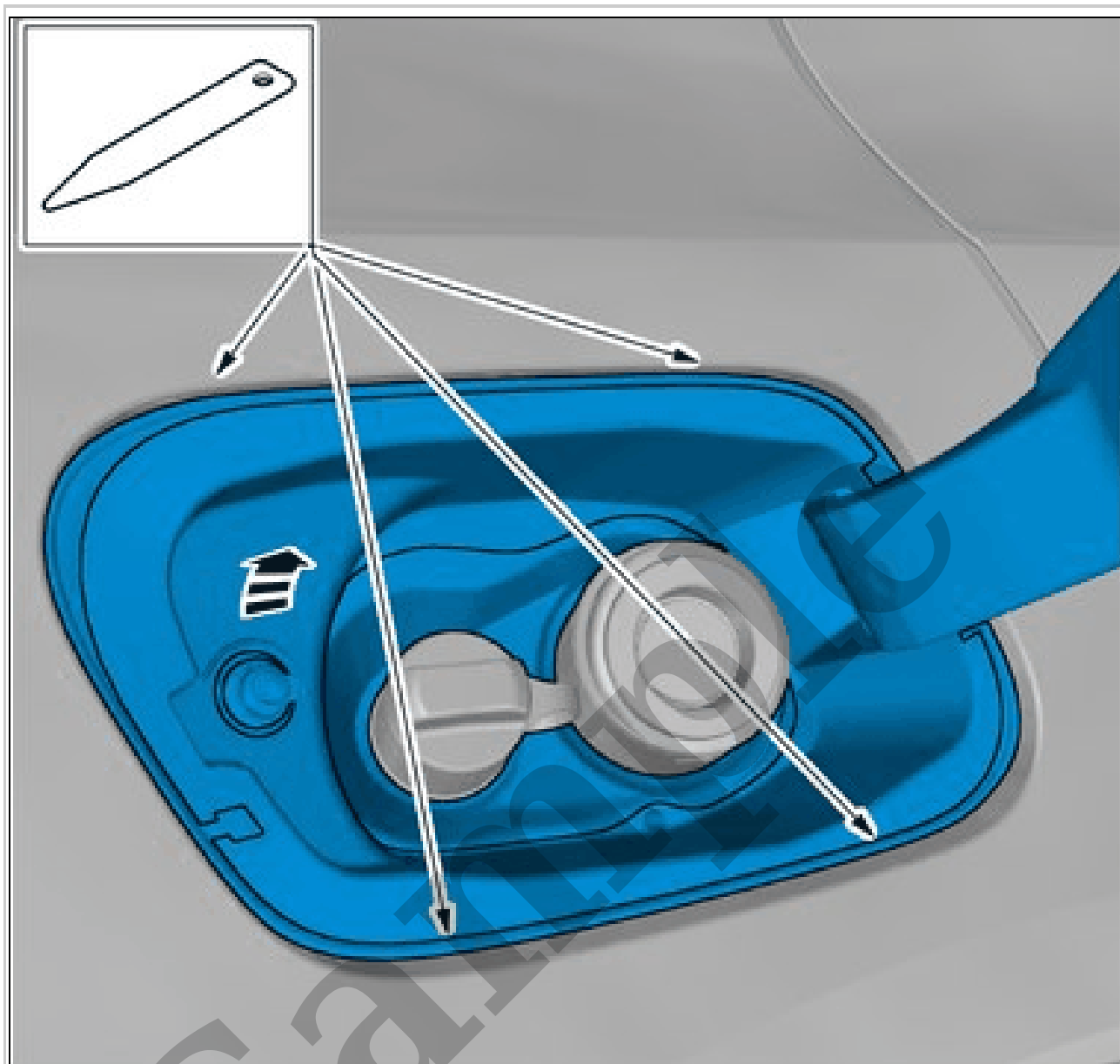

Courtesy of VOLVO CARS CORPORATION

Release the catches.  
Remove the marked part.

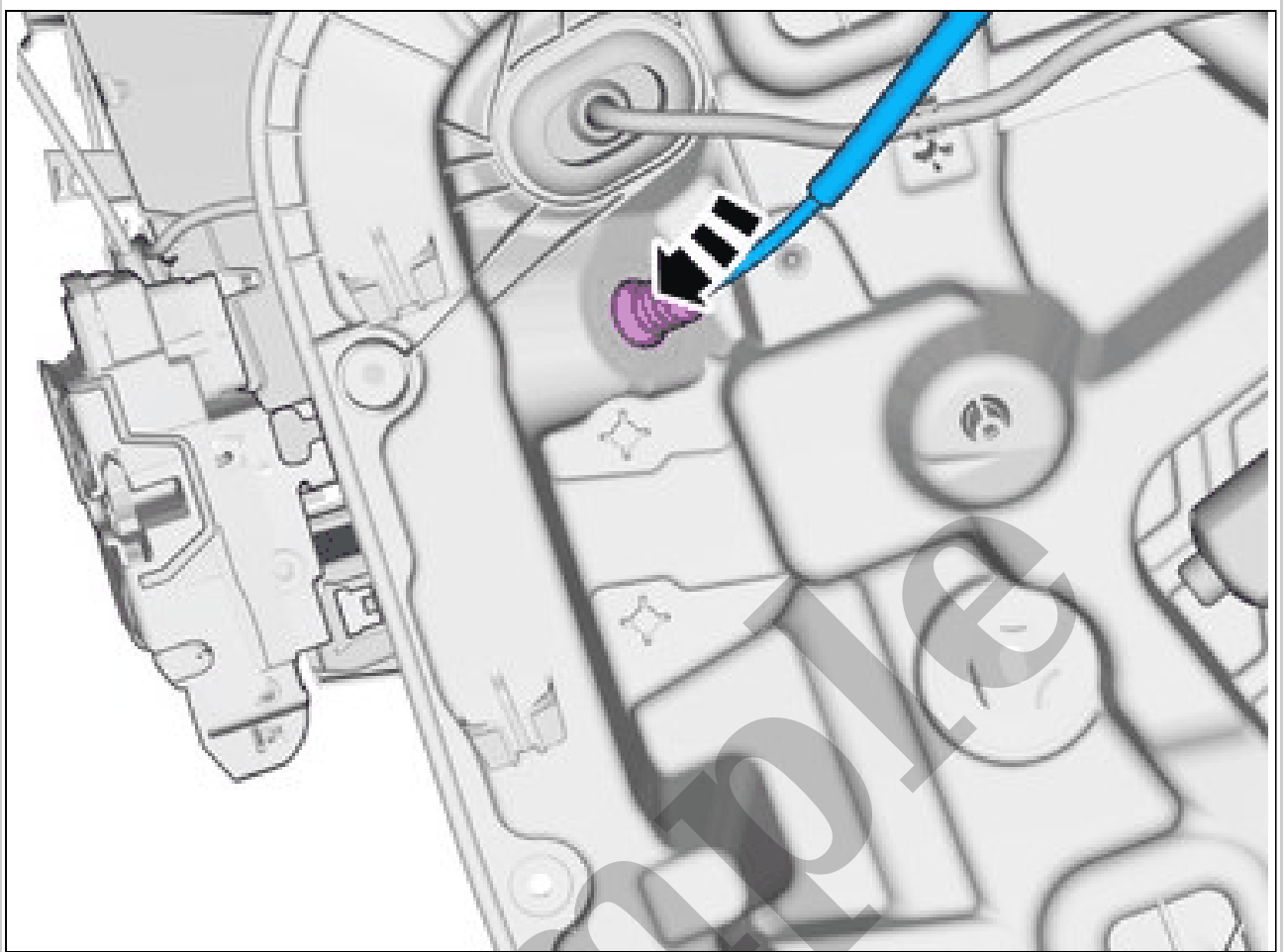

Courtesy of VOLVO CARS CORPORATION

Press the marked component.

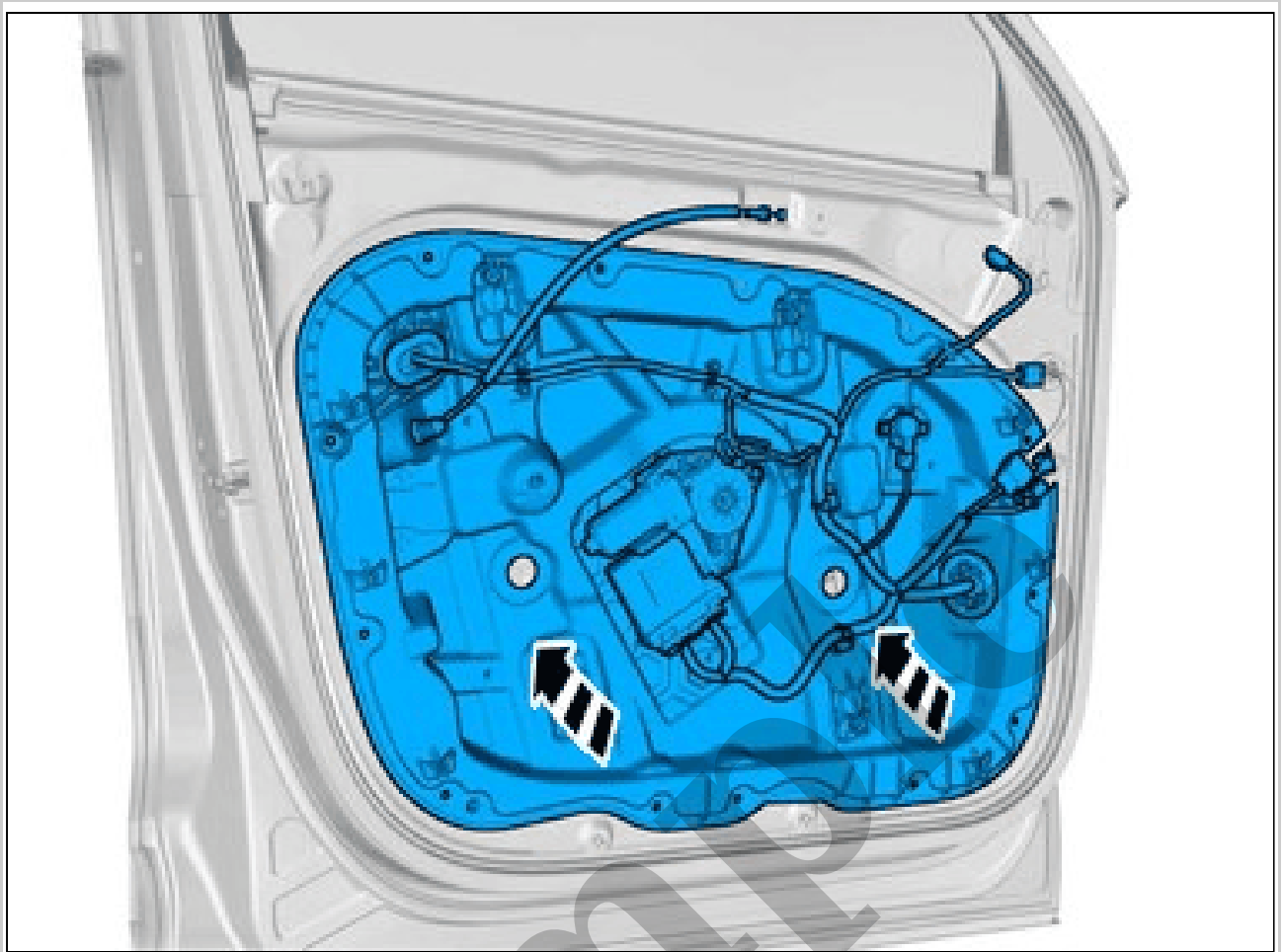

Courtesy of VOLVO CARS CORPORATION

Install the marked component.

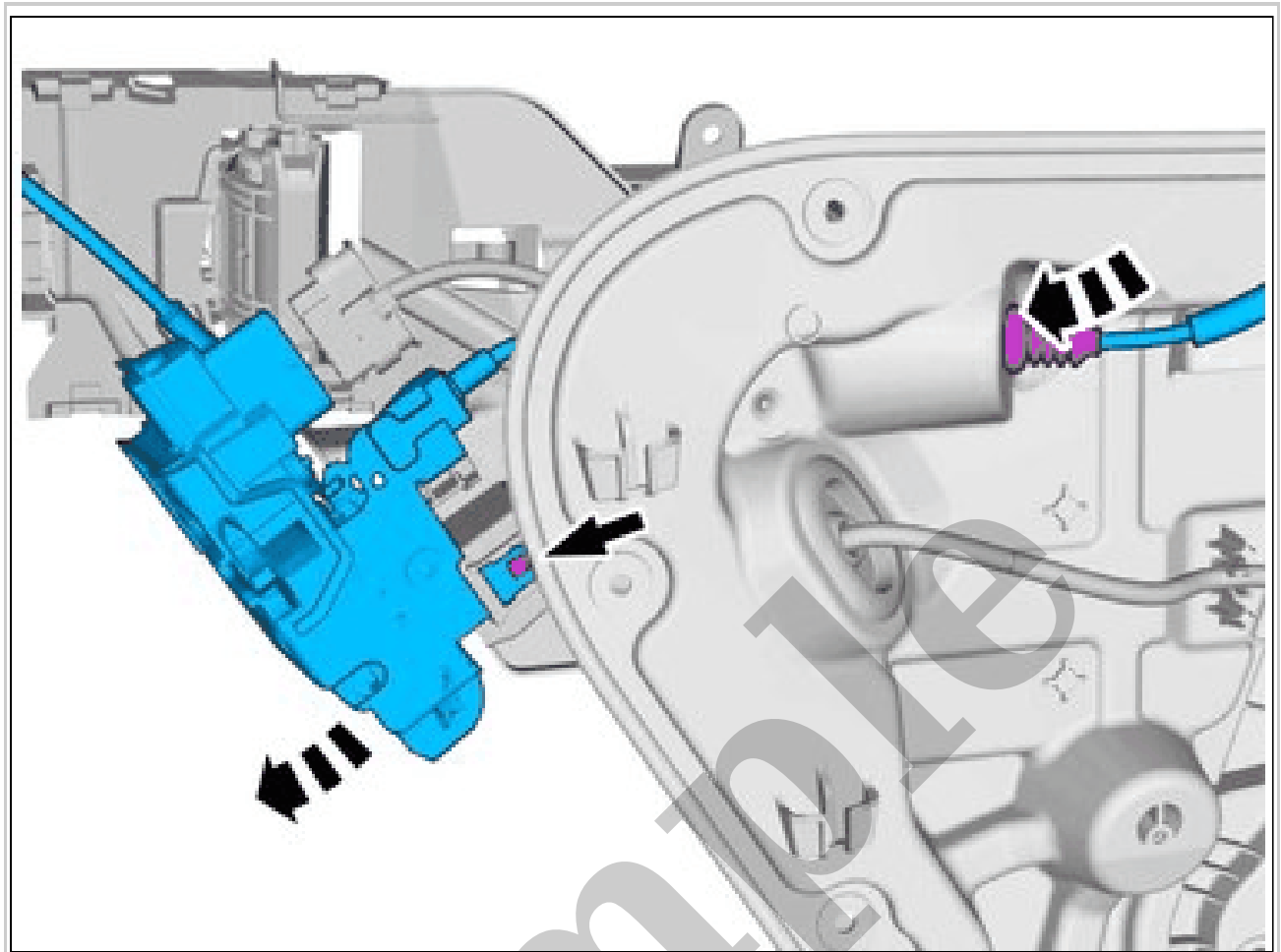

Courtesy of VOLVO CARS CORPORATION

Release the lock.  
Loosen the marked details.

*missing:*

Carry out door latch reinforcement plate, sealing. Refer to: DOOR LATCH REINFORCEMENT PLATE, SEALING

**VEHICLES MANUFACTURED BEFORE 20W47**

Replace console lock mechanism side door rear. Refer to: DOOR LATCH BRACKET, REAR DOOR

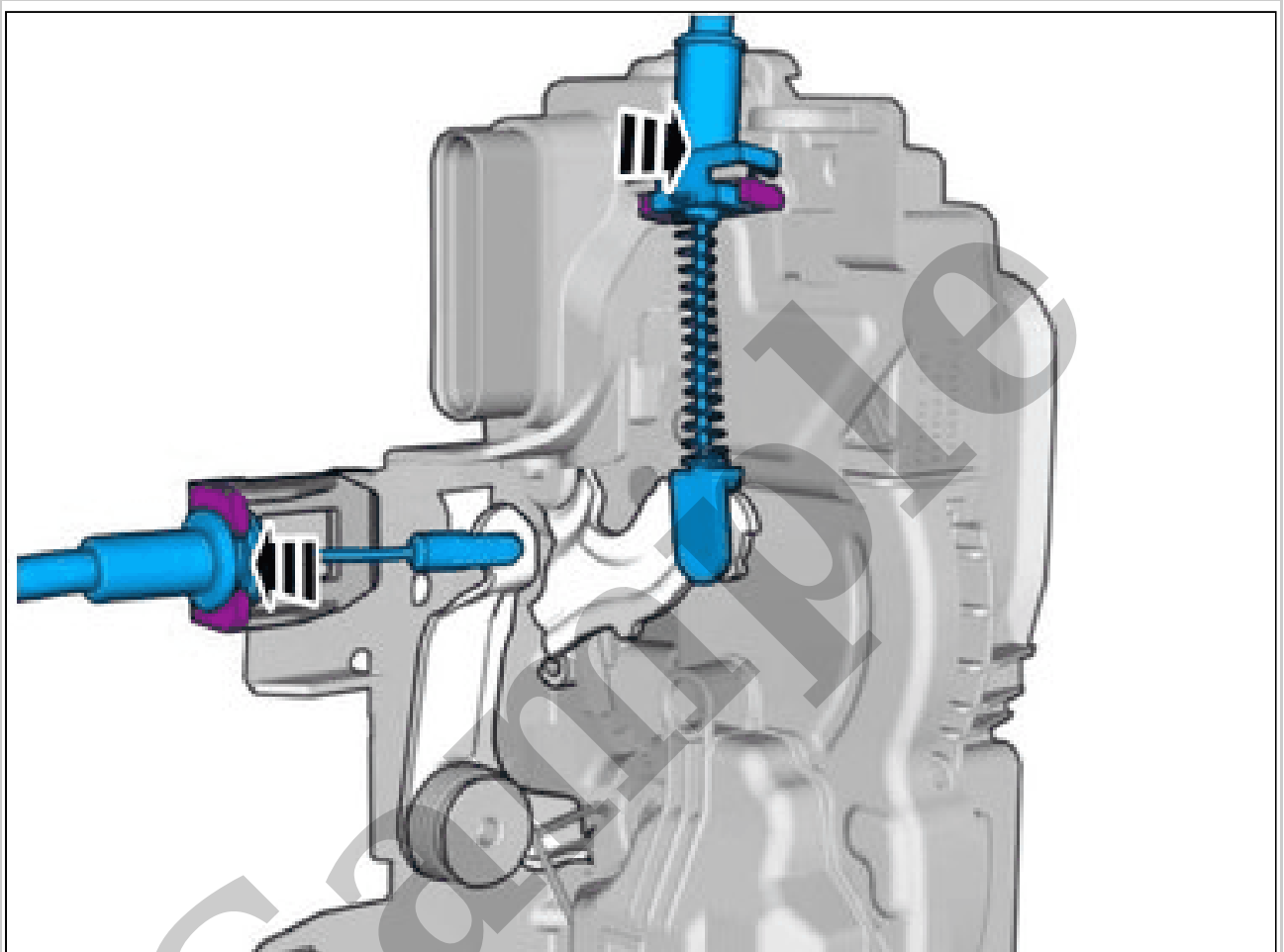

Courtesy of VOLVO CARS CORPORATION

Install the marked components.

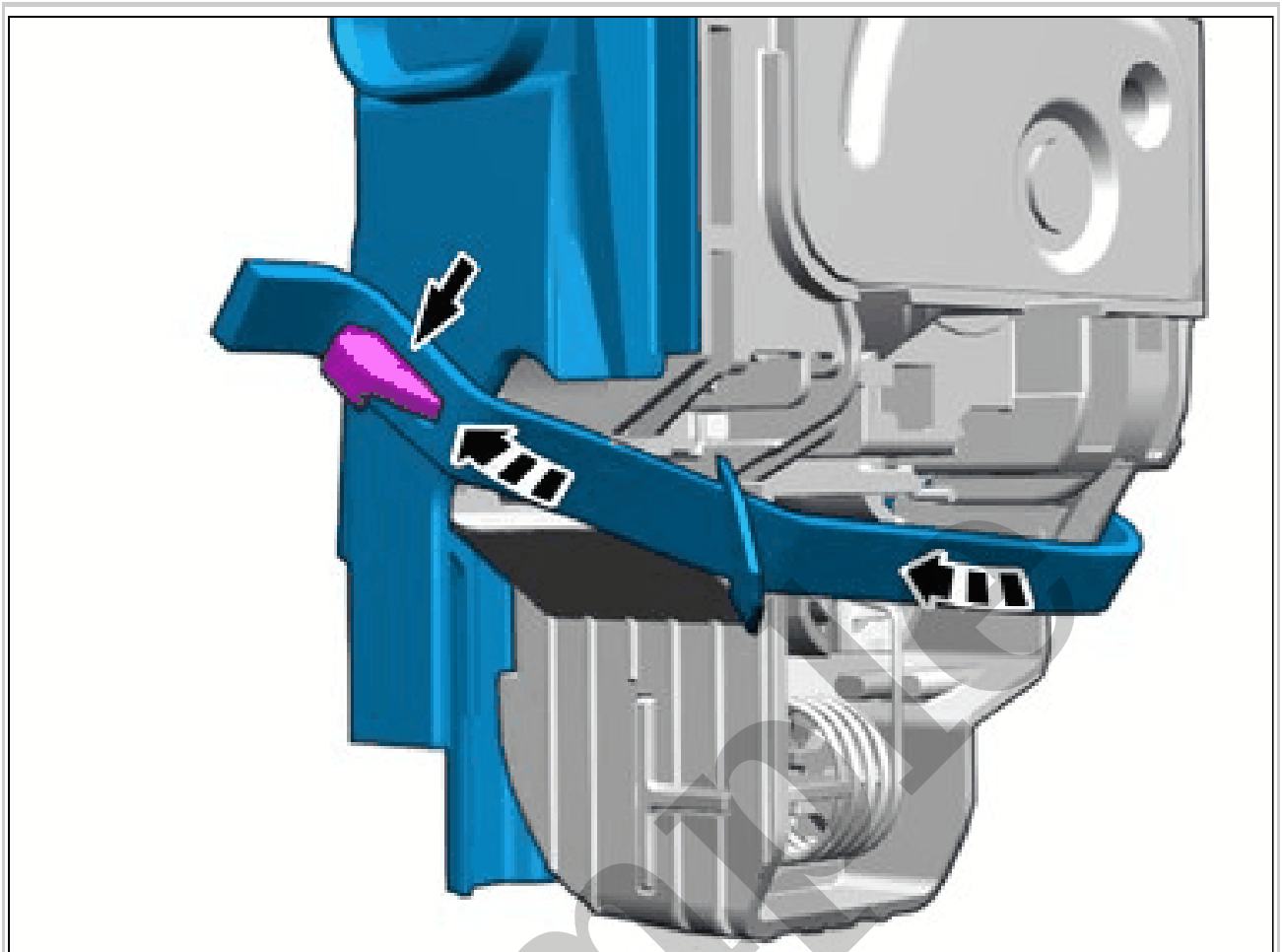

Courtesy of VOLVO CARS CORPORATION

Attach the components with the belt.

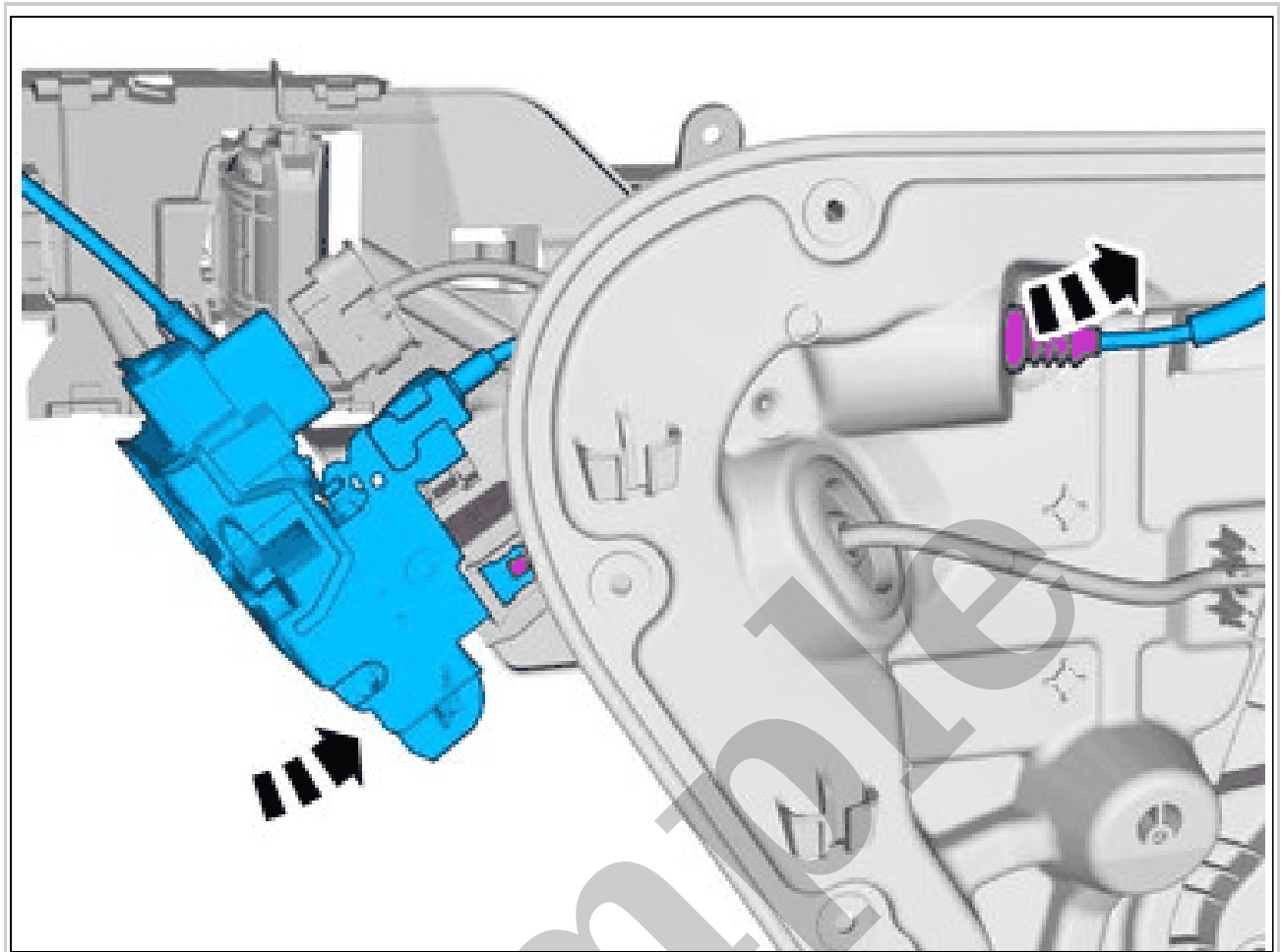

Courtesy of VOLVO CARS CORPORATION

Install the marked component.



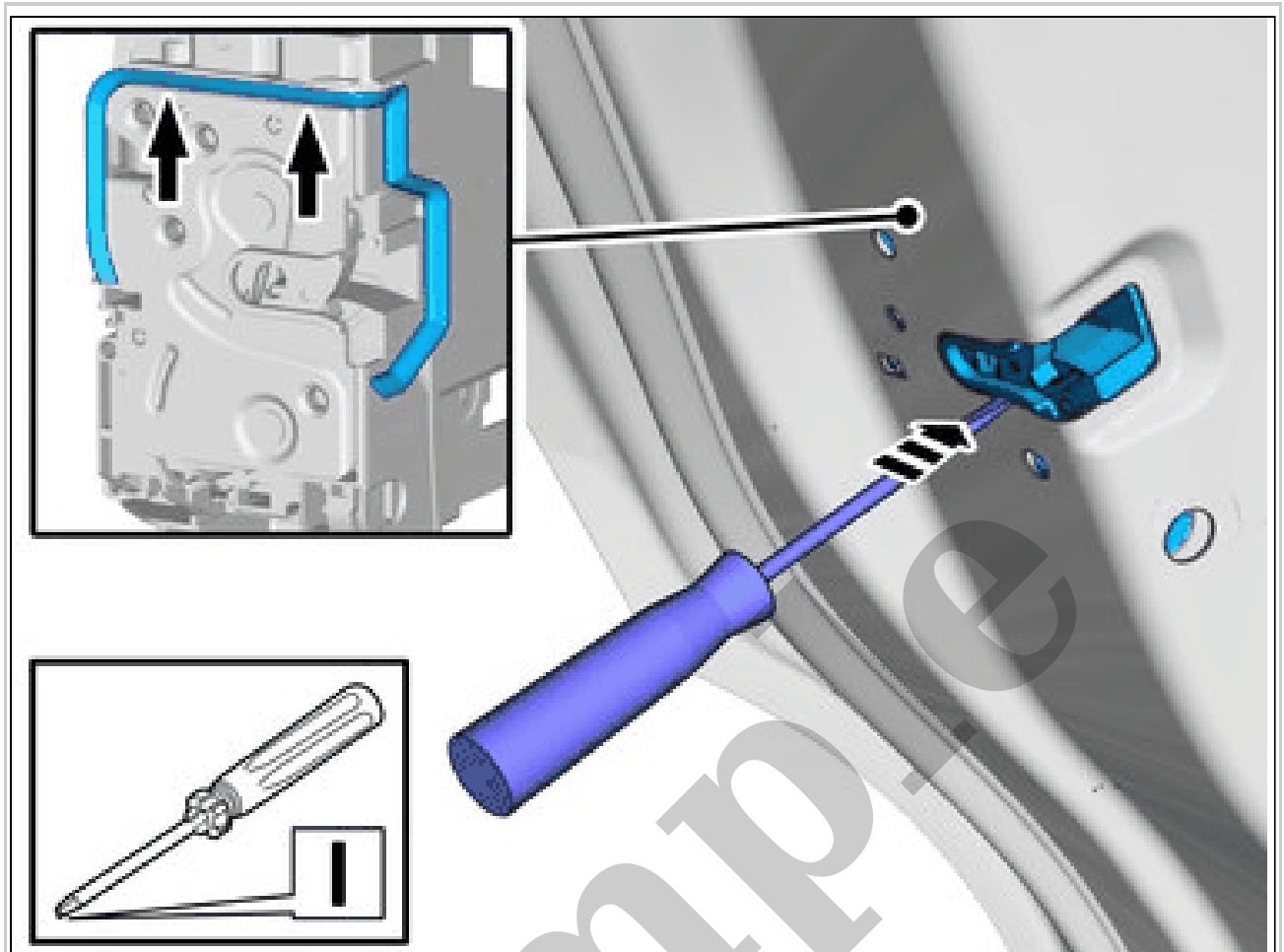

Courtesy of VOLVO CARS CORPORATION

**CAUTION:** *Lightly press the door latch so that the sealing is in the correct position.*



Courtesy of VOLVO CARS CORPORATION

Remove the marked part.