

# Your Ultimate Source for OEM Repair Manuals

FactoryManuals.net is a great resource for anyone who wants to save money on repairs by doing their own work. The manuals provide detailed instructions and diagrams that make it easy to understand how to fix a vehicle.

## 2011 FORD Mustang Shelby GT500 OEM Service and Repair Workshop Manual

[Go to manual page](#)

24. Remove the LH (left-hand) lower B-pillar trim panel.

Refer to: [B-Pillar Trim Panel - SuperCrew](#)(501-05 Interior Trim and Ornamentation, Removal and Installation).

25. Remove the LH (left-hand) C-pillar trim panel.

Refer to: [C-Pillar Trim Panel](#)(501-05 Interior Trim and Ornamentation, Removal and Installation).

26. Fold the carpet rearward.

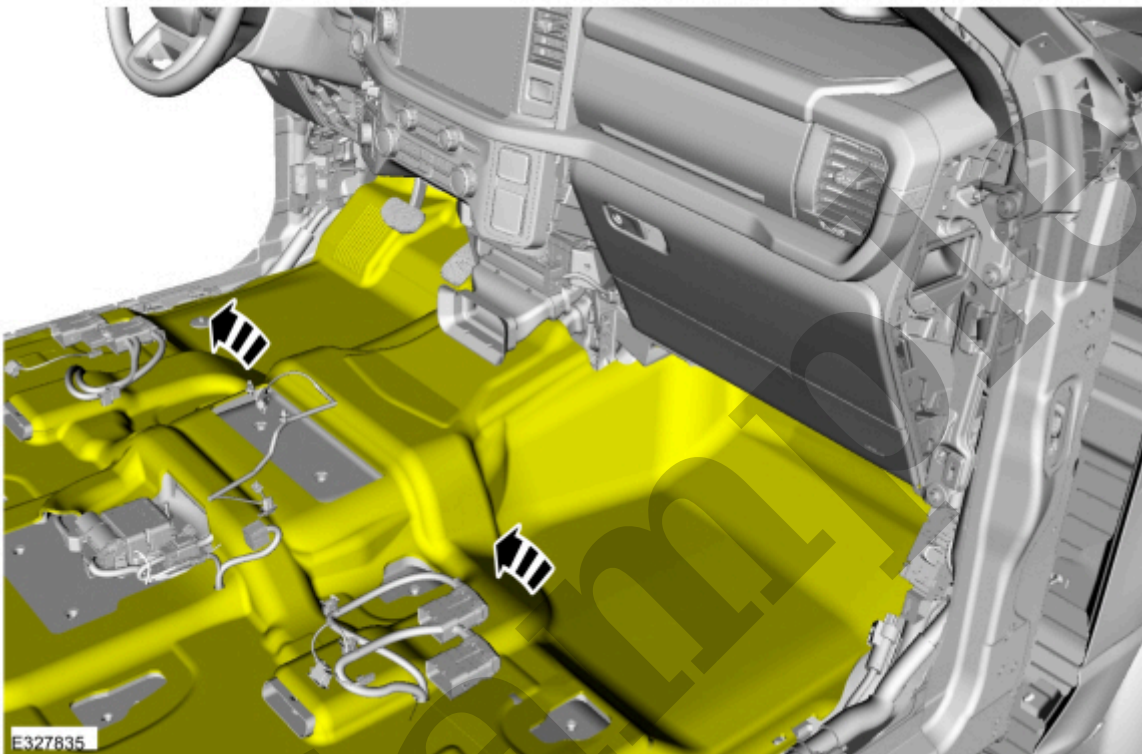

[Click here to learn about symbols, color coding, and icons used in this manual.](#)

27. Remove the push pins and the HVAC (heating, ventilation and air conditioning) floor duct.

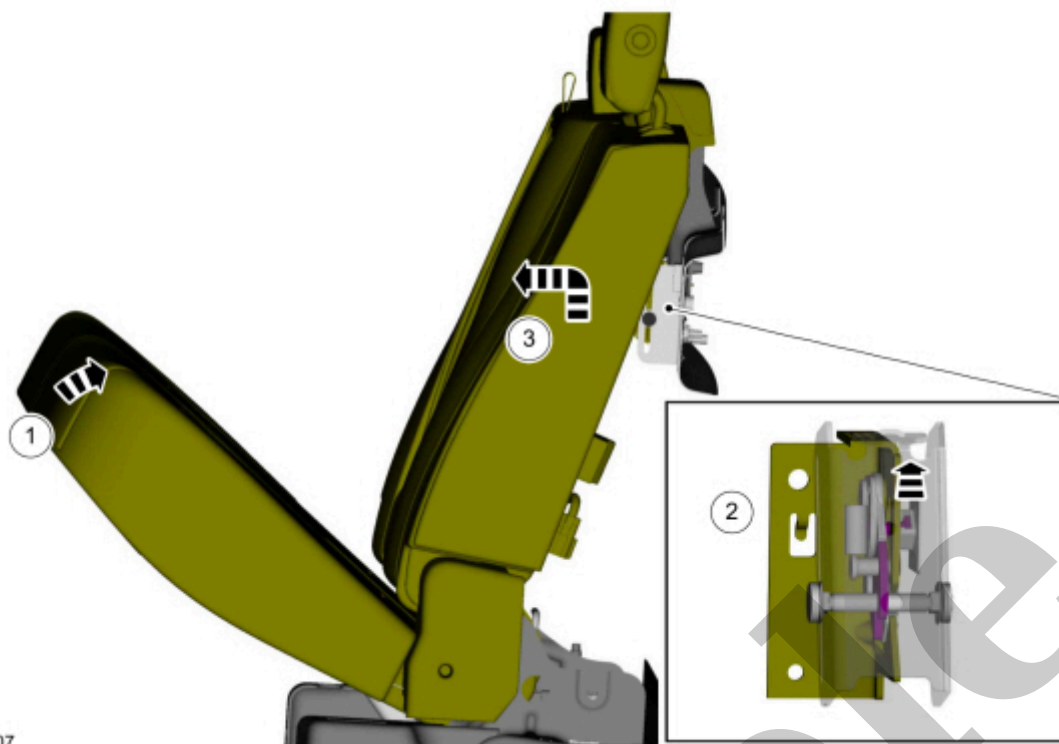

E195107

[Click here to learn about symbols, color coding, and icons used in this manual.](#)

29. Disconnect the body harness AAB (automotive audio bus) front connector.

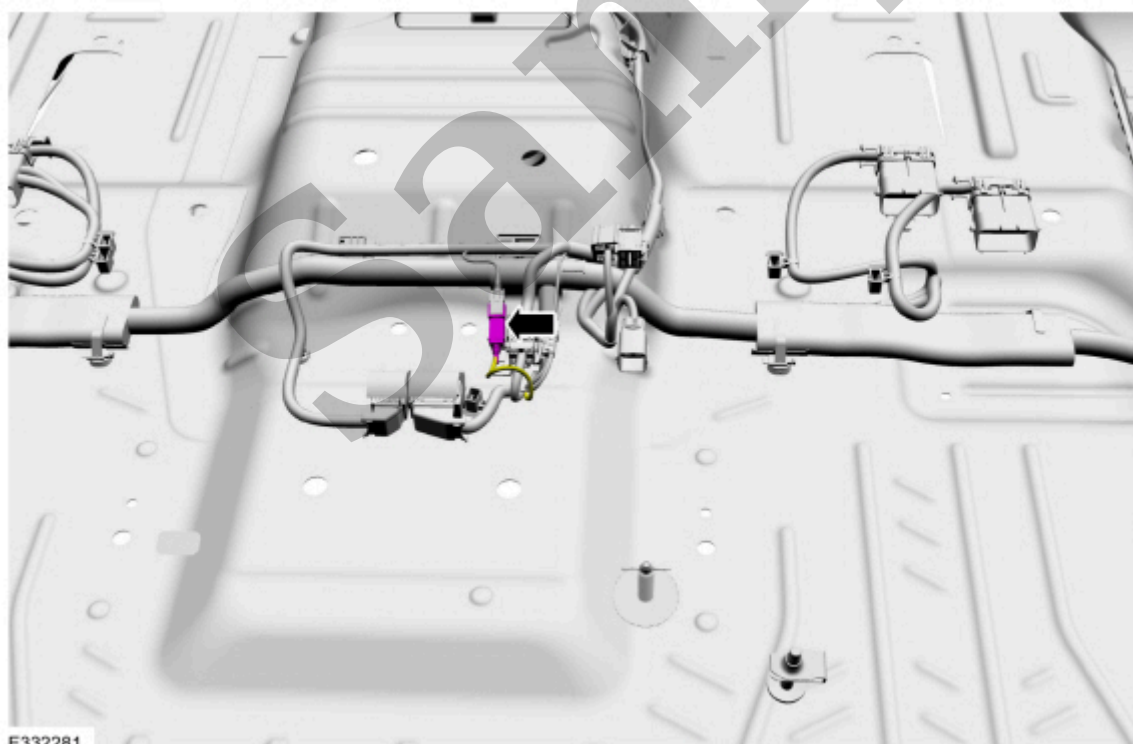

E332281

[Click here to learn about symbols, color coding, and icons used in this manual.](#)

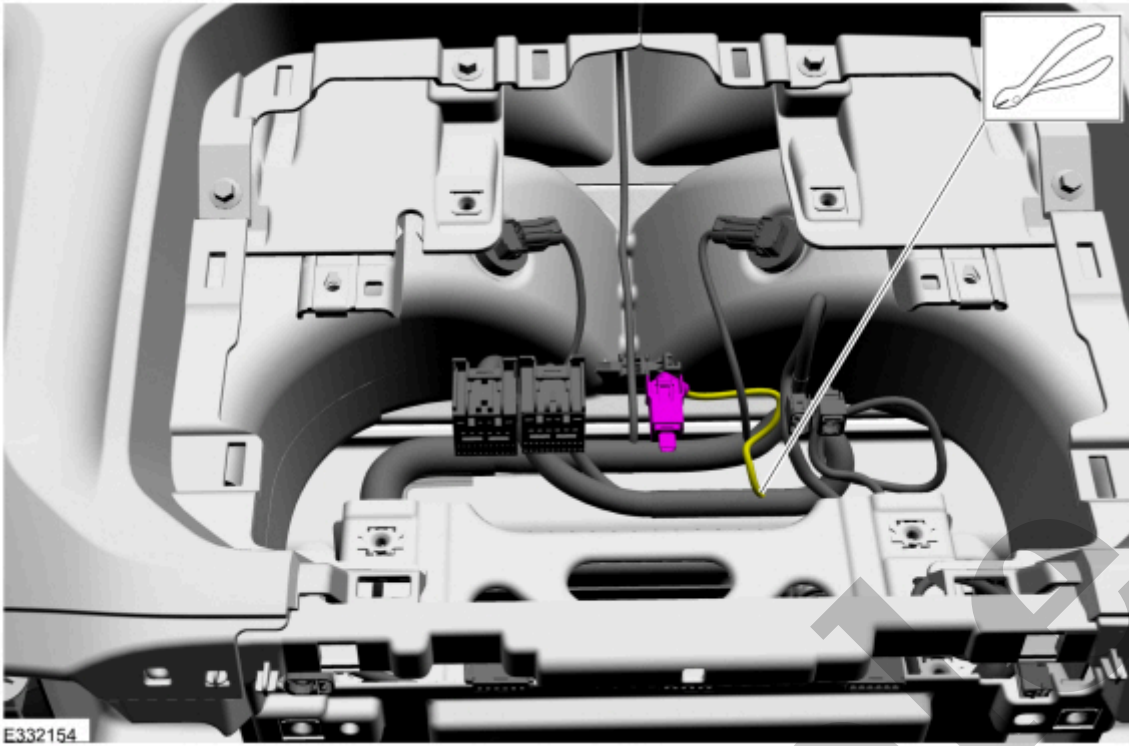

[Click here to learn about symbols, color coding, and icons used in this manual.](#)

2. Cut the lower connector end off the cable where it enters the instrument panel harness.

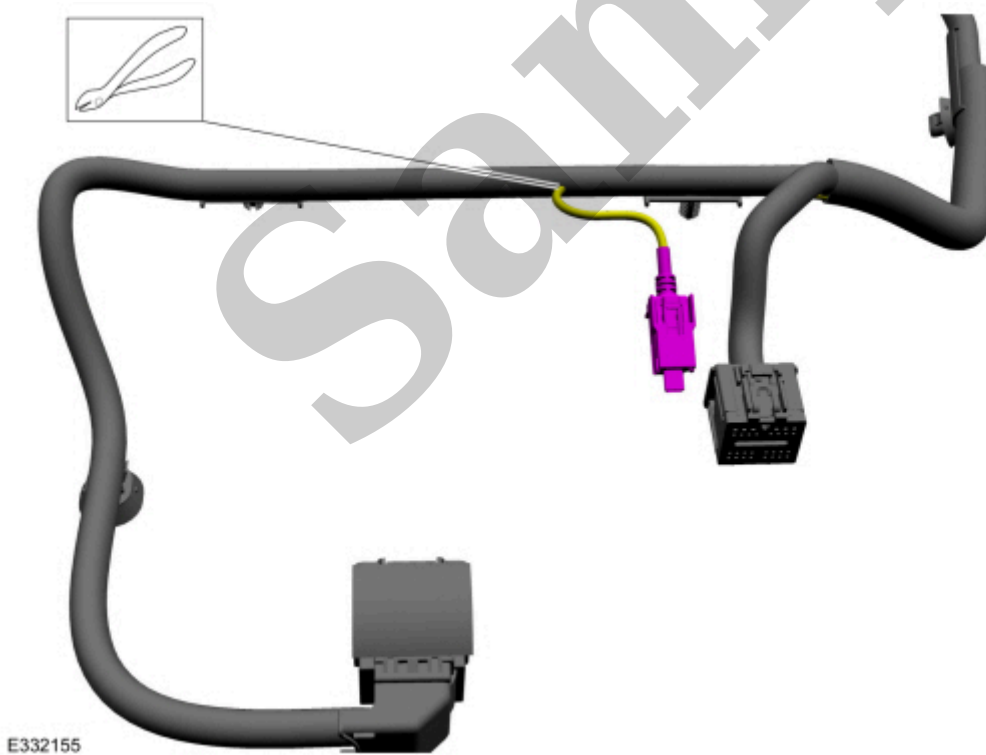

[Click here to learn about symbols, color coding, and icons used in this manual.](#)

3. Install the new AAB (automotive audio bus) cable.

[Click here to learn about symbols, color coding, and icons used in this manual.](#)

### Body harness automotive audio bus cable - Supercab vehicles

4. Cut the front connector end off the cable where it enters the body harness.

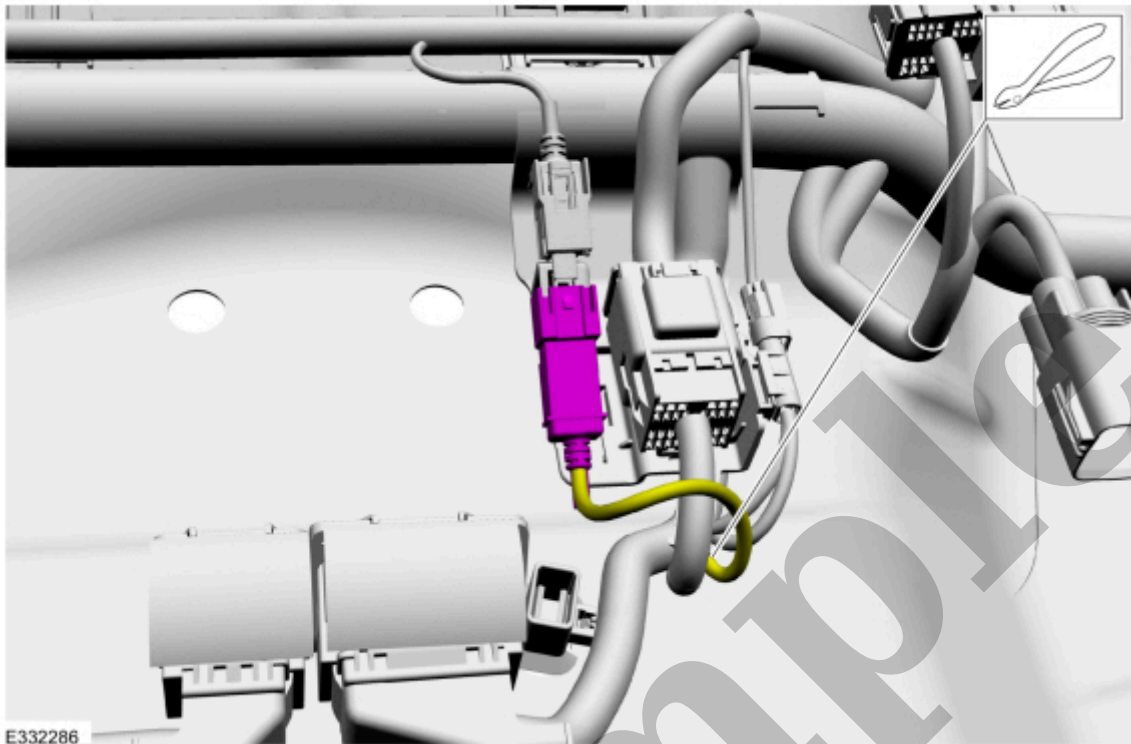

[Click here to learn about symbols, color coding, and icons used in this manual.](#)

#### 5. NOTE

Eight speaker system DSP (audio digital signal processing module) is shown, 18 speaker system DSP (audio digital signal processing module) is similar.

Cut the rear connector end off the cable where it enters the body harness.

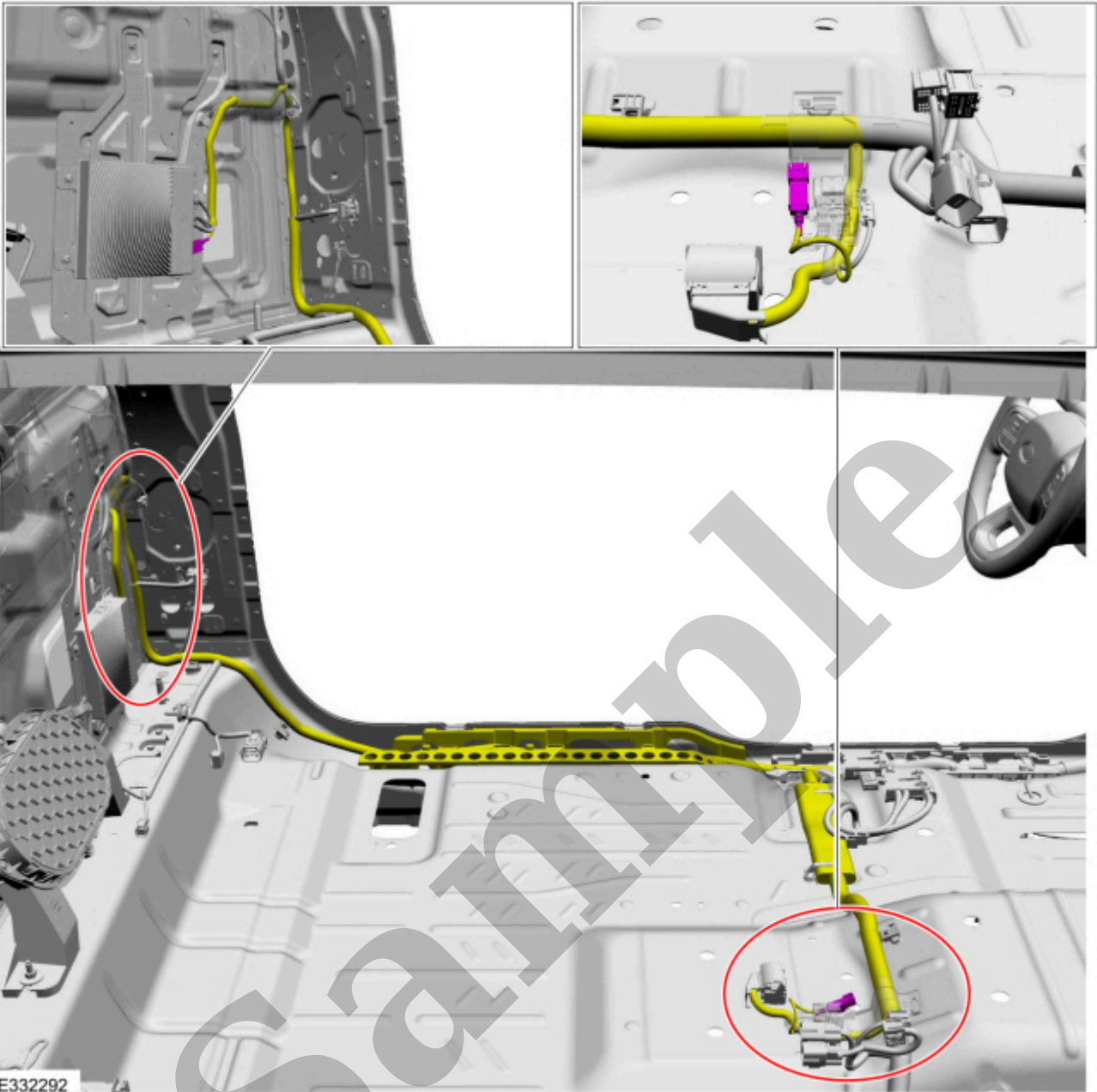

[Click here to learn about symbols, color coding, and icons used in this manual.](#)

### **Body harness automotive audio bus cable - Supercrew vehicles**

7. Cut the front connector end off the cable where it enters the body harness.

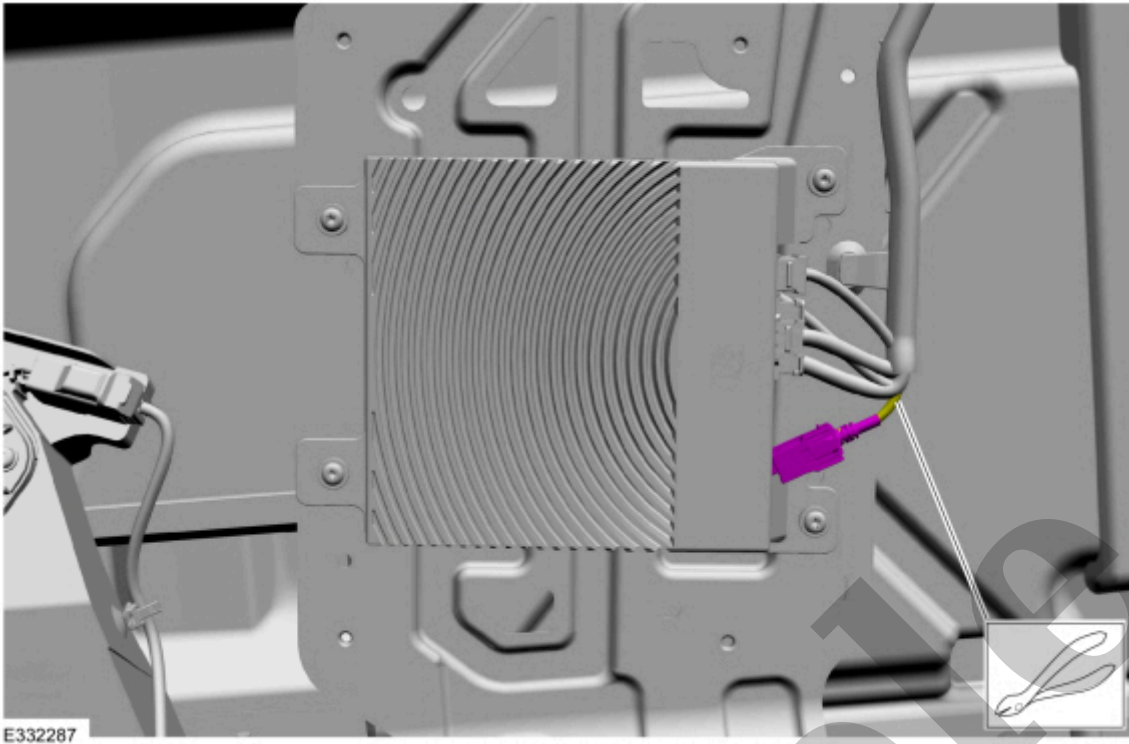

[Click here to learn about symbols, color coding, and icons used in this manual.](#)

9. Install the new AAB (automotive audio bus) cable.

- Route the new body harness AAB (automotive audio bus) cable following the routing shown.
- Secure the new body harness AAB (automotive audio bus) cable, as necessary, to prevent NVH (noise, vibration and harshness) concerns.

## Automotive Audio Bus (AAB) Cable - Vehicles With: 8 Inch Center Display Screen/12 Inch Center Display Screen

<b>415-00 Information and Entertainment System - General Information</b>	<b>2022 F-150</b>
<b>Removal and Installation</b>	<b>Procedure revision date: 03/29/2022</b>

### Automotive Audio Bus (AAB) Cable - Vehicles With: 8 Inch Center Display Screen/12 Inch Center Display Screen

#### Removal

##### NOTE

Removal steps in this procedure may contain installation details.

##### NOTE

The original equipment automotive audio bus (AAB) cables are part of the wiring harnesses and cannot be removed. This procedure refers to replacement of the cable only by overlaying the cable.

#### Instrument panel automotive audio bus cable

1. Remove the instrument panel.

Refer to: [Instrument Panel](#)(501-12 Instrument Panel and Console, Removal and Installation).

2. Remove the ACM (audio front control module) .

Refer to: [Audio Front Control Module \(ACM\) - Vehicles With: 8 Inch Center Display Screen/12 Inch Center Display Screen](#)(415-00 Information and Entertainment System - General Information, Removal and Installation).



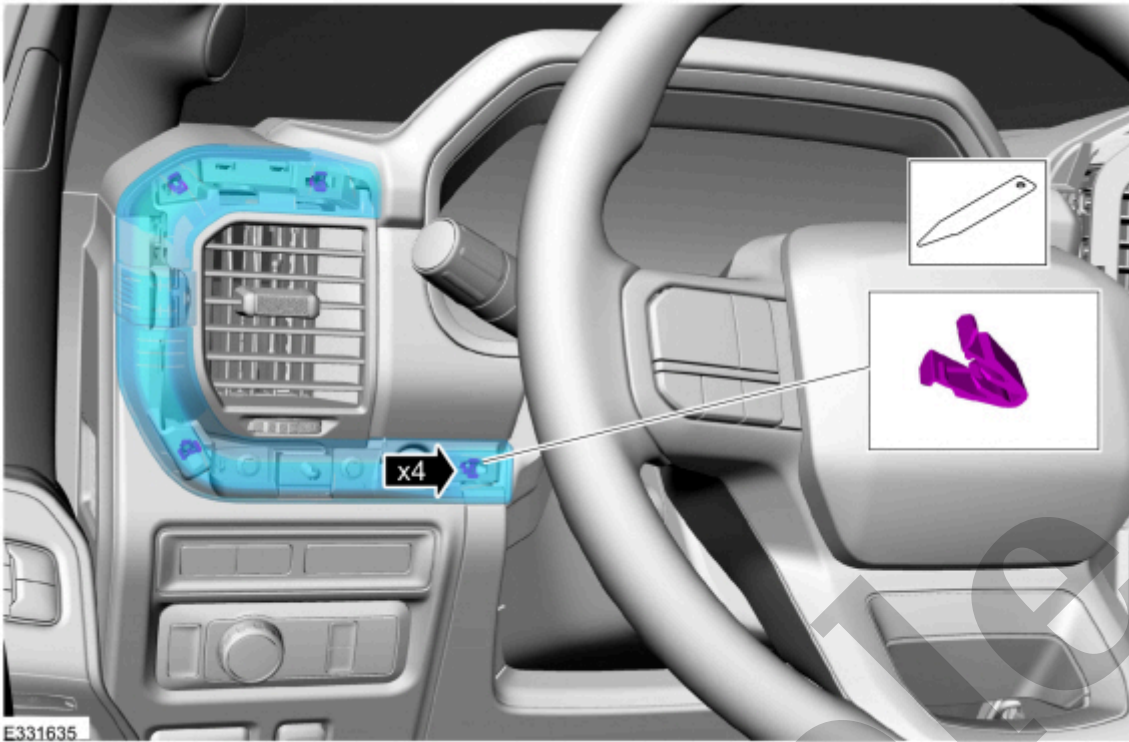

[Click here to learn about symbols, color coding, and icons used in this manual.](#)

5. Remove the steering column opening lower trim panel.

1. Unclip and lower the steering column opening lower trim panel.

2. Remove the retainers and the steering column opening lower trim panel.

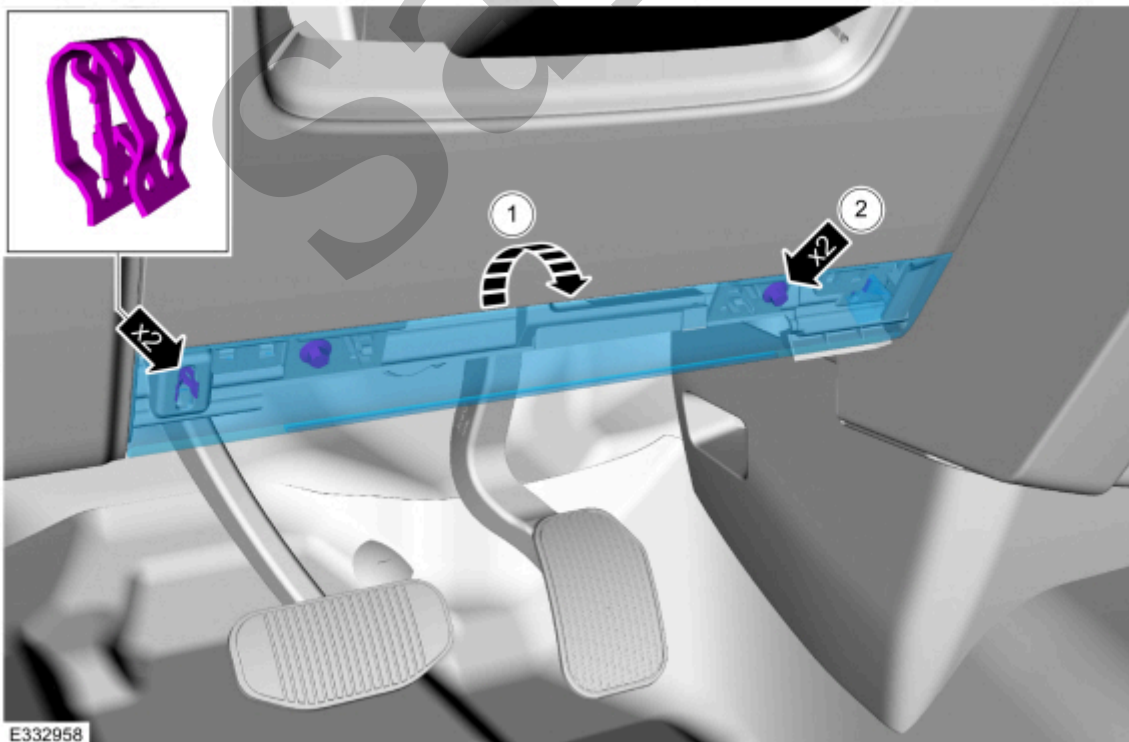

[Click here to learn about symbols, color coding, and icons used in this manual.](#)

8. Release the tabs and disconnect the gap hider from the upper steering column shroud.

Use the General Equipment: Interior Trim Remover

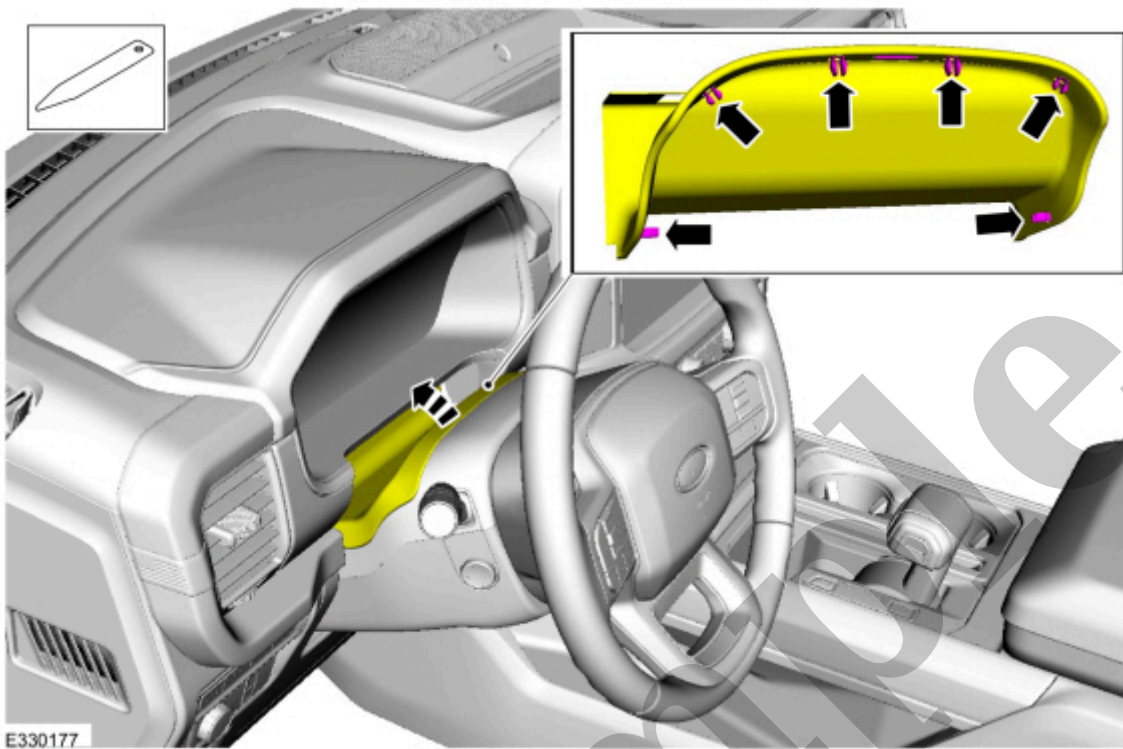

[Click here to learn about symbols, color coding, and icons used in this manual.](#)

9. Remove the screws.

**Torque** : 22 lb.in (2.5 Nm)