

Your Ultimate Source for OEM Repair Manuals

FactoryManuals.net is a great resource for anyone who wants to save money on repairs by doing their own work. The manuals provide detailed instructions and diagrams that make it easy to understand how to fix a vehicle.

2009 VOLVO S80 OEM Service and Repair Workshop Manual

[Go to manual page](#)

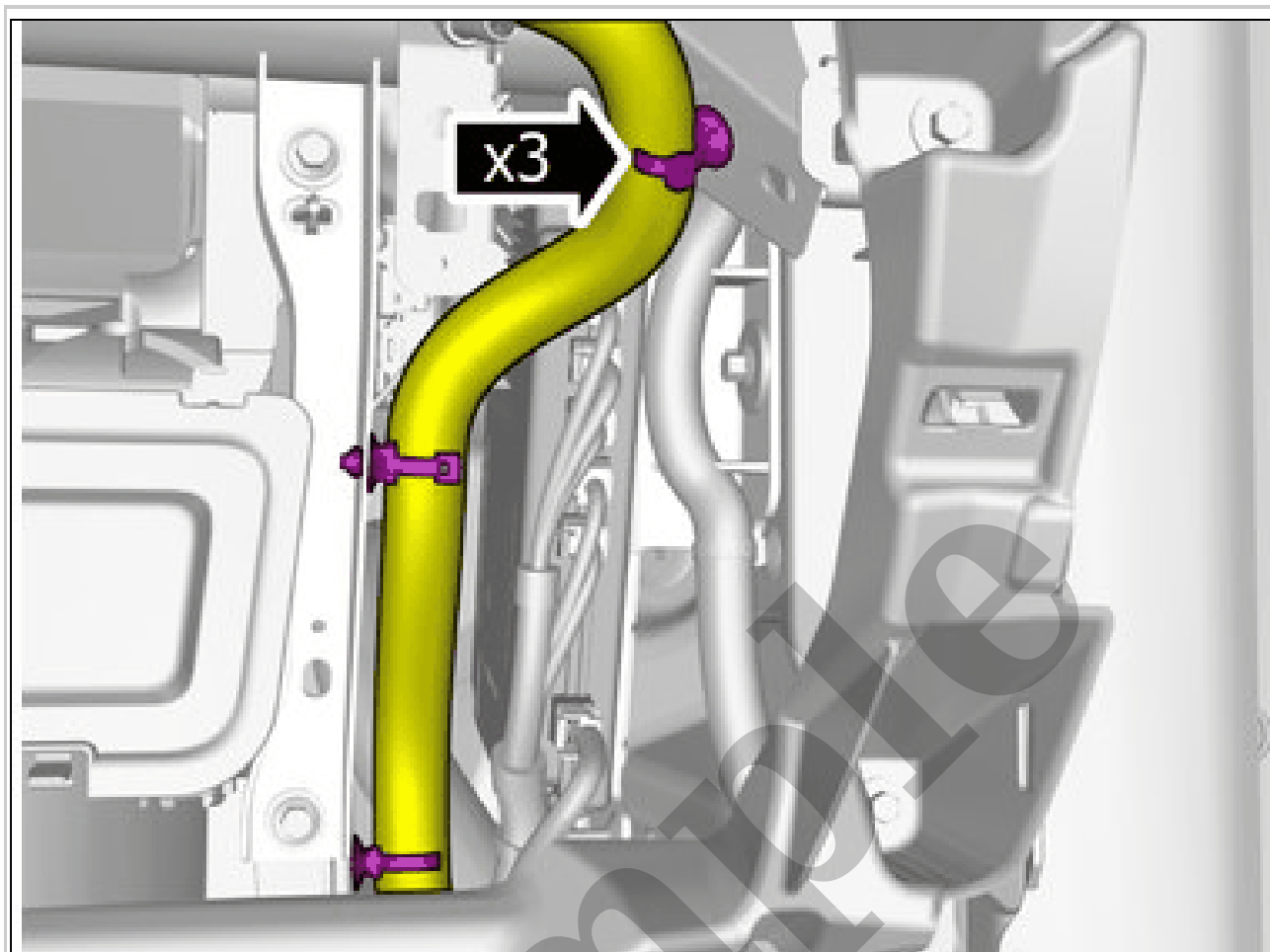

Courtesy of VOLVO CARS CORPORATION

Loosen the clips.
Fold marked part aside.

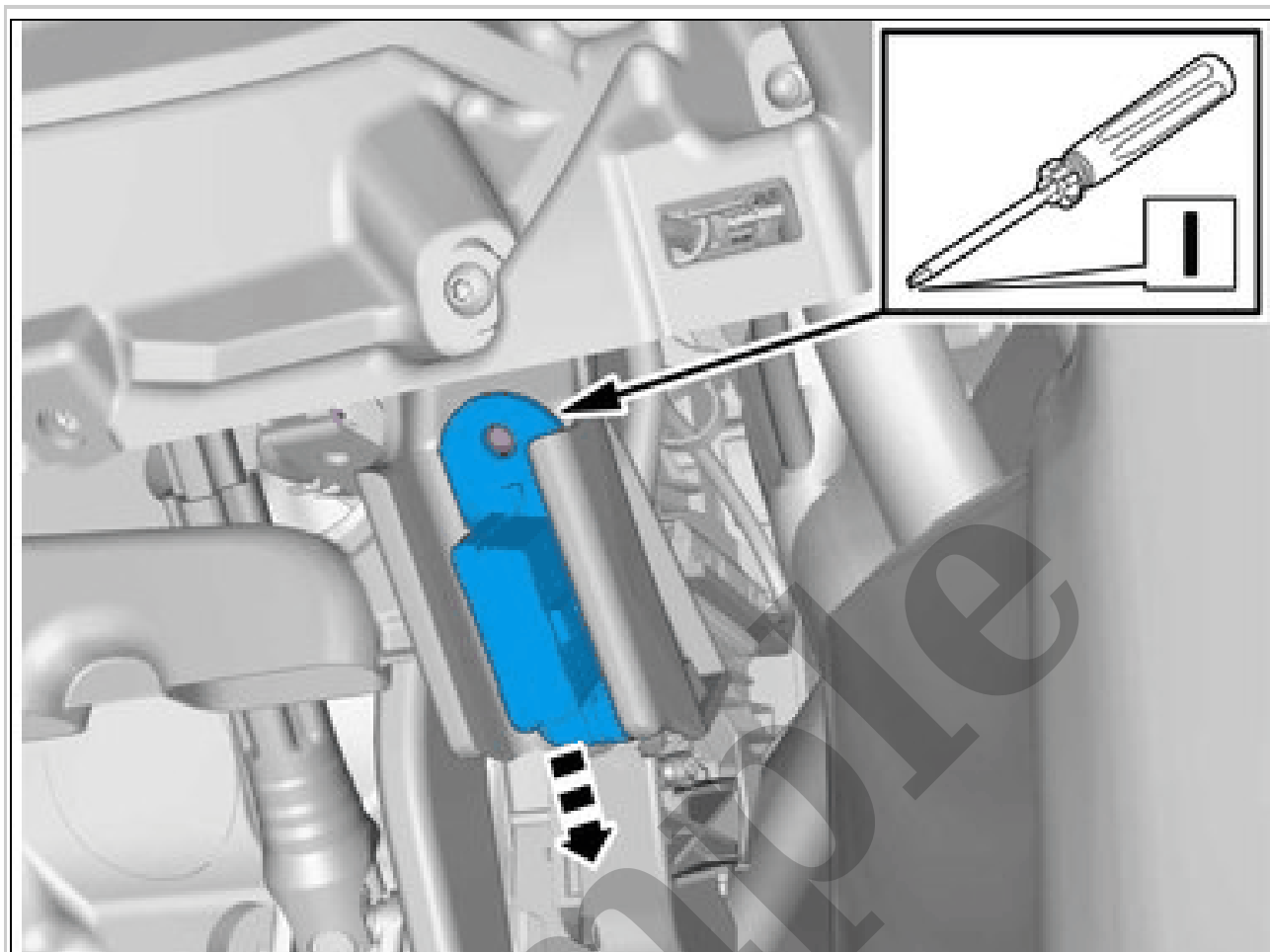

Courtesy of VOLVO CARS CORPORATION

Remove the marked part.

Use: Electrician's screwdriver

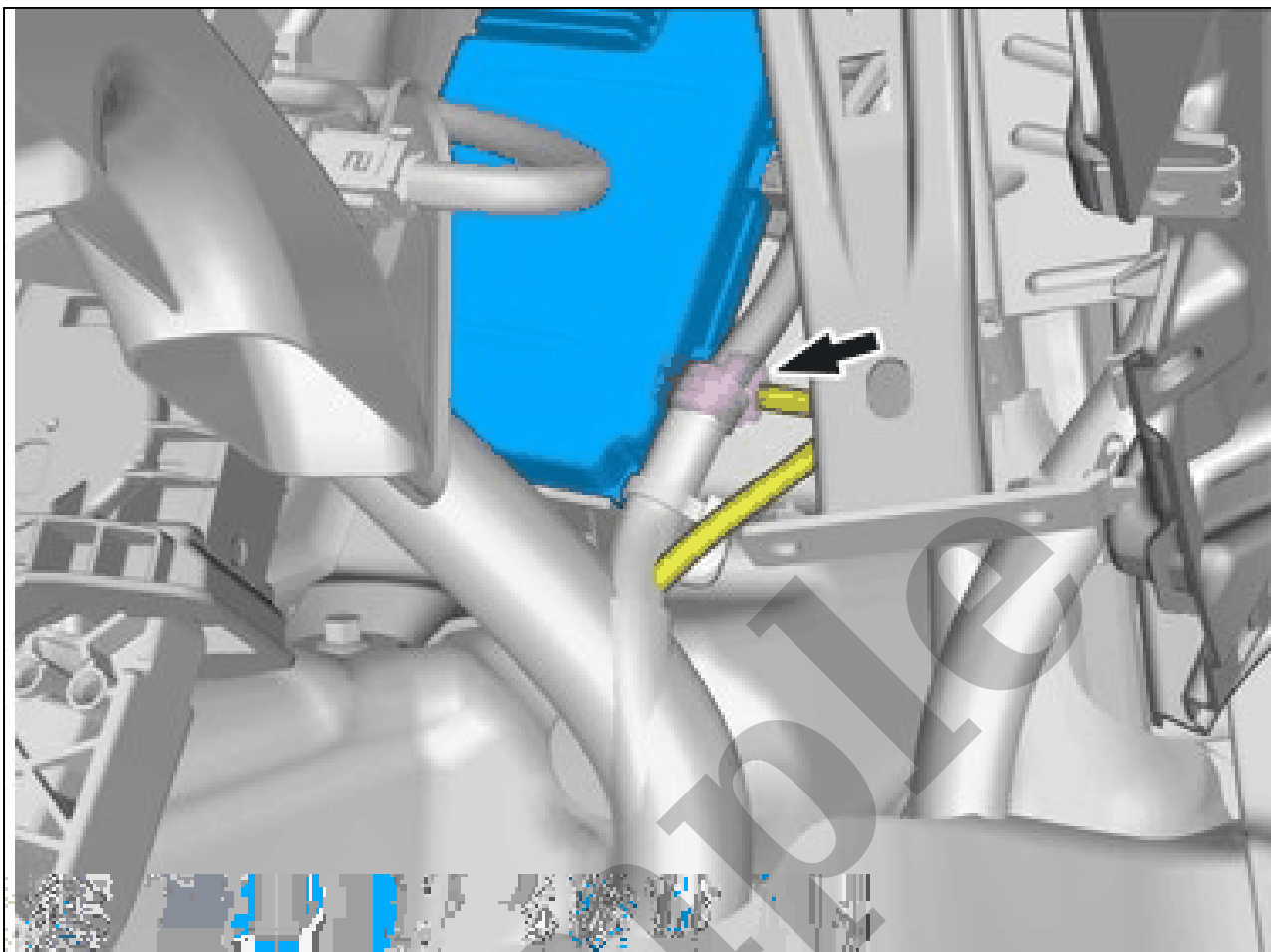

Courtesy of VOLVO CARS CORPORATION

View from below
Disconnect the connector.
VEHICLES EARLY VERSION

OBDFIREWALLMODULE > OBDFIREWALLMODULE (OFM) [2018-2020] > REMOVAL

Remove front seat. Refer to: FRONT SEAT

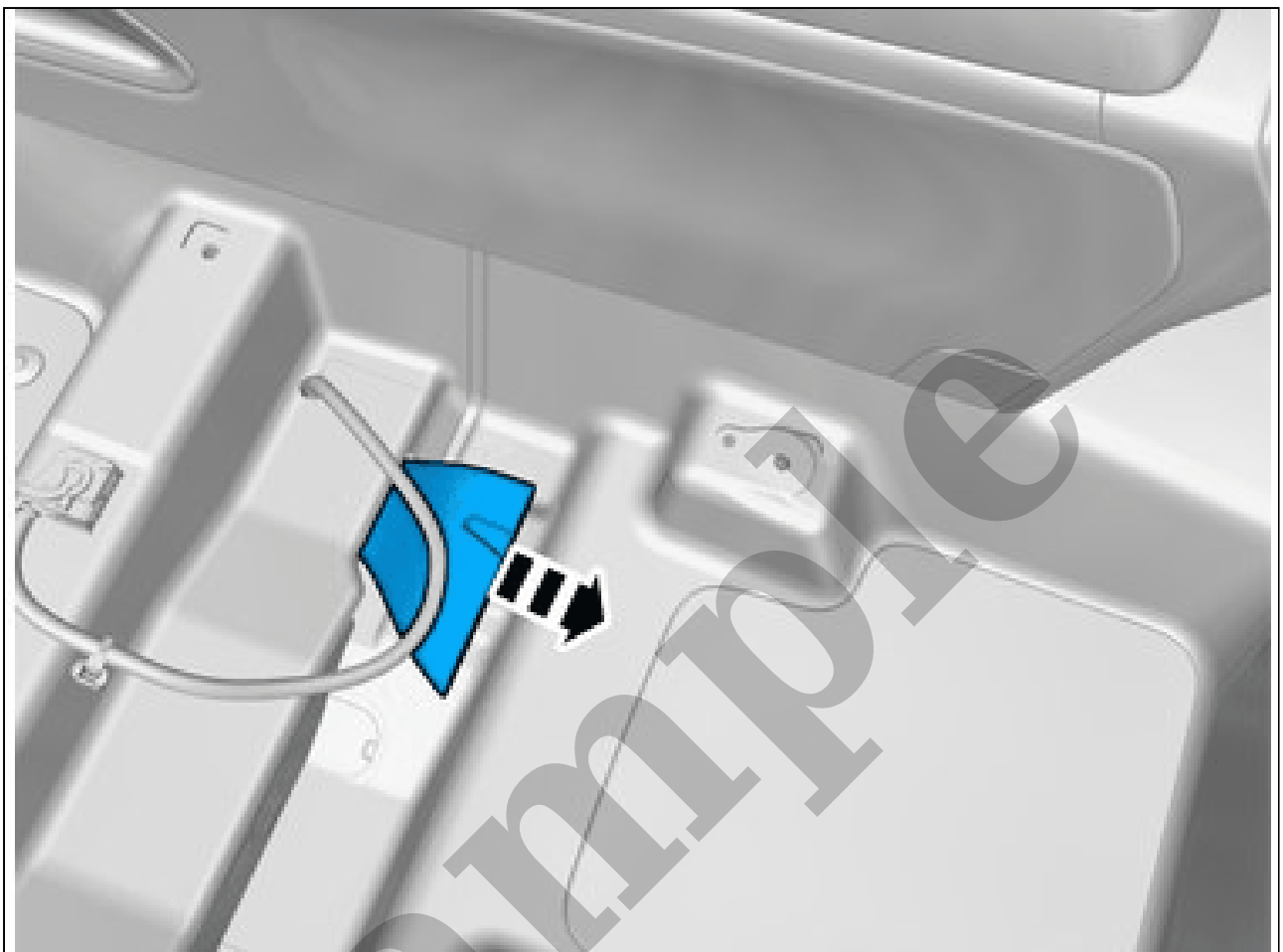

Courtesy of VOLVO CARS CORPORATION

Remove the marked part.

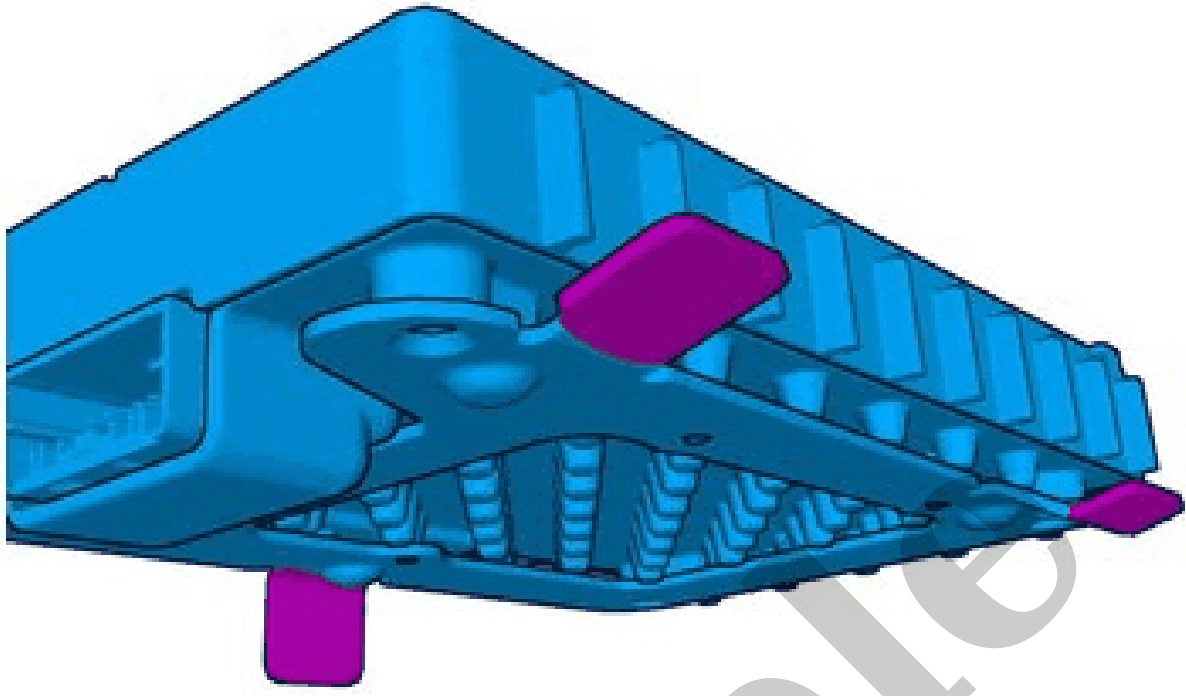

Courtesy of VOLVO CARS CORPORATION

CAUTION: *Ensure that ventilation is good.*

NOTE: *Mask the basecoated area (where PUR adhesive is to be applied) before next layer of paint.*

NOTE: *If any part of the windshield frame has been painted, glass primer must be applied to the body flange.*

NOTE: *When bonding using 2-component adhesive, the windshield must be positioned within 8 minutes.*

Apply adhesive to either the glass or to the body flange.

Hold the gun at right angles to the surface.

Ensure that the adhesive bead is continuous, a break in the adhesive bead can result in the adhesive join surface not being watertight.

Position the glass.

Check that the windshield is in the same position at both A-posts.

Place a few strips of masking tape on the glass and part way over the roof to prevent the glass from sliding down.

WINDSCREEN, REPAIR > WINDSCREEN, REPAIR [2018-2022] > GENERAL INFORMATION

WARNING: *Before using the product, make sure to read and understand the Material Safety Data Sheet supplied by the manufacturer or supplier.*

WARNING: *Wear safety goggles and protective gloves.*

NOTE: *Always follow the relevant supplier's recommendations.*

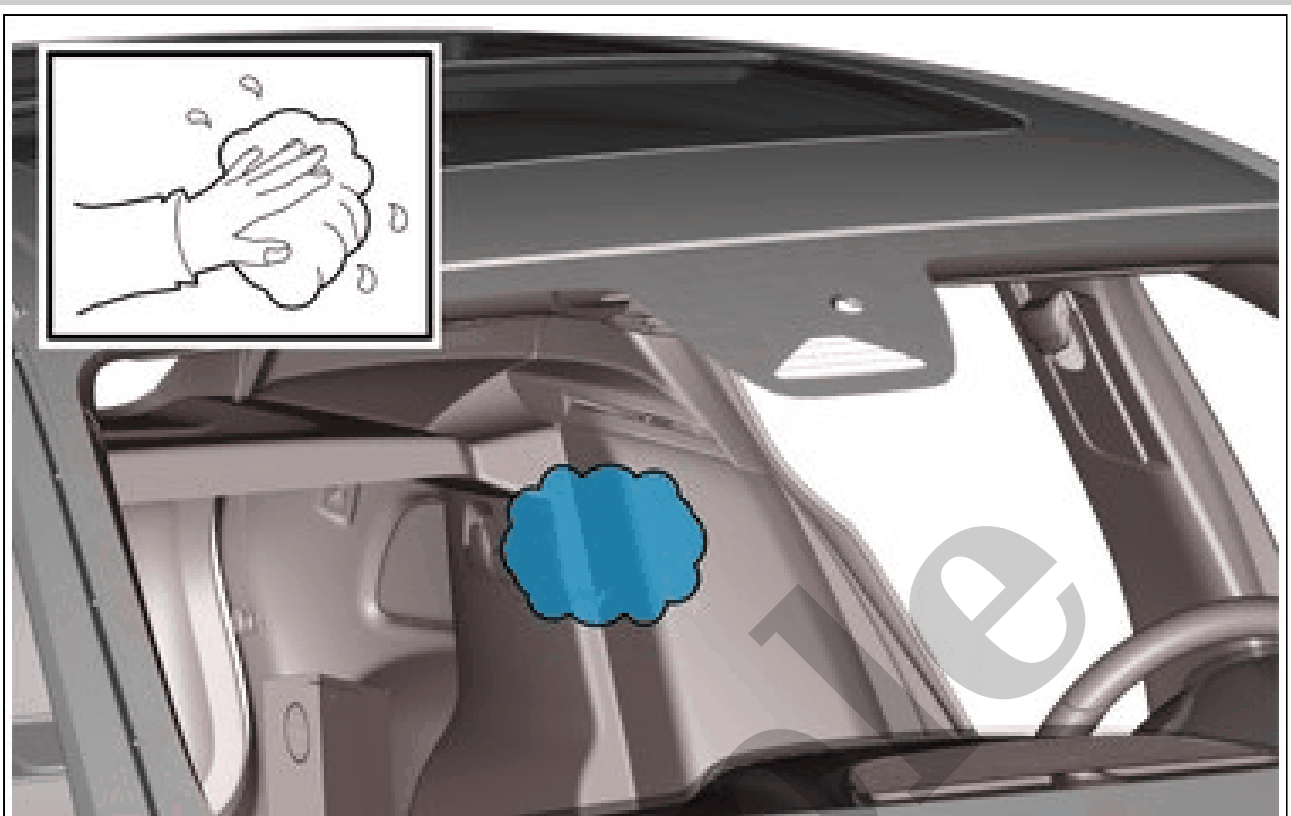

Courtesy of VOLVO CARS CORPORATION



Courtesy of VOLVO CARS CORPORATION

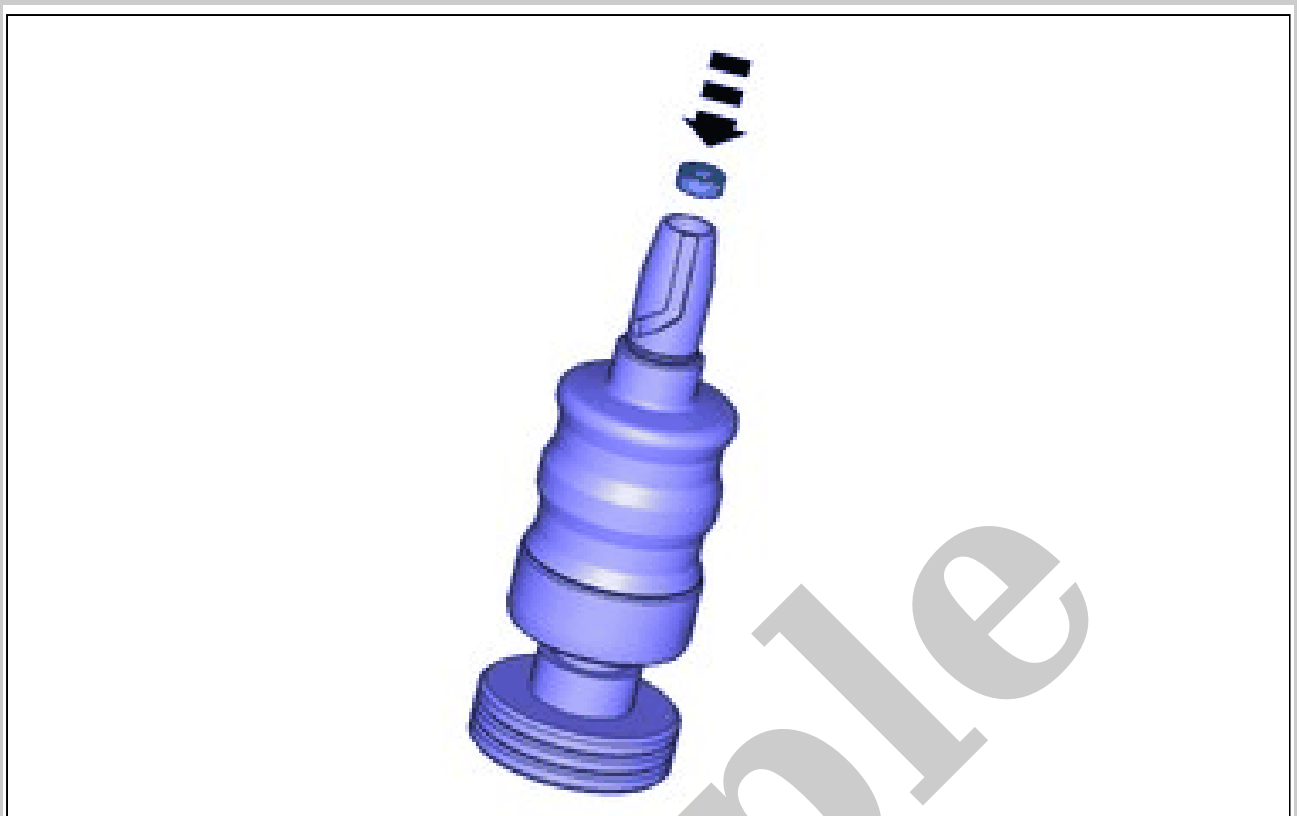

Courtesy of VOLVO CARS CORPORATION

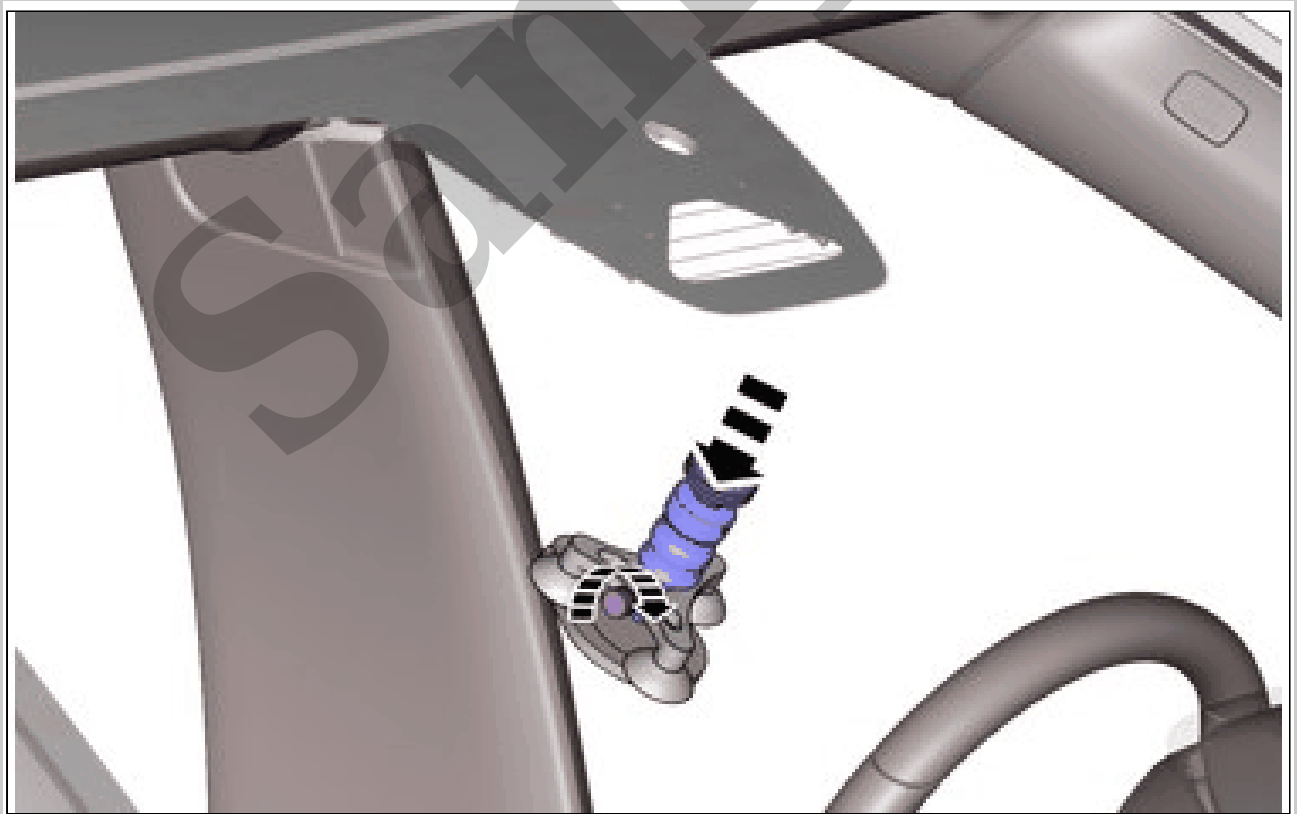

Courtesy of VOLVO CARS CORPORATION

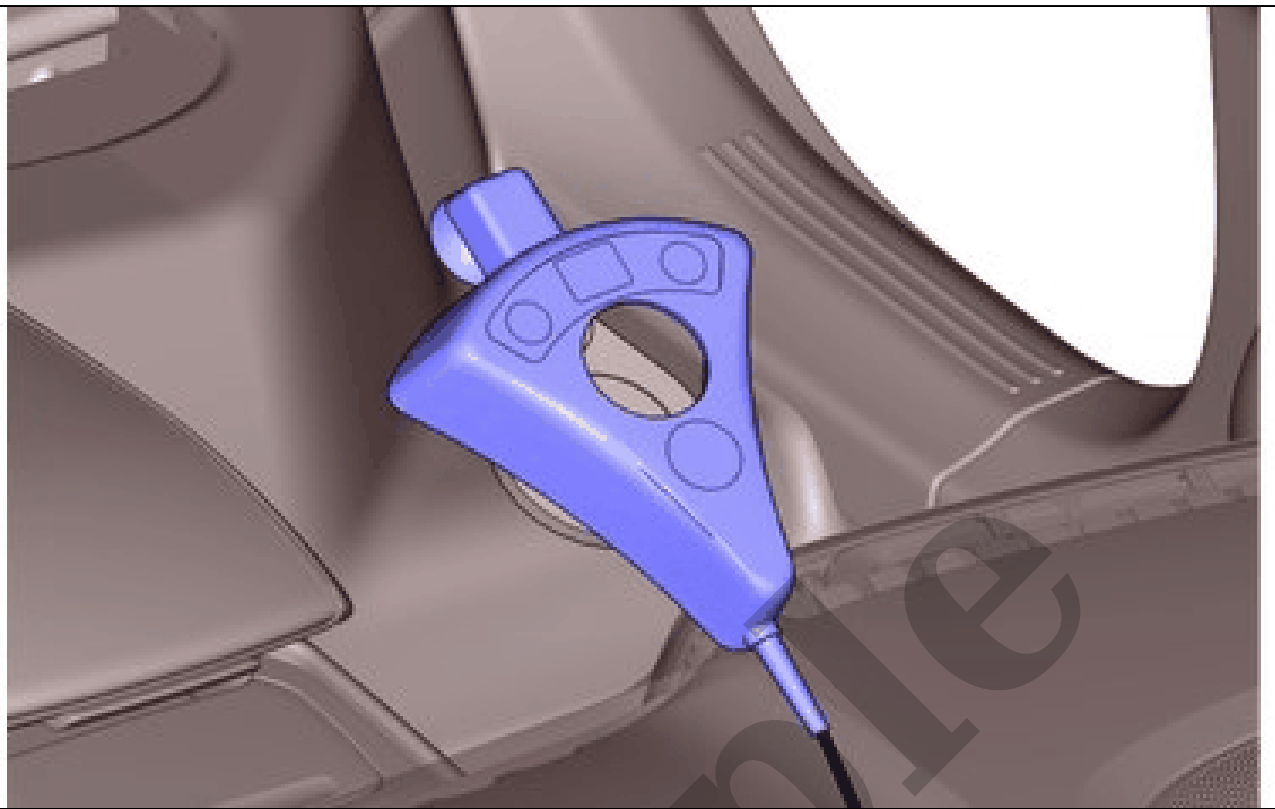

Courtesy of VOLVO CARS CORPORATION

Use UV light to cure the resin filler.