

# Your Ultimate Source for OEM Repair Manuals

FactoryManuals.net is a great resource for anyone who wants to save money on repairs by doing their own work. The manuals provide detailed instructions and diagrams that make it easy to understand how to fix a vehicle.

## 2009 VOLVO C30 OEM Service and Repair Workshop Manual

[Go to manual page](#)

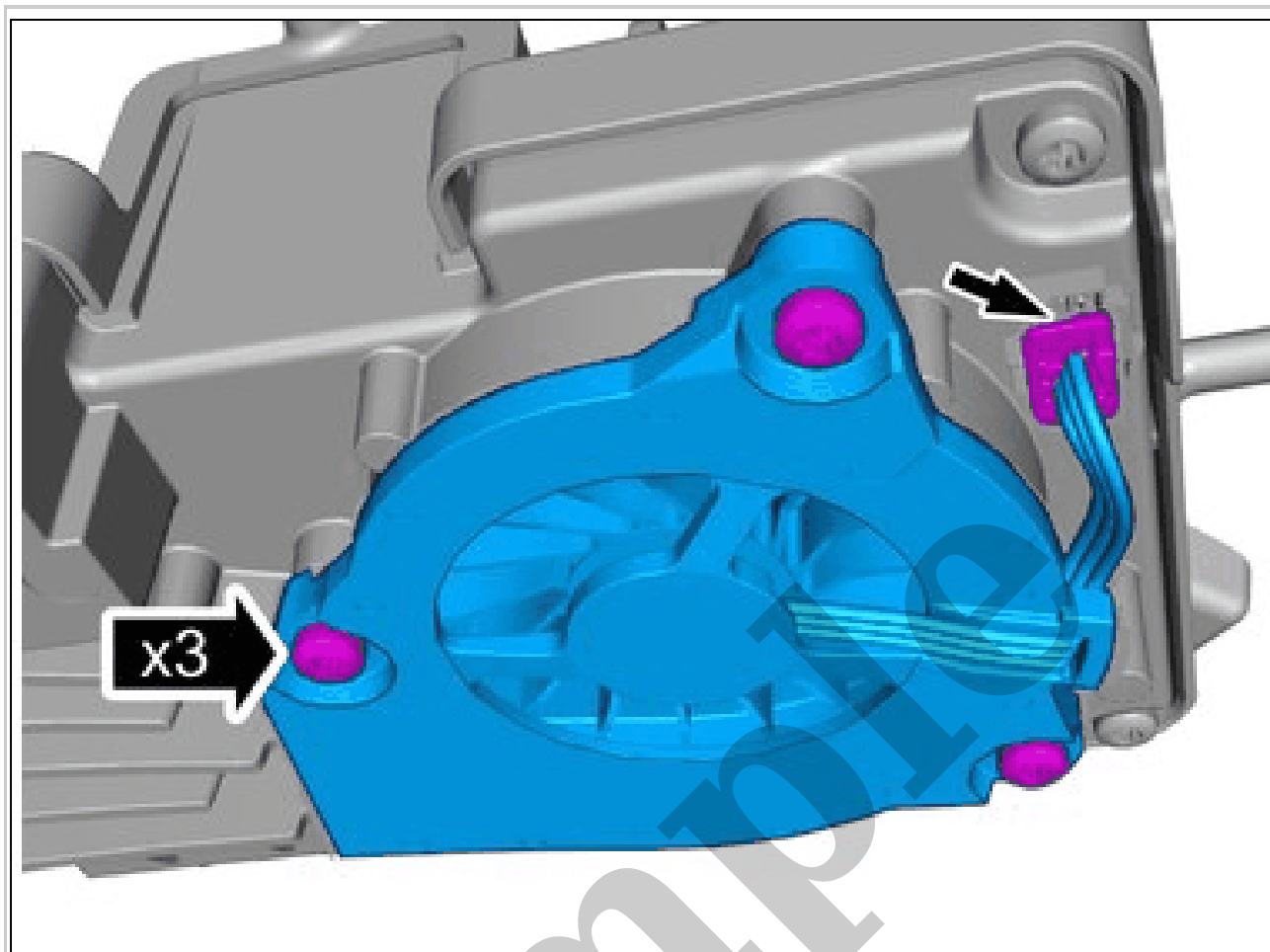

Courtesy of VOLVO CARS CORPORATION

Disconnect the connector.  
Remove the screws.  
Remove the marked part.

**COOLING FAN, FORWARD LOOKING CAMERA > COOLING FAN, FORWARD  
LOOKING CAMERA (FLC) [2022 | 2021, E400V6] > INSTALLATION**



Courtesy of VOLVO CARS CORPORATION

Remove the marked part.

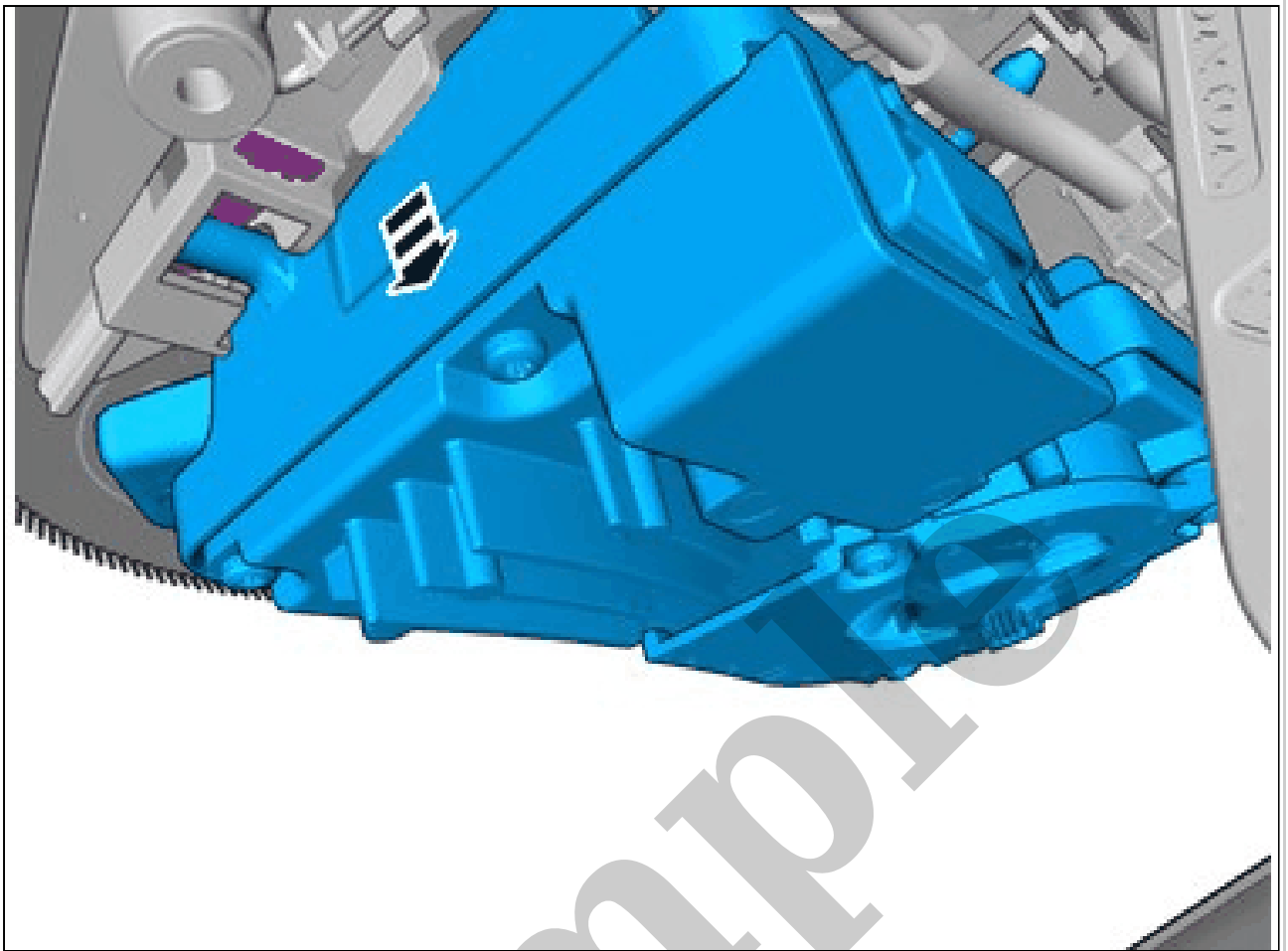

Courtesy of VOLVO CARS CORPORATION

Tilt the component somewhat.

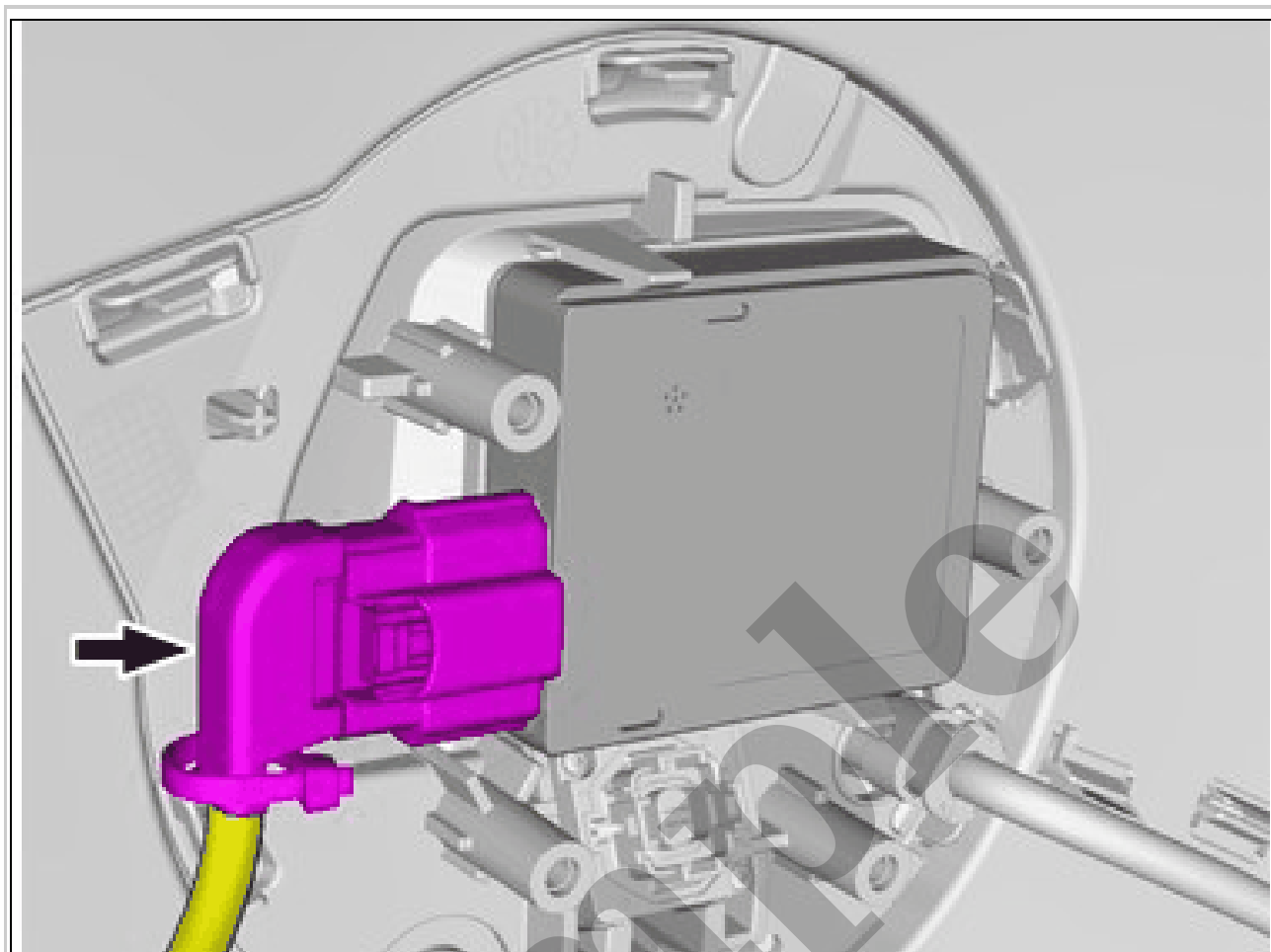

Courtesy of VOLVO CARS CORPORATION

Release the connector's catch.  
Disconnect the connector.

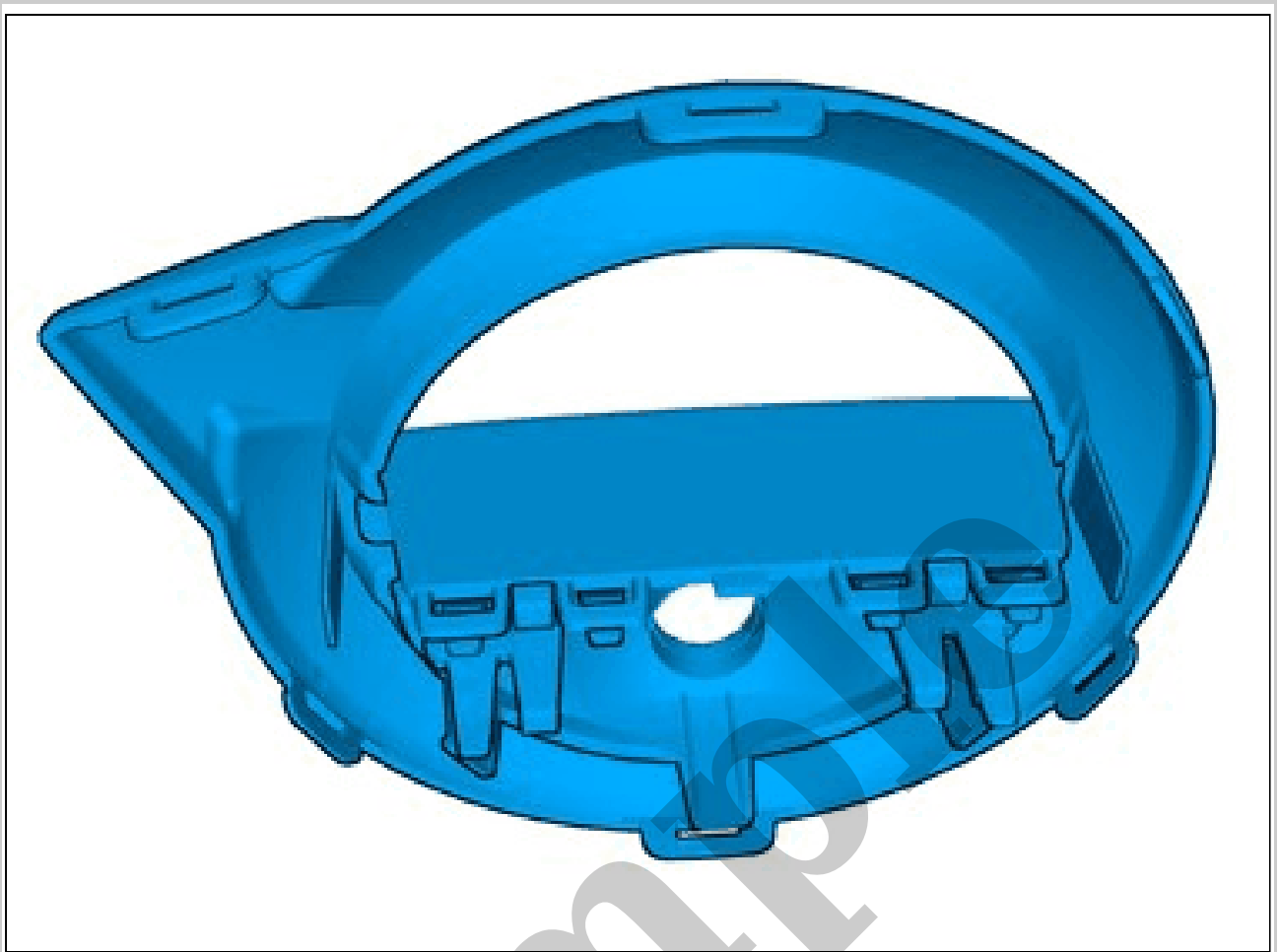

Courtesy of VOLVO CARS CORPORATION

**NOTE:** *The graphic shows the back of the component before removal.*

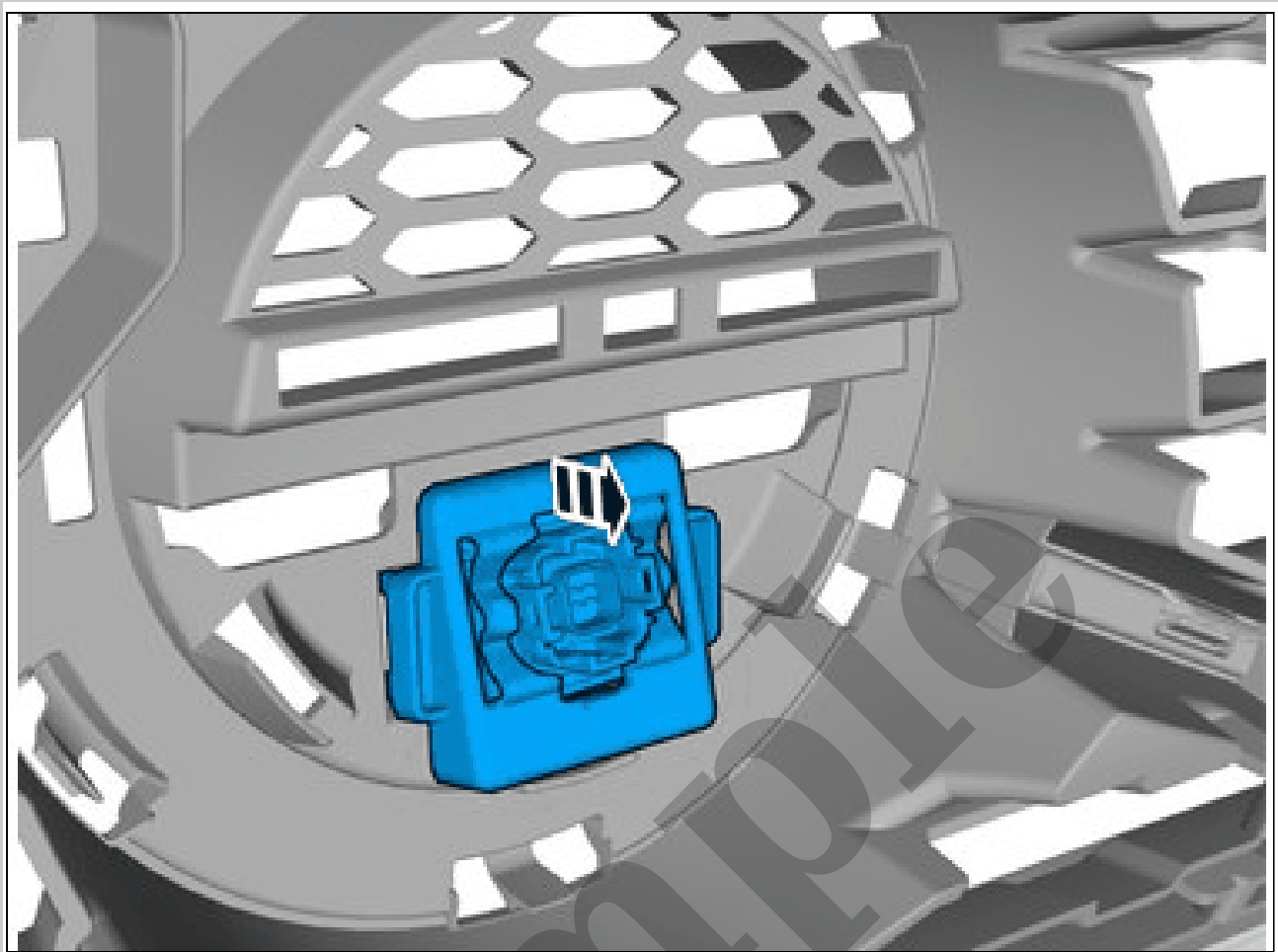

Courtesy of VOLVO CARS CORPORATION

Remove the marked part.

### **PARKING ASSISTANCE CAMERA, FRONT > PARKING ASSISTANCE CAMERA, FRONT [2018-2020 | 2021-2022, B4204T18 | 2021-2022, B4204T47] > INSTALLATION**

To install, reverse the removal procedure.

Calibrate WAM according to: Diagnostics / Components / Control modules /Wide Angle Vision Module (WAM) / Diagnostic sequences / Calibrating parking assistance cameras

### **PARKING ASSISTANCE CAMERA, FRONT > PARKING ASSISTANCE CAMERA, FRONT [2021-2022, E400V6] > REMOVAL**

Perform battery disconnecting and connecting. Refer to: BATTERY DISCONNECTING AND CONNECTING

Remove casing bumper front. Refer to: COVER BUMPER FRONT

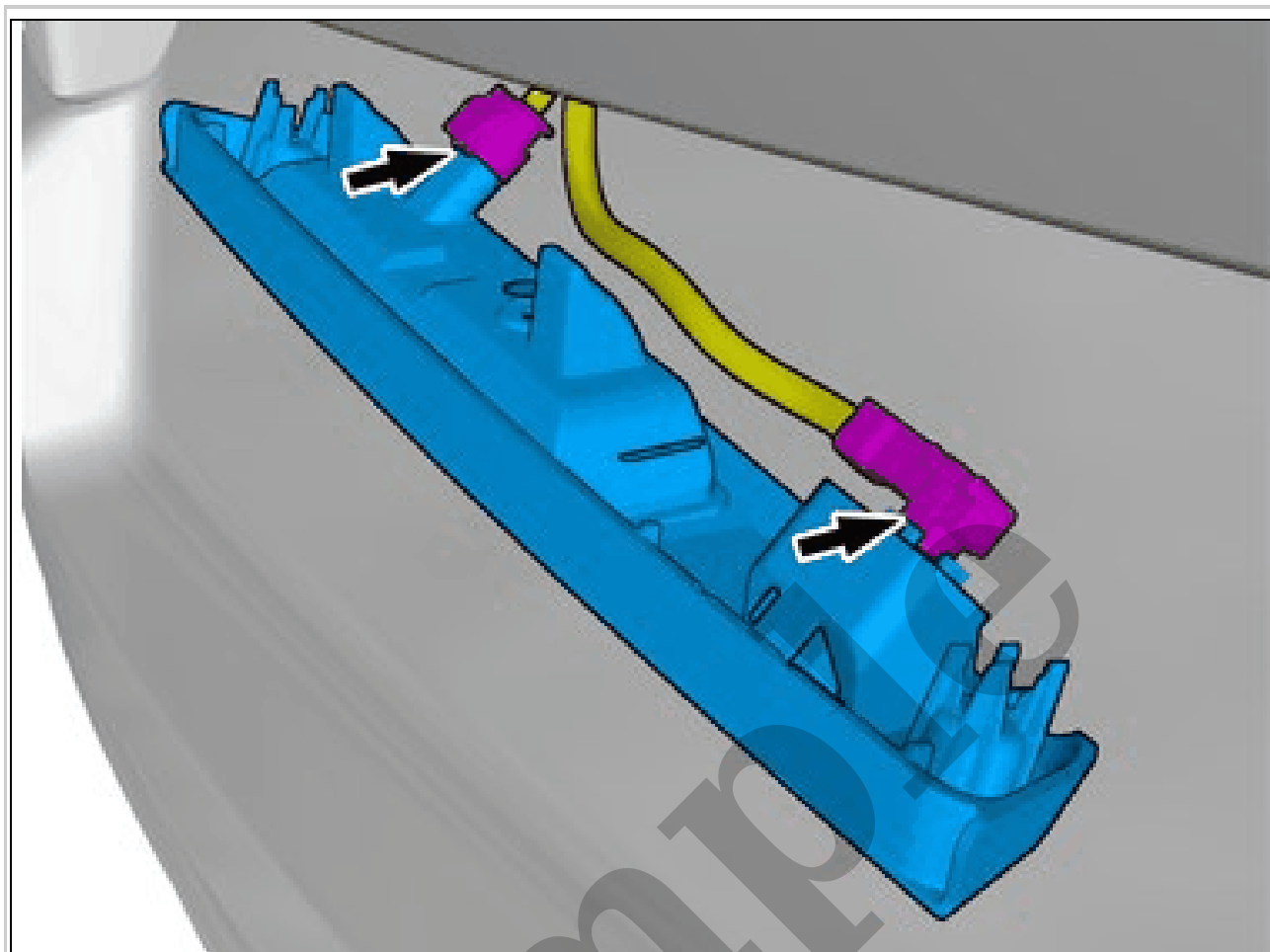

Courtesy of VOLVO CARS CORPORATION

Disconnect the connectors.  
Remove the marked part.



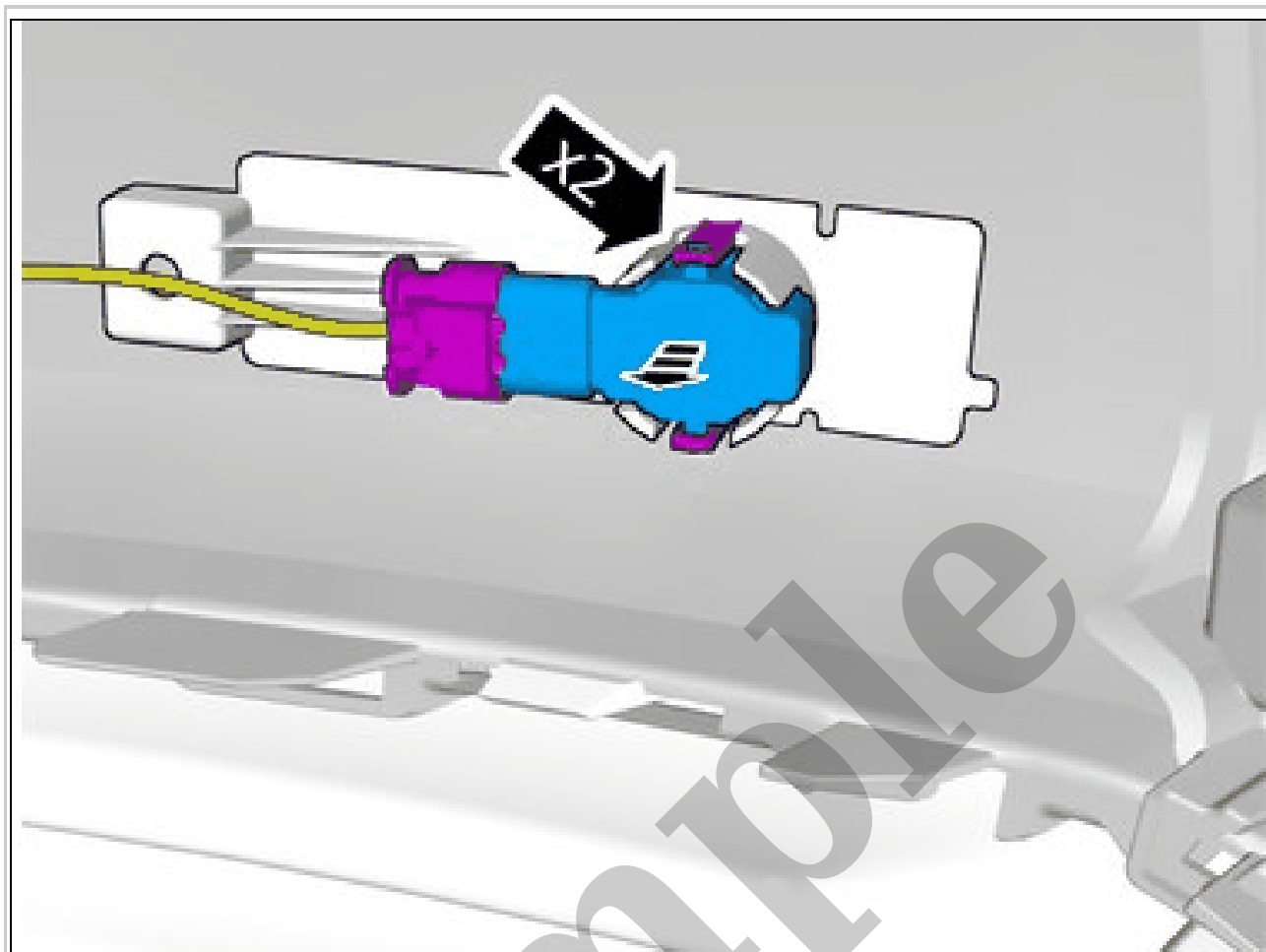

Courtesy of VOLVO CARS CORPORATION

Disconnect the connector.  
Release the catches.  
Remove the marked part.

## PARKING ASSISTANCE SENSOR, FRONT > PARKING ASSISTANCE SENSOR, FRONT [2018-2019] > INSTALLATION

**NOTE:** *The following steps are only necessary when installing a new component.*

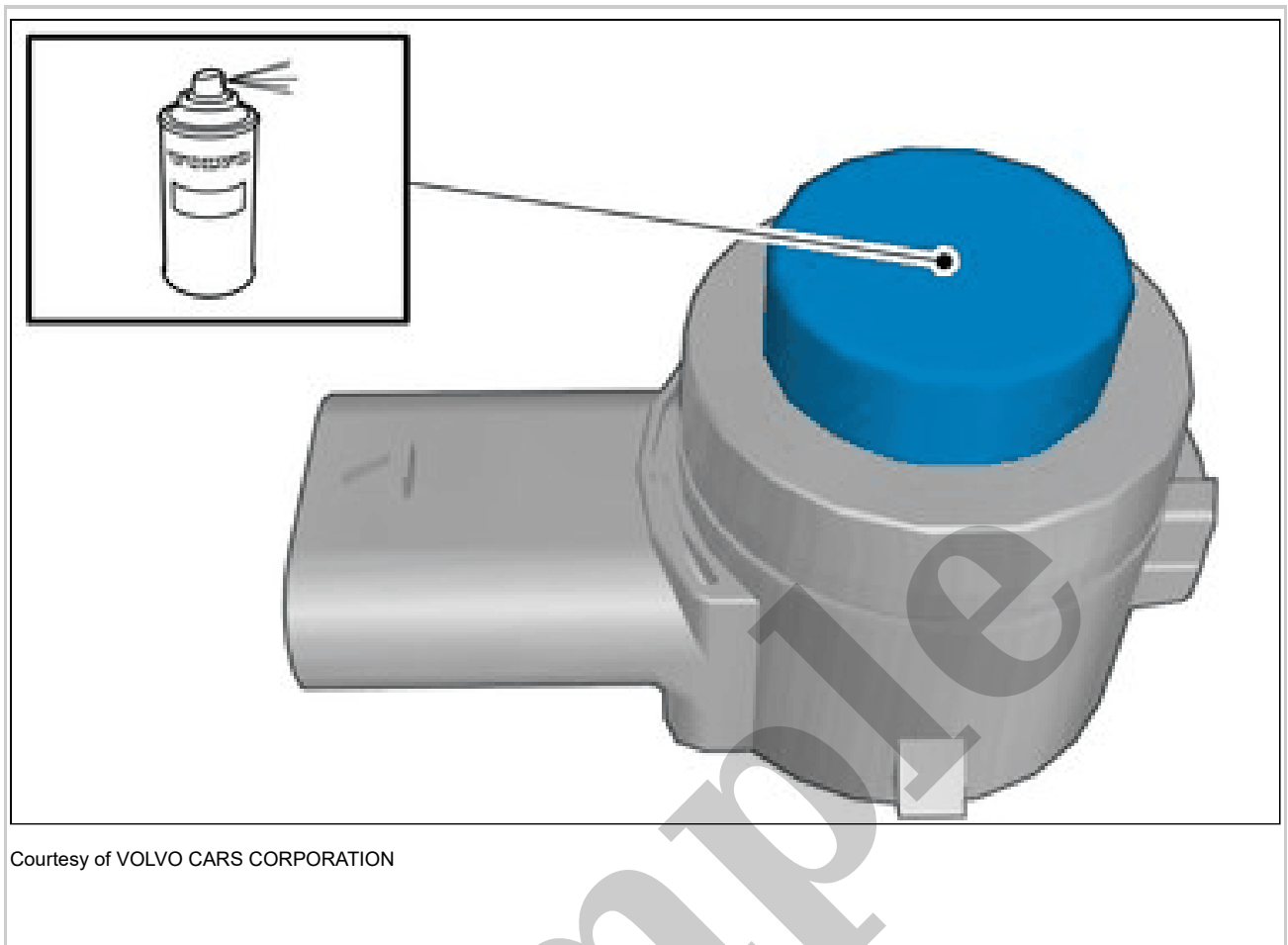

Courtesy of VOLVO CARS CORPORATION

**CAUTION:** *Protect connector surfaces against paint spray.*

**NOTE:** *Paint the sensors the same color code as the vehicle.*

**Use:** Volvo Original Touch-up paint,  
Use base coat only.

**Use:** Varnish 2-component, 31335447  
Also see the instructions on the container.