

Your Ultimate Source for OEM Repair Manuals

FactoryManuals.net is a great resource for anyone who wants to save money on repairs by doing their own work. The manuals provide detailed instructions and diagrams that make it easy to understand how to fix a vehicle.

2009 NISSAN Primera Sedan OEM Service and Repair Workshop Manual

[Go to manual page](#)

d Stick the heat shield sheet in the following procedure.

- Stick the heat shield sheet ① to the battery pack upper case rear as shown in the figure.

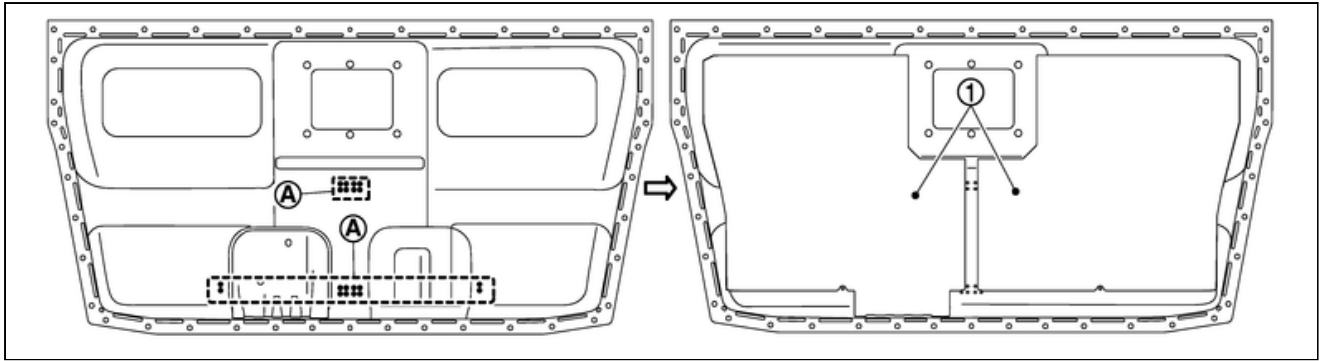

RPR-001999648-03-000402173

Ⓐ	Position mark (Projection)
---	----------------------------



NOTE:

- Stick the heat shield sheet that hides the inner position mark where two position marks are lined up.
- Part ② does not have any problem even if it gets wrinkled when sticking the heat shield sheet.

e After sticking the heat shield sheet, press the whole by hands.

2 Install seal to battery pack upper floor assembly.

WARNING:



To prevent electric shock, wear insulated protective gear.



CAUTION:

The flat side ① of seal faces battery pack lower case.

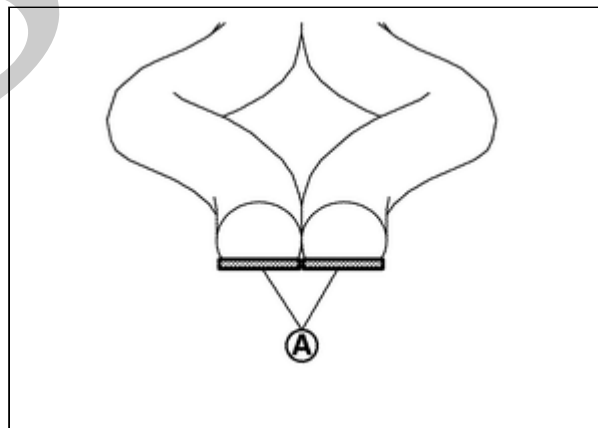

RPR-001999648-19-000369880

3 Install guide pin [SST: KV99119600 (J-53348)] (A) to the center of battery pack upper floor assembly.

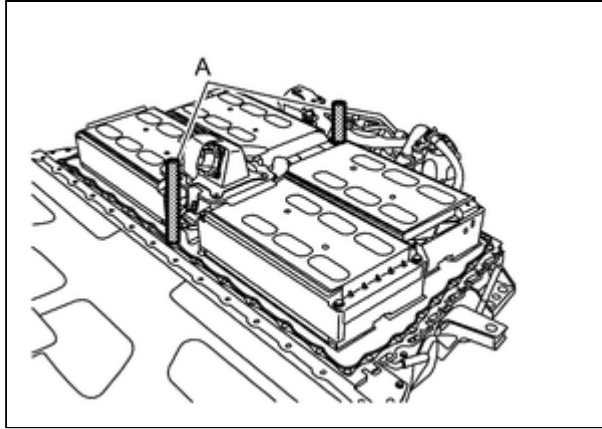

RPR-001999648-10-000402149

WARNING:



To prevent electric shock, wear insulated protective gear.



4 Install insulator cover

CAUTION:

Hold the base sheet (clear) part of the insulator cover, and do not hold the form (white) and EPT sealer (black).

5 Install the seal of service plug bracket.

6 Hold both sides of the battery pack upper case to install it.

7 Install each bolt and for each retainer (FR, RR, LH and RH).

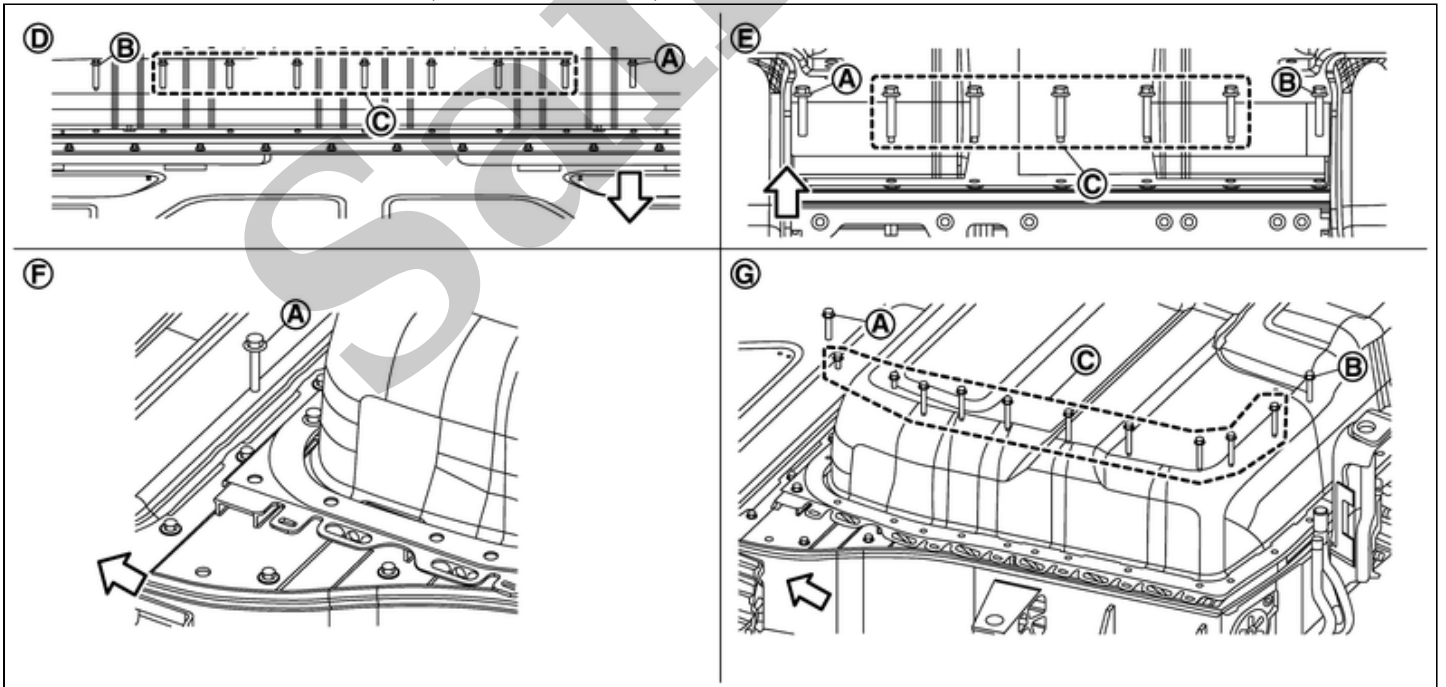

RPR-001999648-18-000402150



NOTE:

- Tighten each retainer bolt in the order of (A) → (B) → (C).

(A), (B)	: 11.1 N.m (1.1kg-m, 8 ft-lb)
(C)	: 8.0 N.m (0.82 kg-m, 71 in-lb)

Ⓓ	: Retainer (FR)
Ⓔ	: Retainer (RR)
Ⓕ	: Both side front
Ⓖ	: Retainer (LH), Retainer (RH)
←	: Battery front

WARNING:

 To prevent electric shock, wear insulated protective gear.



8 Install left and right resin retainer.

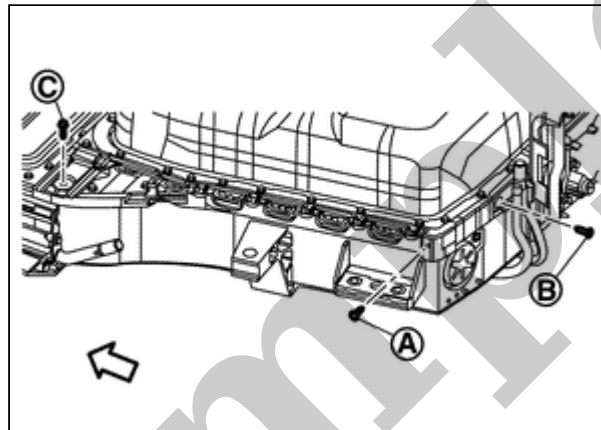

RPR-001999648-17-000402151

←	: Battery front
	: 8.0 N.m (0.82 kg-m, 71 in-lb)

 **NOTE:**

- The figure shows the left side.
- Tighten bolts in the order of Ⓐ → Ⓑ → Ⓒ.

WARNING:

 To prevent electric shock, wear insulated protective gear.



9 Install service plug retainer.

10 Install Li-ion battery cooler tube to battery pack upper floor assembly. Refer to [Disassembly & Assembly](#).

11 Install battery heater bracket to battery pack lower case.

BATTERY PACK UPPER CASE FRONT

REMOVAL

1 Remove left and right retainers ①.

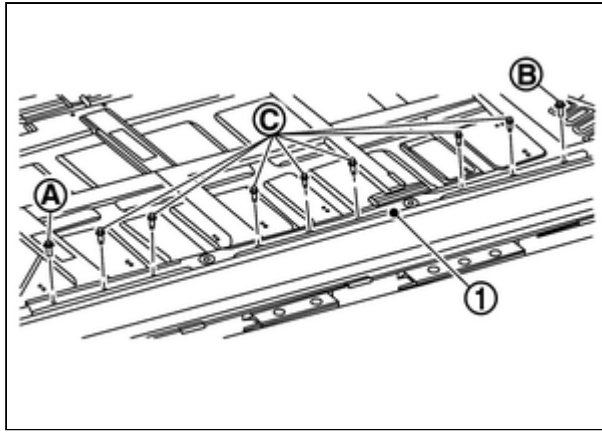

RPR-001999648-22-000360457



NOTE:

- The figure shows the left side.
- Remove bolts for each retainer in the order of C → B → A.

WARNING:



To prevent electric shock, wear insulated protective gear.



2 Remove left and right resin retainers in the order of 3 → 2 → 1

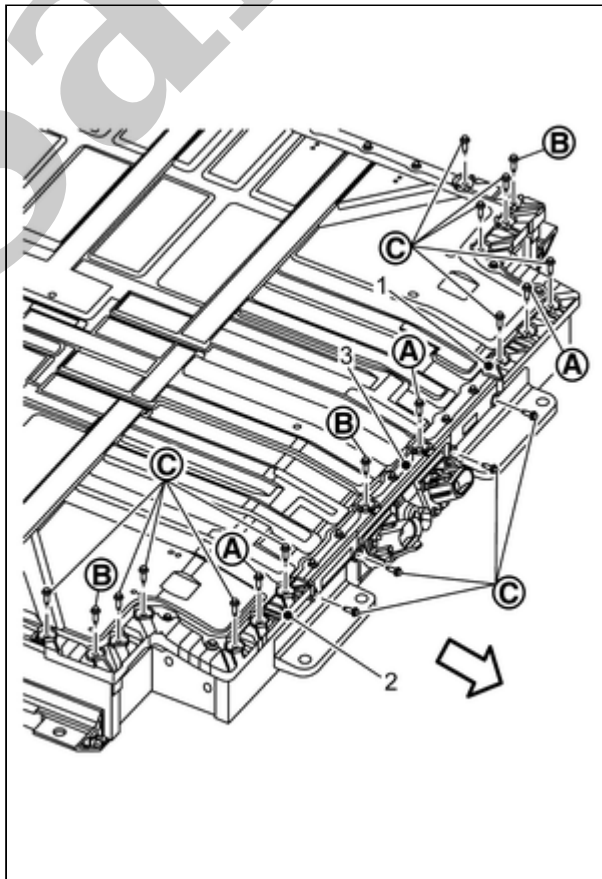

RPR-001999648-26-000360460



: Battery front



NOTE:

Remove bolts for each resin retainer in the order of C → B → A.

WARNING:



To prevent electric shock, wear insulated protective gear.



3 Remove retainer ①.

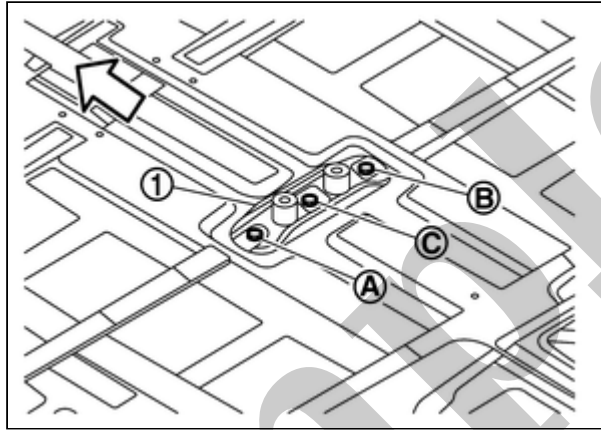

RPR-001999648-37-000360461



: Battery front



NOTE:

Remove bolts in the order of C → B → A.

WARNING:



To prevent electric shock, wear insulated protective gear.



4 Remove bolt ①.

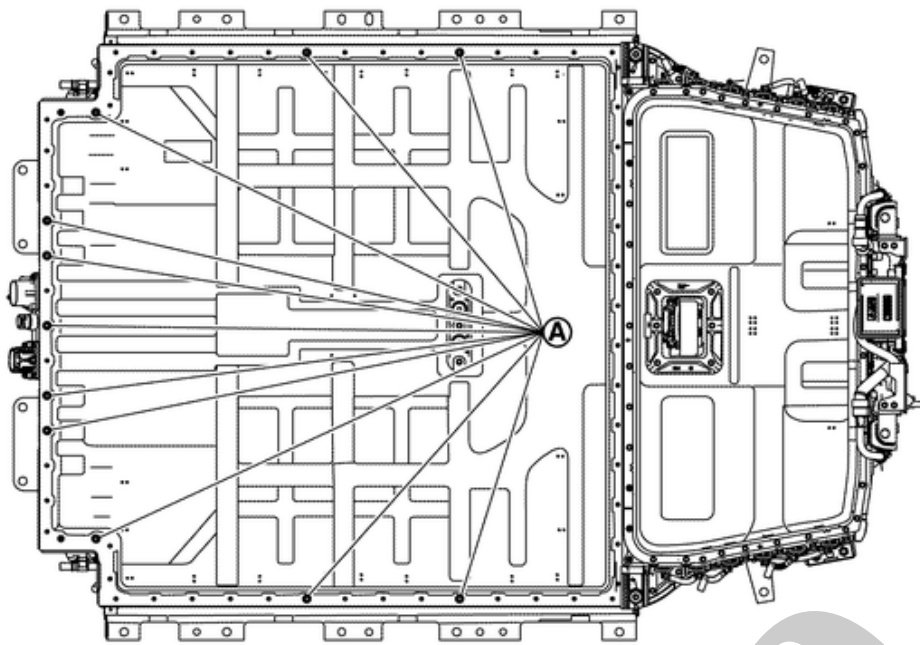

RPR-001999648-09-000402175

WARNING:

 To prevent electric shock, wear insulated protective gear.



5 Remove bolt of backward on the battery pack upper case front.

6 Hold both sides of the battery pack upper case front to remove it.

WARNING:

 To prevent electric shock, wear insulated protective gear.



7 Remove seal from battery pack lower case.

WARNING:

 To prevent electric shock, wear insulated protective gear.



INSTALLATION

1 Check that heat shield sheet is still stuck back of battery upper case front.

- When the sheet is peeled or battery pack upper case front is replaced, stick new heat shield sheet according to the following procedure.

a Place the battery pack upper case front on a pre-cured area so that the outside of the battery pack upper case front is not damaged

b Wipe the surface of the battery pack upper case front where the heat shield sheet are stuck with a dry cloth to remove oil and dust.

c If the temperature of the work space is 15 °C (59 °F) or less, heat the surface of the battery pack upper case front where heat shield sheet are stuck to 15 - 50 °C (59 - 112 °F) with a heat gun or equivalent.

CAUTION:

Work on carton box to prevent the warmed heat from escaping.

- For the battery pack upper case front, warm the surface where the heat shield sheet are stuck for at least 5 minutes so that the entire surface is at least 15 °C (59 °F).
- Remove the release paper from the heat shield sheet, and then heat the side stuck to battery pack upper case for at least 1 minute so that its temperature is 15 °C (59 °F) or higher.

d Stick the heat shield sheet ①, ② and ③ to the battery pack upper case front as shown in the figure.

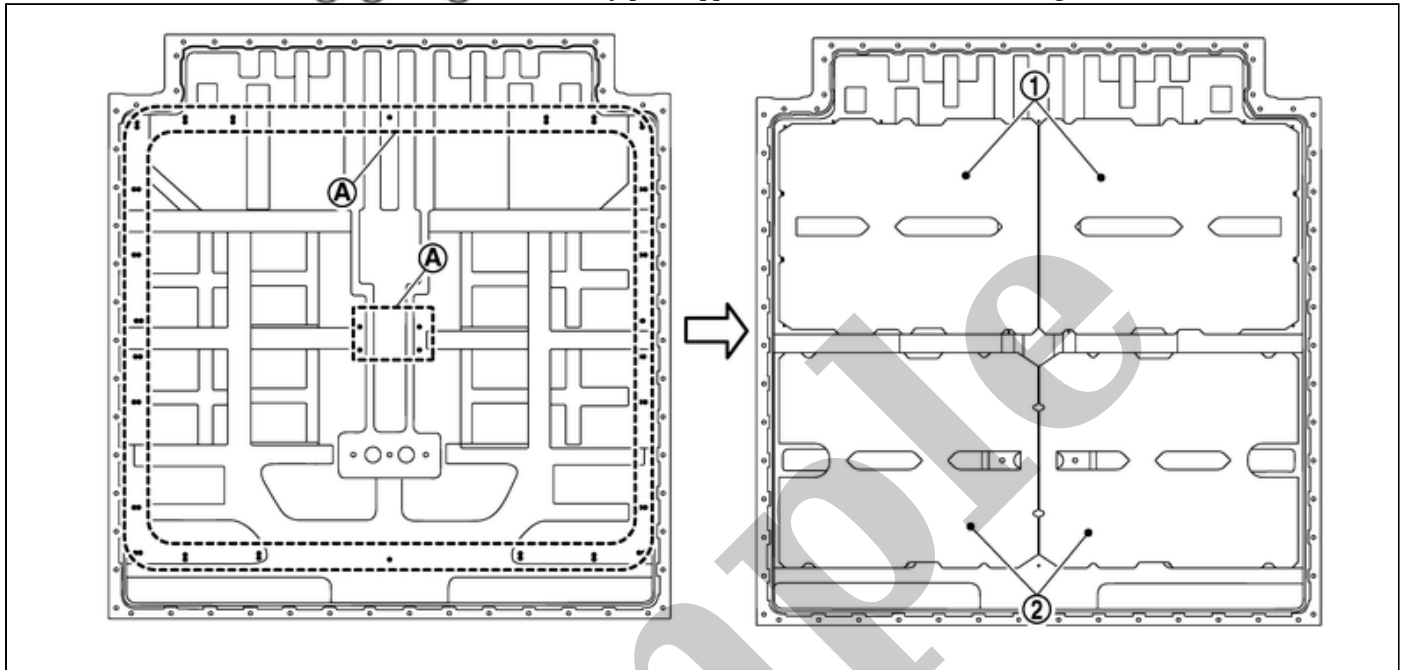

RPR-001999648-04-000402174

Ⓐ	Position mark (Projection)
---	----------------------------



NOTE:

Stick the heat shield sheet that hides the inner position mark where two position marks are lined up.

e After sticking the heat shield sheet, press the whole by hands.

2 Install seal to battery pack lower case.

WARNING:



To prevent electric shock, wear insulated protective gear.



CAUTION:

The flat side Ⓐ of seal faces battery pack lower case.

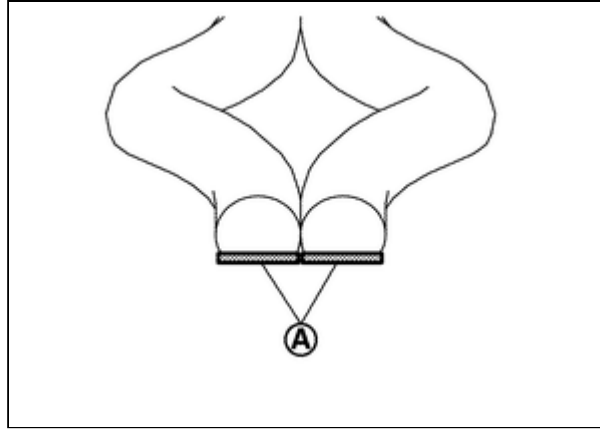

3 Hold both sides of battery pack upper case front and install it.



WARNING:

 To prevent electric shock, wear insulated protective gear.

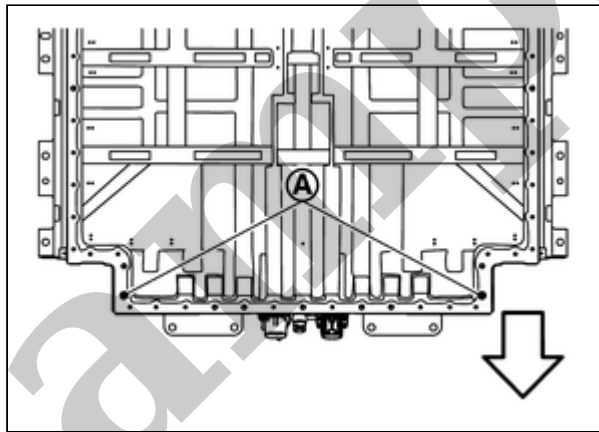

4 Tighten bolts .



	: Battery front
	: 11.1 N.m (1.1 kg-m, 8 ft-lb)

WARNING:

 To prevent electric shock, wear insulated protective gear.



5 Install retainer .

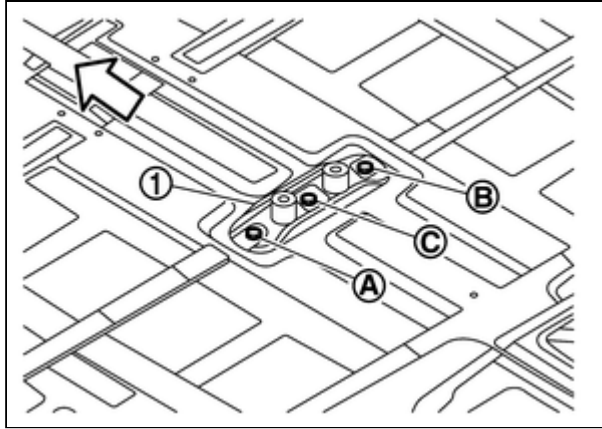

RPR-001999648-13-000360461

	: Battery front
	: 8.0 N.m (0.82 kg-m, 71 in-lb)



NOTE:

Tighten bolts in the order of (A) → (B) → (C).

WARNING:





To prevent electric shock, wear insulated protective gear.

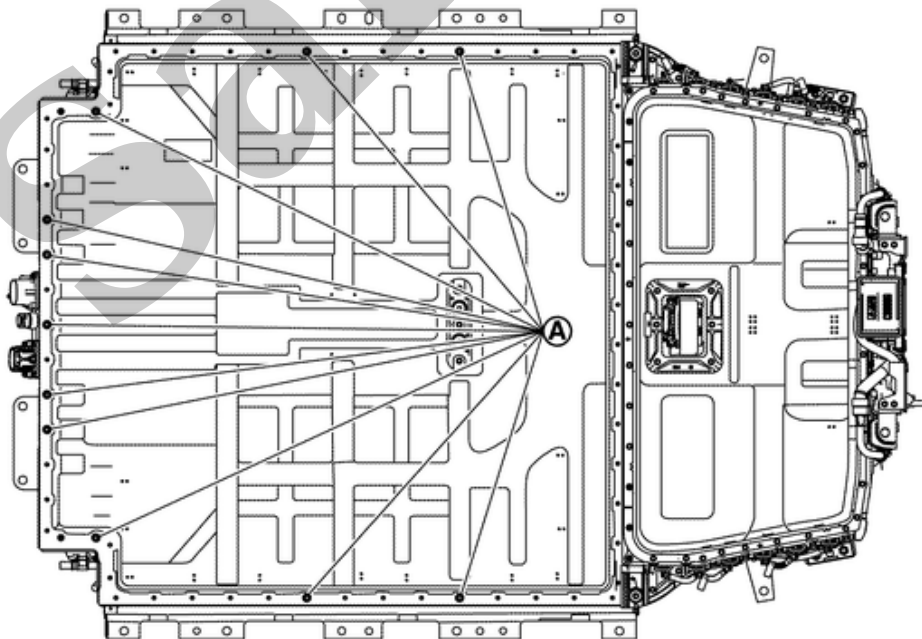

6 Tighten bolt (A).



RPR-001999648-08-000402175

	: Battery front
	: 8.0 N.m (0.82 kg-m)

WARNING:



To prevent electric shock, wear insulated protective gear.