

Your Ultimate Source for OEM Repair Manuals

FactoryManuals.net is a great resource for anyone who wants to save money on repairs by doing their own work. The manuals provide detailed instructions and diagrams that make it easy to understand how to fix a vehicle.

2009 NISSAN Patrol SWB OEM Service and Repair Workshop Manual

[Go to manual page](#)

SEC. 291•740

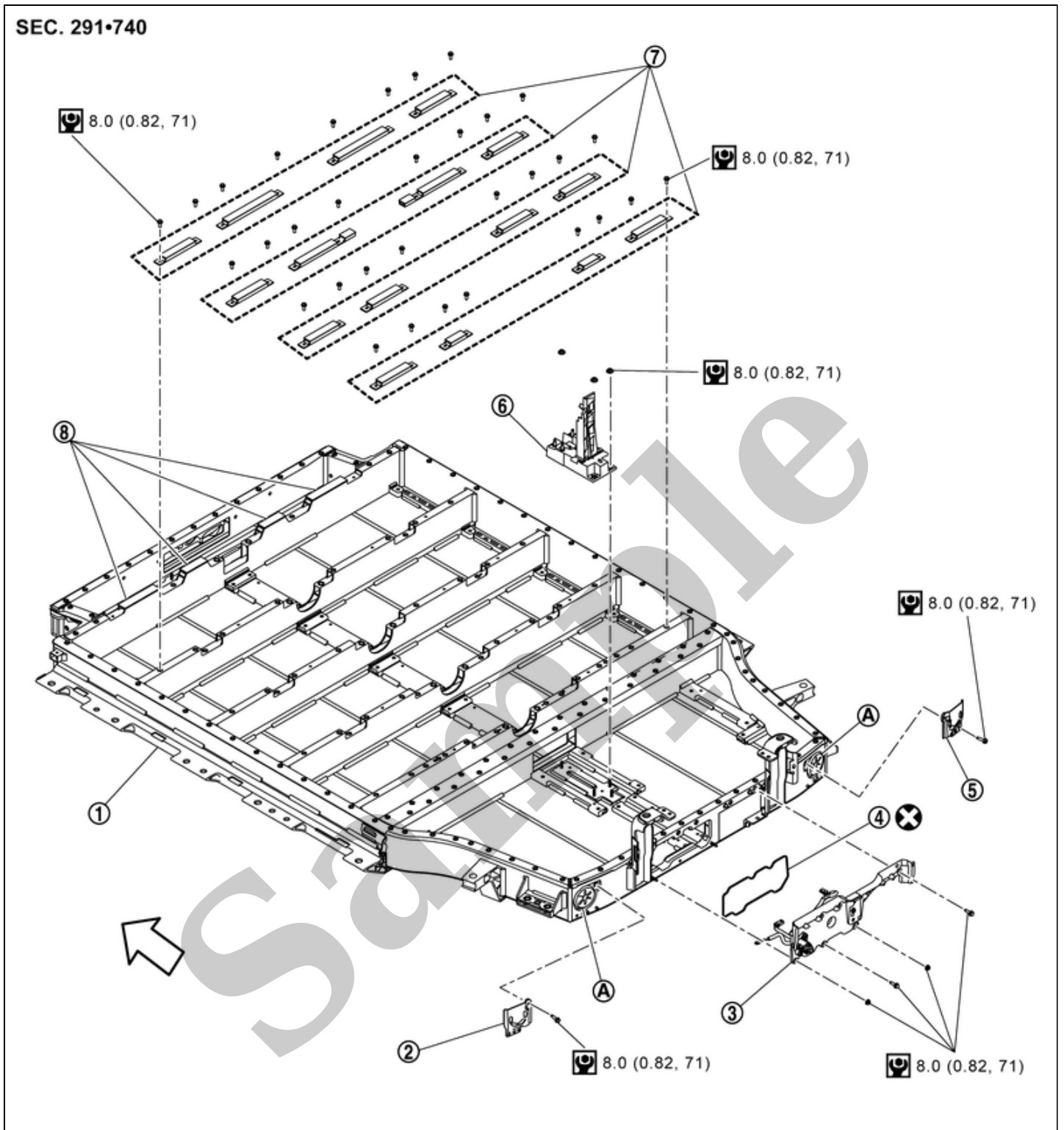

RDE-001999663-01-000402137

①	Battery pack lower case	②	Battery ventilation valve cover LH	③	Rear box
④	Seal	⑤	Battery ventilation valve cover RH	⑥	Terminal block
⑦	Bracket with ept sealer	⑧	Ept sealer		
A	Battery ventilation valve				
←	: Vehicle front				
⊗	: Always replace after every disassembly.				
🔩	: N·m (kg-m, in-lb)				

DANGER:

Because hybrid vehicles and electric vehicles contain a high voltage battery, there is a risk of electric shock, electric leakage, or similar accidents if the vehicle is handled incorrectly. Be sure to follow the correct work procedures when performing inspection and maintenance.

WARNING:

- Be sure to remove the service plug in order to shut off the high voltage circuits before performing inspection or maintenance of high voltage system harnesses and parts.
- Be sure to put the removed service plug in pocket and carry it or store it in a tool box or other container so that another person does not accidentally connect it while work is in progress.
- Be sure to put on insulating protective gear before beginning work on the high voltage system.
- Clearly identify the persons responsible for high voltage work and ensure that other persons do not touch the vehicle. When not working, cover high voltage components with an anti-static cover sheet or similar item to prevent contact with other persons.
- Refer to [PRECAUTIONS FOR HIGH VOLTAGE : Precautions](#).
- If the battery pack is to be disassembled, be sure to remove the Li-ion battery controller for preventing electric shock, fire, and damage to parts.

CAUTION:

There is the possibility of a malfunction occurring if the vehicle is changed to READY status while the service plug is removed. Therefore do not change the vehicle to READY status unless instructed to do so in the Service Manual.

ENVIRONMENT FOR LI-ION BATTERY DISASSEMBLY WORK

1 Must be an indoor environment.

- The environment must utilize a shutter or other means to shut out the outside environment and prevent rain, snow, dust, or other substances from entering.
- The environment must not cause the intrusion of sweat during work, or cause condensation to occur due to high temperature or humidity.

2 Metal powder, grease, and other foreign substances must not enter.

- The indoor environment must also prevent metal powder, grease, and other foreign substances from entering due to maintenance performed on other vehicles and other sources during disassembly work.
- If there is a risk of the above substances entering, take appropriate countermeasures, such as use of a vinyl curtain or an equivalent to shut out the outside environment.

3 The floor must be dry.

- The floor must not be wet as a result of factors such as vehicle entry during rain or snow.

4 Work space

- The work space must be approximately the size of one entire vehicle.
- Take appropriate countermeasures so that persons other than the operator do not enter the work space, such as by placing signs indicating that disassembly work is in progress.

5 Standard fire fighting equipment

- Always place a standard fire fighting equipment in the disassembly work area.
- Depending on type of fire (vehicle or battery) use standard fire fighting equipment (water or extinguisher).

REAR BOX

Disassembly

1 Open bus bar terminal block and remove nut (A).

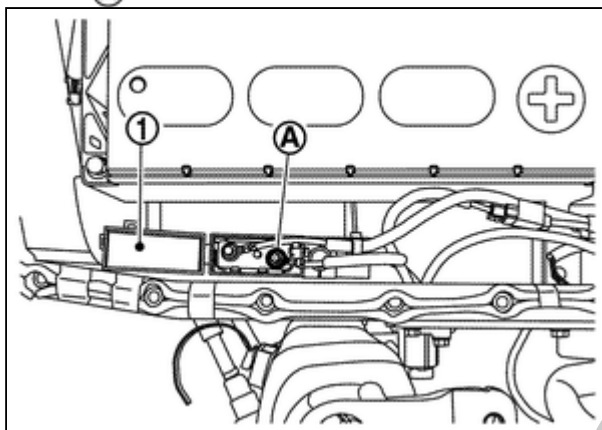

RPR-001999654-86-000360471

WARNING:



To prevent electric shock, wear insulated protective gear and use insulated tools.



2 Remove connectors (A), (B) and (C).

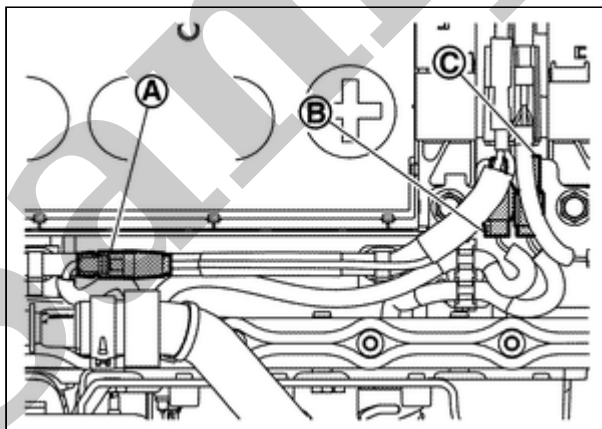

RPR-001999654-06-000402182

WARNING:



To prevent electric shock, wear insulated protective gear.



CAUTION:

Because there is the danger of electric shock, immediately insulate disconnected high voltage connectors with insulating tape.

3 Remove bolts (A) and nuts (B) and the remove rear box (1).

CAUTION:

Never loose high power bolts (C) and (D).

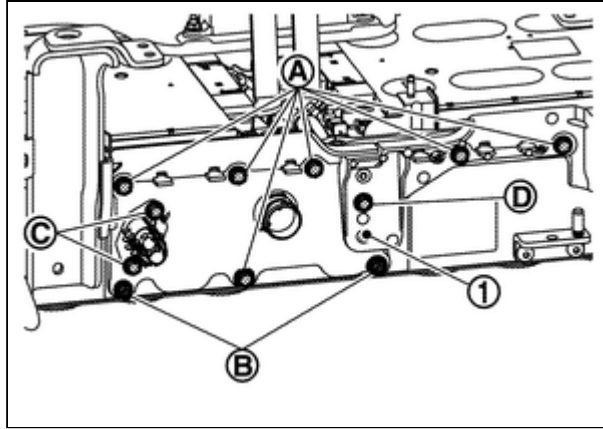

RPR-001999654-08-000360473

WARNING:



To prevent electric shock, wear insulated protective gear and use insulated tools.



4 If necessary, remove clip ① and the remove vehicle communication harness (Battery PTC) ②.

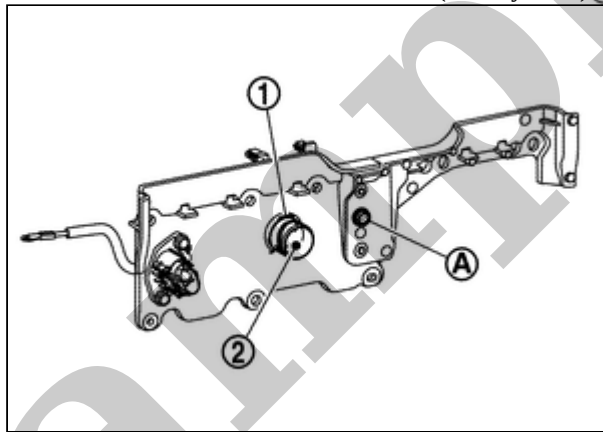

RPR-001999654-09-000360474

CAUTION:

Never loose bolt ①.

5 Remove seal from rear box.

ASSEMBLY

Note the following items, and assemble in the reverse order of disassembly.

DANGER:

-  There is the danger of electric shock caused by contact with the terminals. Be sure to wear insulated protective gear and use insulated tools.



-  Because there is a danger of electric shock and fire, never allow bus bar to contact a wrong terminal.
 - If bus bar contacts a wrong terminal, the circuit becomes energized and a short may occur.
 - Always keep the bus bar cover closed until immediately before the installation of bus bar.

BATTERY VENTILATION VALVE COVER

Disassembly

1 Remove right or left battery ventilation valve cover ①.

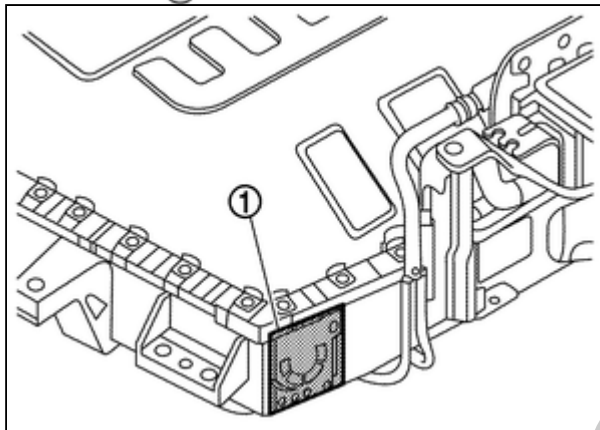

RPR-001999654-29-000360475

WARNING:



To prevent electric shock, wear insulated protective gear and use insulated tools.



Assembly

1 Install the above right or left ventilation valve cover by aligning with projection of battery pack lower case.

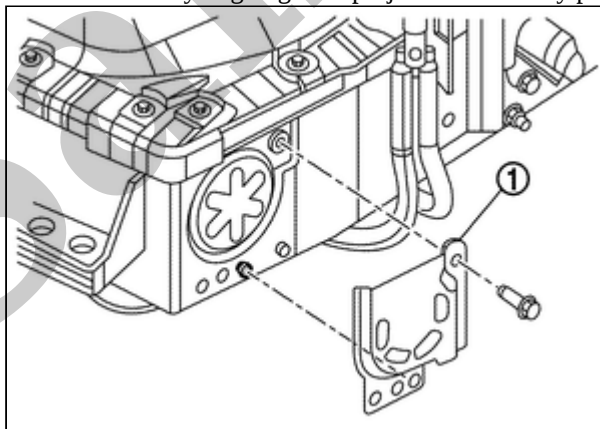

RPR-001999654-31-000360477

WARNING:



To prevent electric shock, wear insulated protective gear and use insulated tools.



EPT SEALER REPLACEMENT

1 Check the figure because the procedure differs depending on the location.

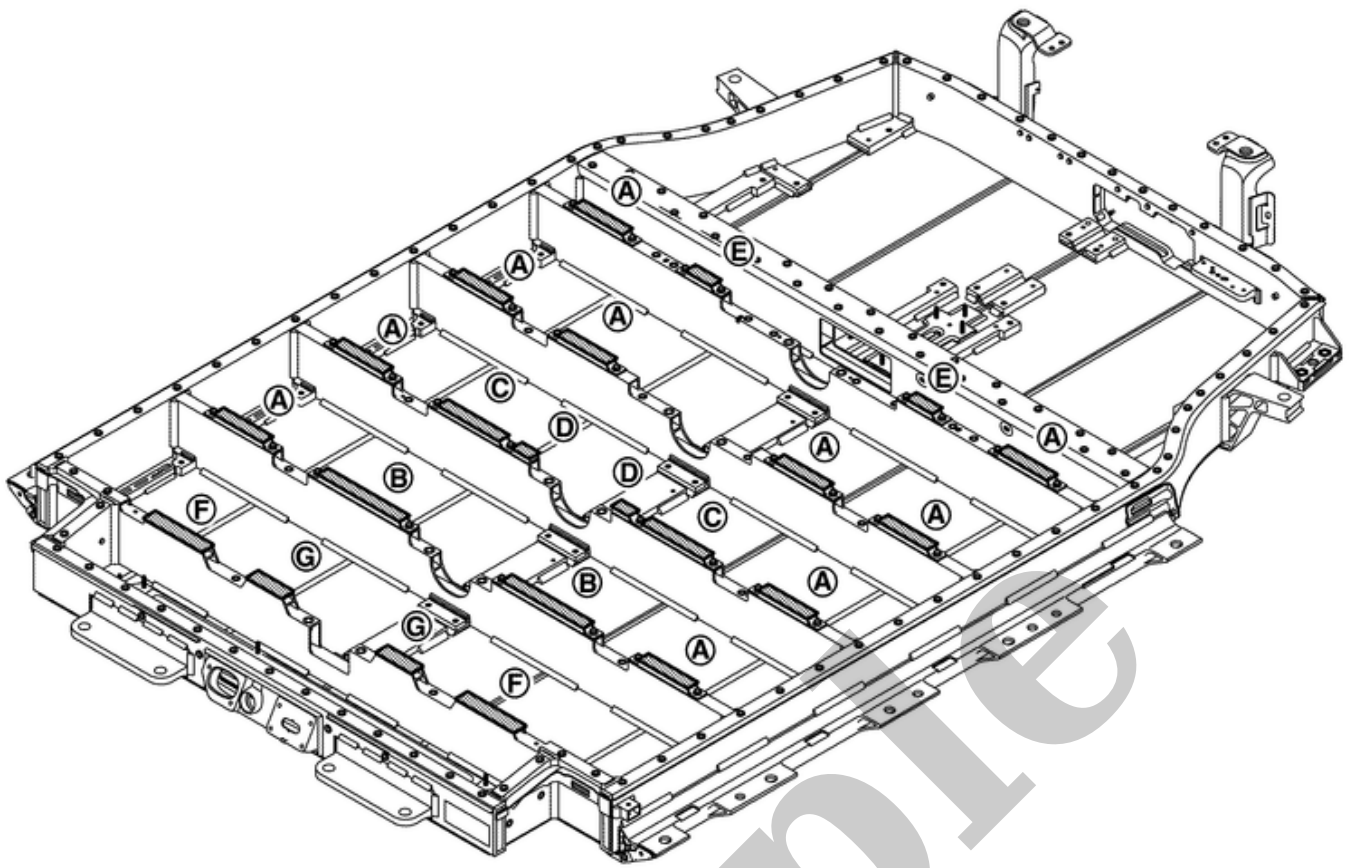

RPR-001999654-02-000402177

(A) to (E)	: Stick to bracket
(F) and (G)	: Stick to cross member of battery lower case.

2 Perform parts from (A) to (E) according to the following procedure.

a Remove the bracket that requires replacement of EPT sealer.

WARNING:



To prevent electric shock, wear insulated protective gear and use insulated tools.



b Peel EPT sealer from the bracket.

c Wipe off any dirt or oil on the surface where EPT sealer is stuck.

d Cut EPT sealer (Nissan service parts) to the required length.

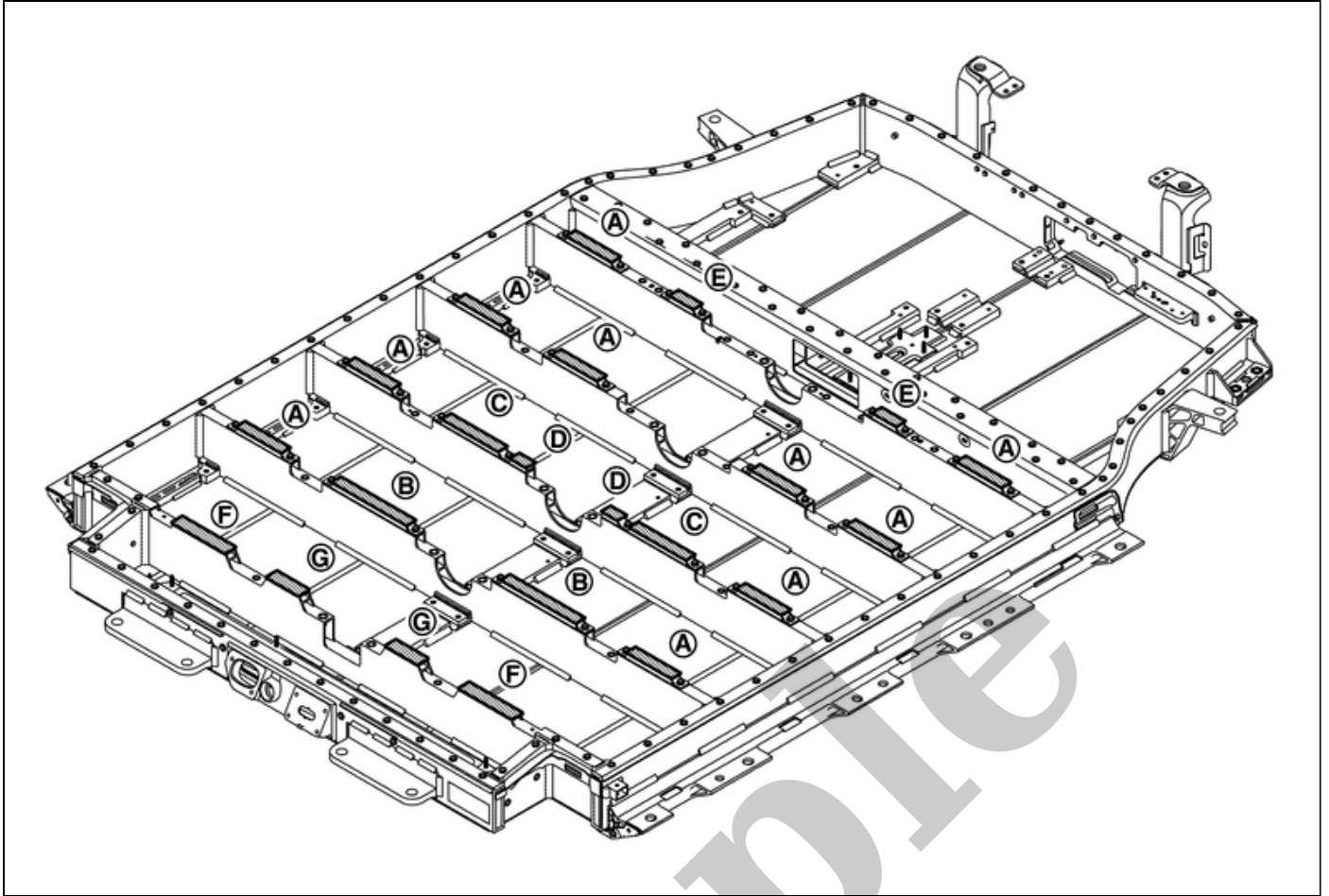

RPR-001999654-04-000402177

(A)	: 111 mm (4.37 in) × 23 mm (0.91 in)
(B)	: 184 mm (7.24 in) × 23 mm (0.91 in)
(C)	: 139 mm (5.47 in) × 23 mm (0.91 in)
(D)	: 39 mm (1.54 in) × 23 mm (0.91 in)
(E)	: 58 mm (2.28) × 23 (0.91) mm

Stick to the bracket.

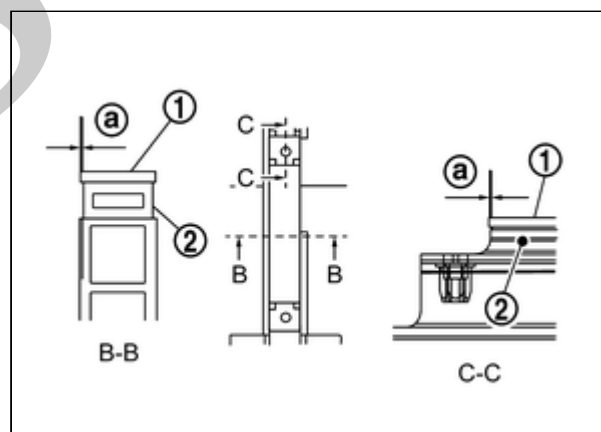

RPR-001999654-03-000360427

(1)	: EPT sealer
(2)	: Bracket
(a)	: 0.5 mm (0.020 in)

CAUTION:

Do not deviate from the position of EPR seal shown in the figure.

Hold EPT seal firmly with the ball of fingers.

3 Perform parts from (F) and (G) according to the following procedure.

WARNING:



To prevent electric shock, wear insulated protective gear.



a Peel EPT sealer from cross member of battery pack lower case.

b Wipe off any dirt or oil on the surface of cross member where EPT sealer is stuck.

c Cut EPT sealer (Nissan service parts) to the required length.

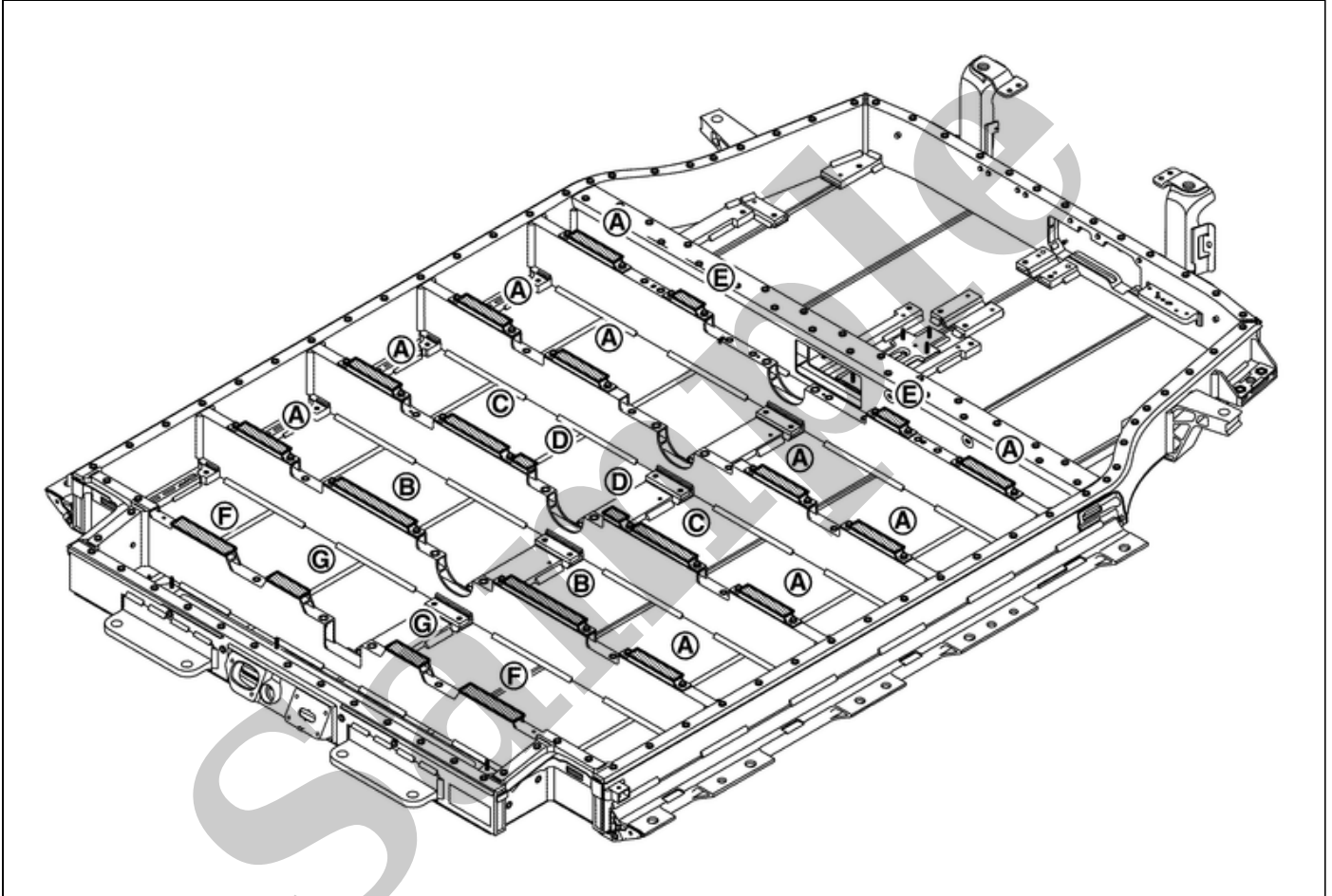

RPR-001999654-01-000402177

(E)	: 150 mm (5.91 in) × 26 mm (1.02 in)
(F)	: 100 mm (3.94 in) × 26 mm (1.02 in)

d Stick to cross member (B).

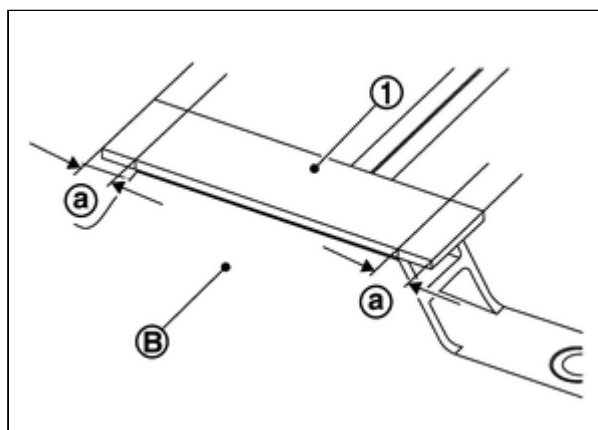

RPR-001999654-05-000360426

①	: EPT sealer
Ⓐ	: 10 mm (0.39 in)

CAUTION:

Do not deviate from the position of EPR seal shown in the figure.



NOTE:

- Since the work is done with insulated gloves, Ⓐ are used as dedicated handles.
- Bend handles Ⓐ down and stick them to the inclined parts.

Sample