

Your Ultimate Source for OEM Repair Manuals

FactoryManuals.net is a great resource for anyone who wants to save money on repairs by doing their own work. The manuals provide detailed instructions and diagrams that make it easy to understand how to fix a vehicle.

2009 FORD Ranger Super Cab OEM Service and Repair Workshop Manual

[Go to manual page](#)

Refer to: [Roof Opening Panel Frame](#)(501-17 Roof Opening Panel, Removal and Installation).

9. Remove the side curtain air bags.

Refer to: [Side Curtain Airbag - SuperCrew](#)(501-20B Supplemental Restraint System, Removal and Installation).

10. Remove the roof ditch sealer.

Use the General Equipment: Hot Air Gun

Use the General Equipment: Scraper for Straight Edges

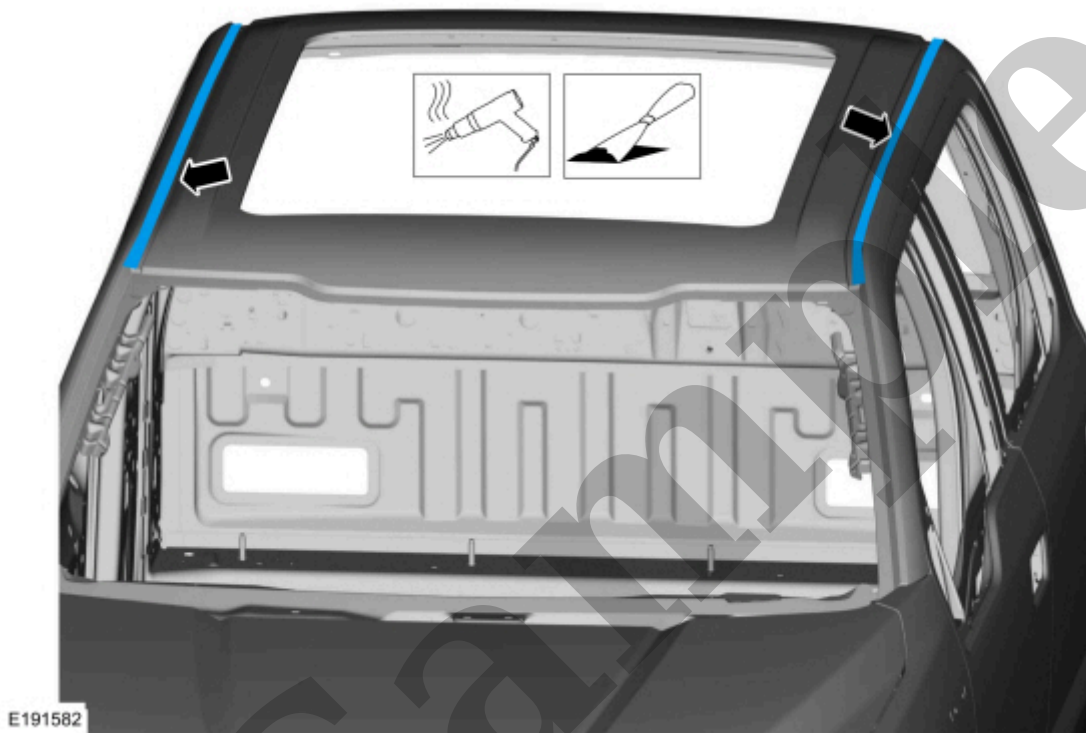

[Click here to learn about symbols, color coding, and icons used in this manual.](#)

11. Remove the front header SPR (self-piercing rivet) fasteners.

Use the General Equipment: Self-Piercing Rivet (SPR) Remover/Installer

Use the General Equipment: Belt Sander

[Click here to learn about symbols, color coding, and icons used in this manual.](#)

13. Carefully cut the roof

outer panel only

in the area shown (inboard on the roof ditch, both sides).

Use the General Equipment: Air Body Saw

Use the General Equipment: Spherical Cutter

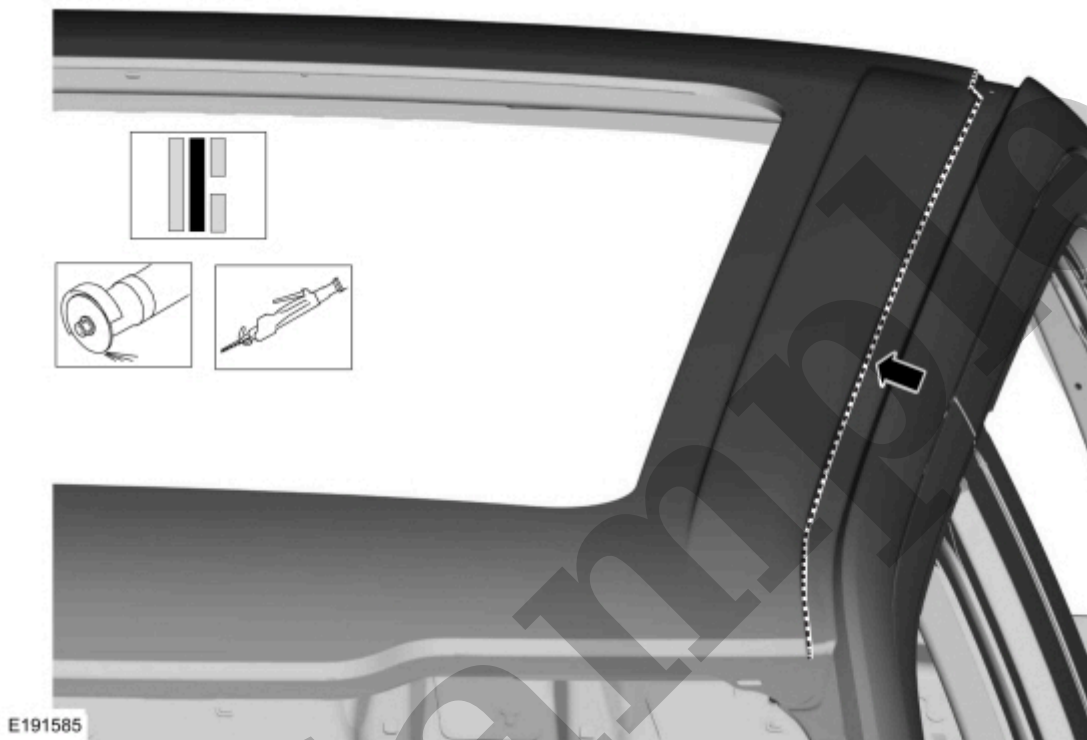

[Click here to learn about symbols, color coding, and icons used in this manual.](#)

14. Separate the foam and adhesive between the body and roof panel leaving as much foam intact as possible on the roof supports.

Use the General Equipment: Knife

16. With the help of an assistant remove the roof panel.

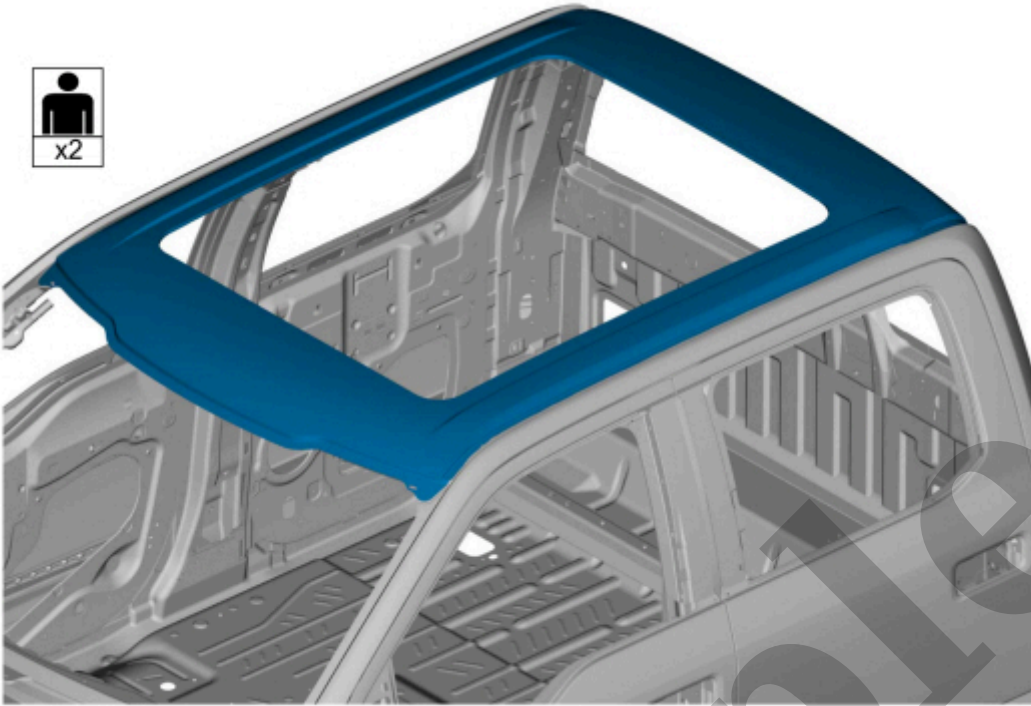

E191588

[Click here to learn about symbols, color coding, and icons used in this manual.](#)

17. **NOTE**

Carefully grind the area smooth removing remaining portions of the factory laser weld. use caution to avoid thinning of the metal.

Using a grinder or air chisel, carefully remove the remaining portion of the roof panel flange and laser weld bead.

Use the General Equipment: Grinder

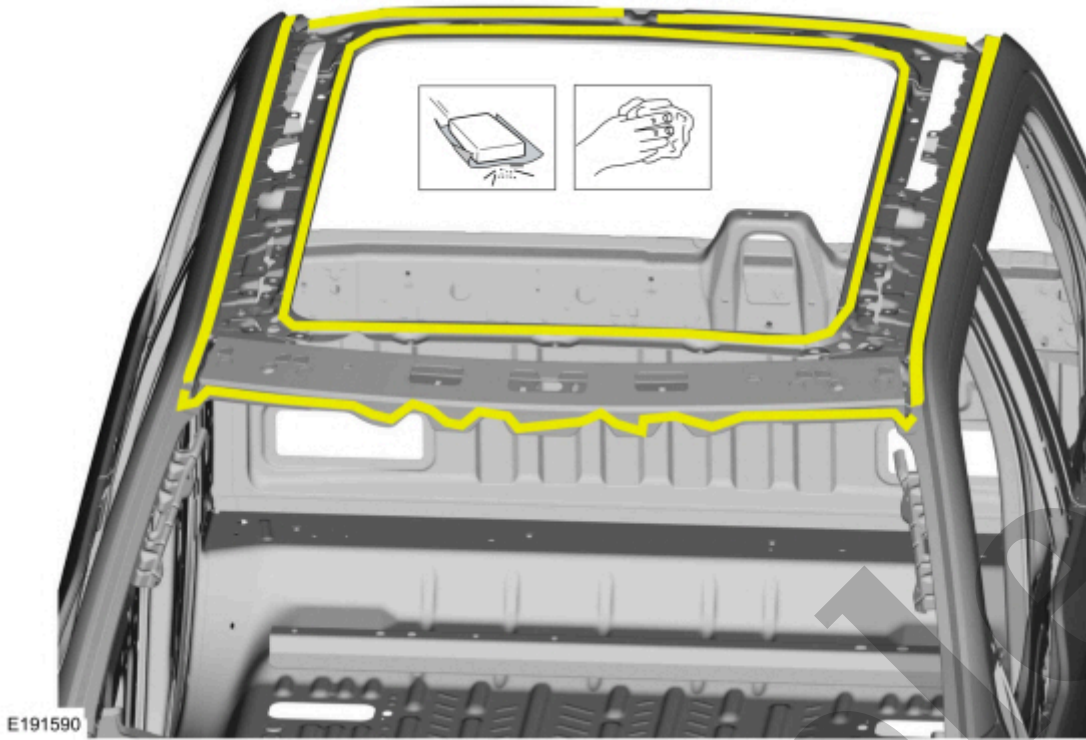

[Click here to learn about symbols, color coding, and icons used in this manual.](#)

3. Sand to remove any remaining adhesive in the rear flange and clean.

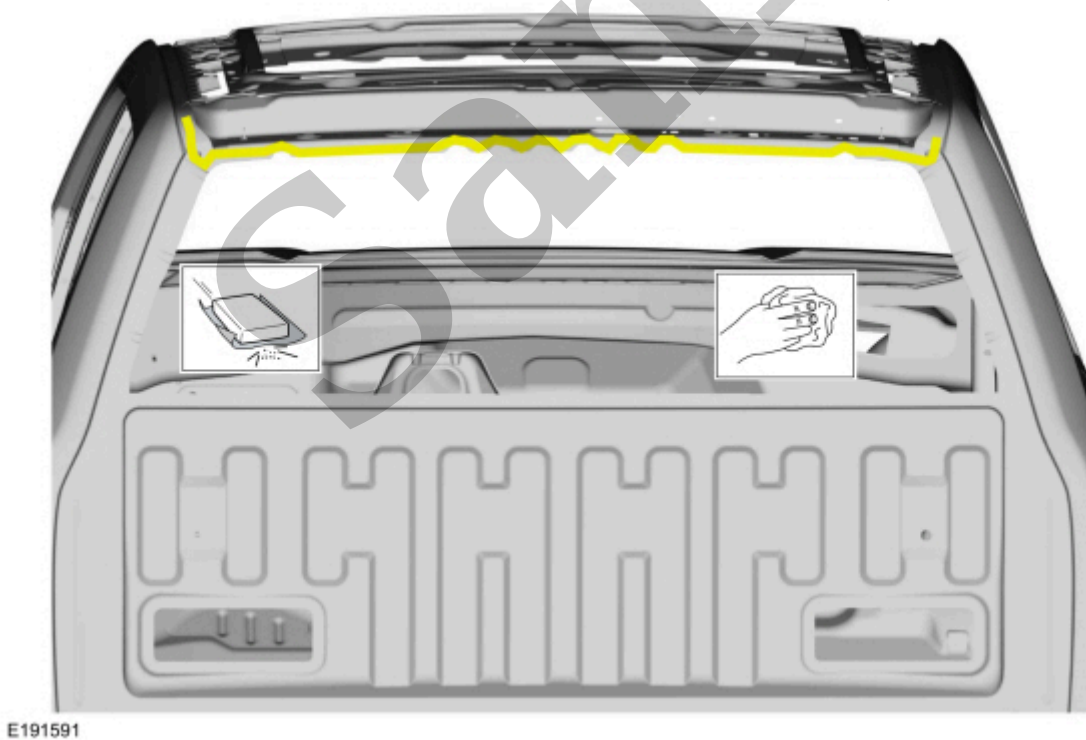

[Click here to learn about symbols, color coding, and icons used in this manual.](#)

4. Sand to remove the e-coat and clean the roof panel mating surface using 80 grit sandpaper.

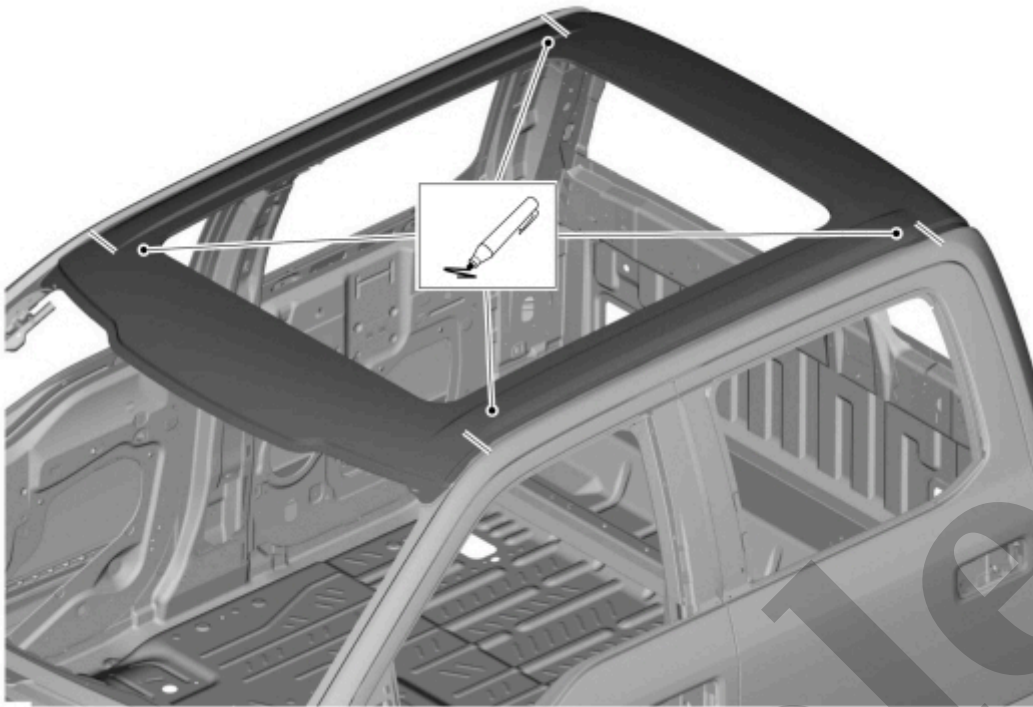

E191593

[Click here to learn about symbols, color coding, and icons used in this manual.](#)

7. With the help of an assistant, remove the roof outer panel.

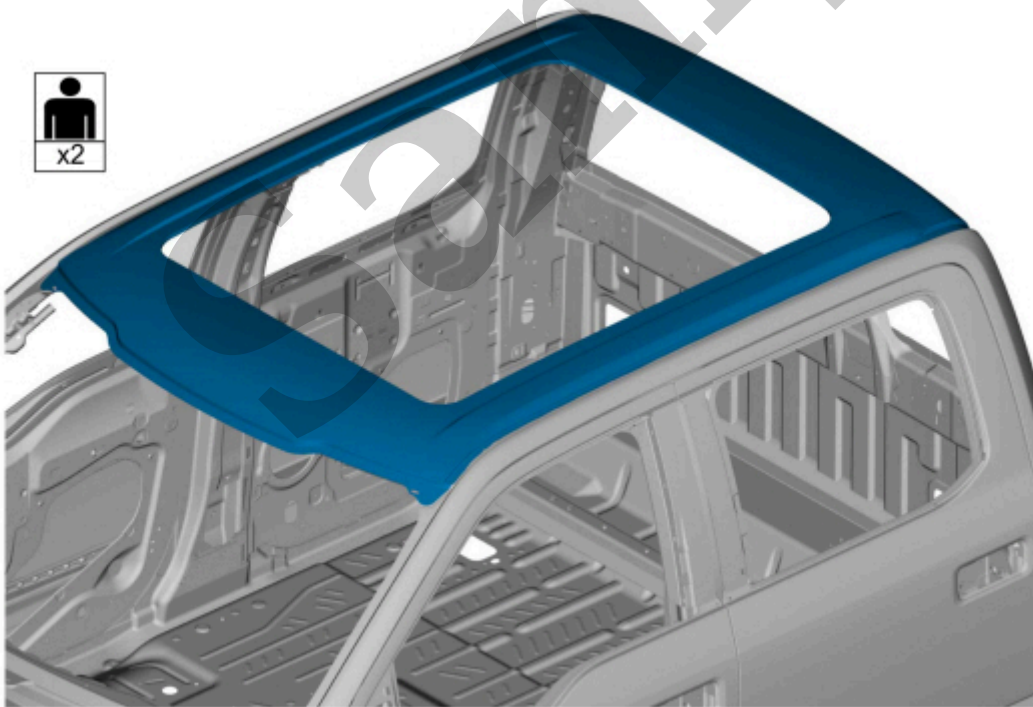

E191588

[Click here to learn about symbols, color coding, and icons used in this manual.](#)

8. Apply adhesive to the roof opening reinforcement, front header and roof ditch area mating surfaces.

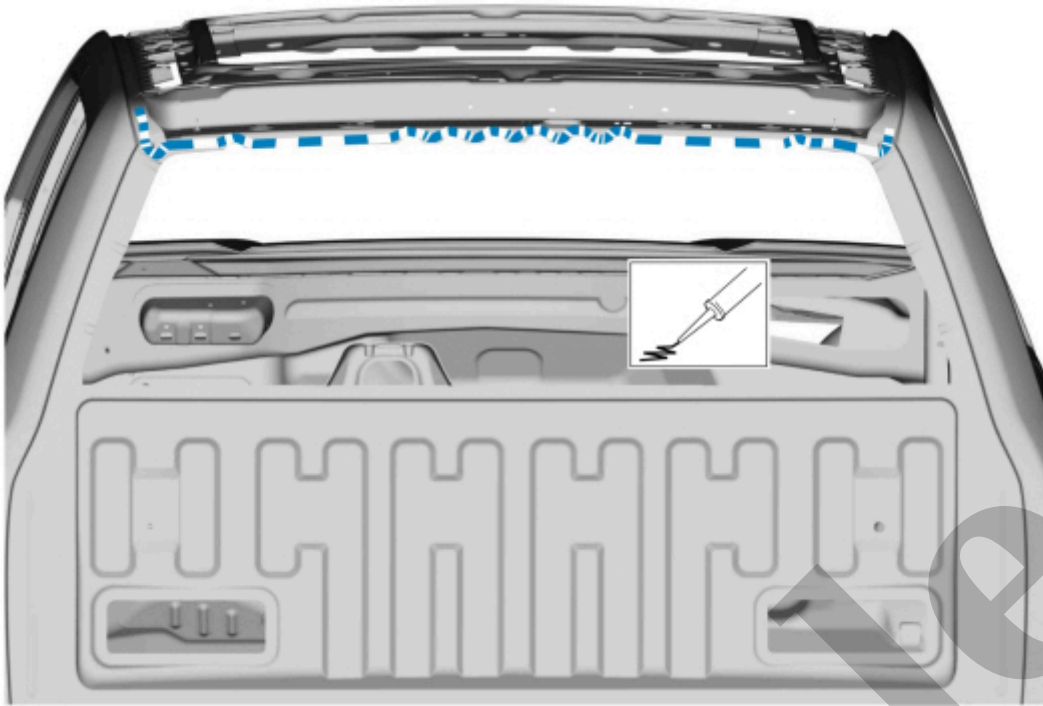

E191595

[Click here to learn about symbols, color coding, and icons used in this manual.](#)

10. With the help of an assistant, install the roof outer panel.

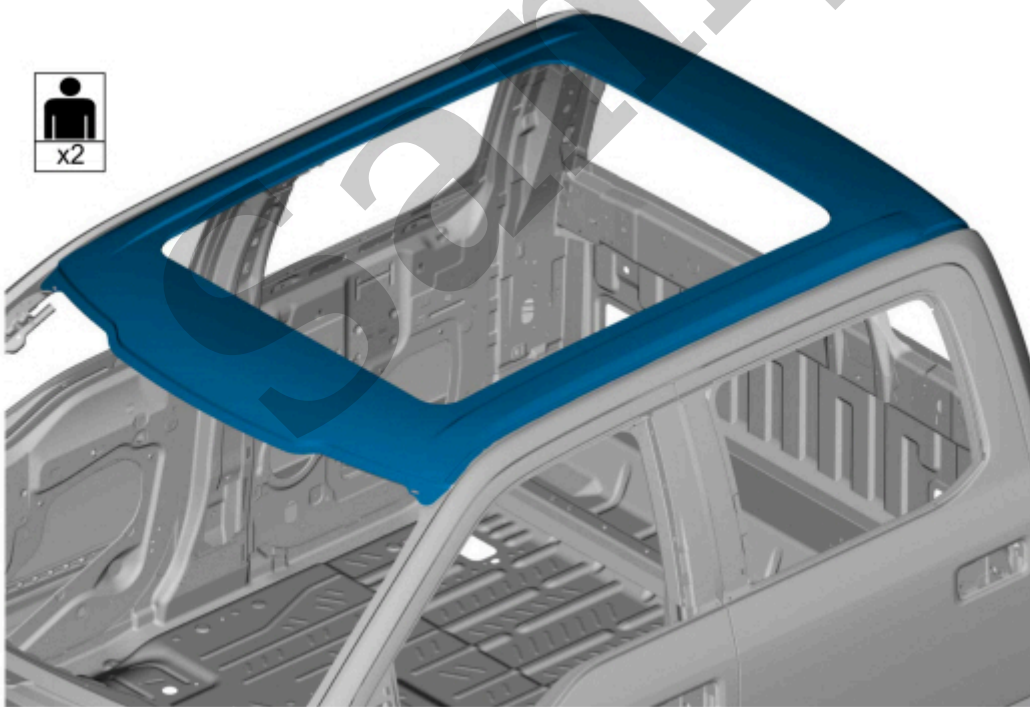

E191588

[Click here to learn about symbols, color coding, and icons used in this manual.](#)

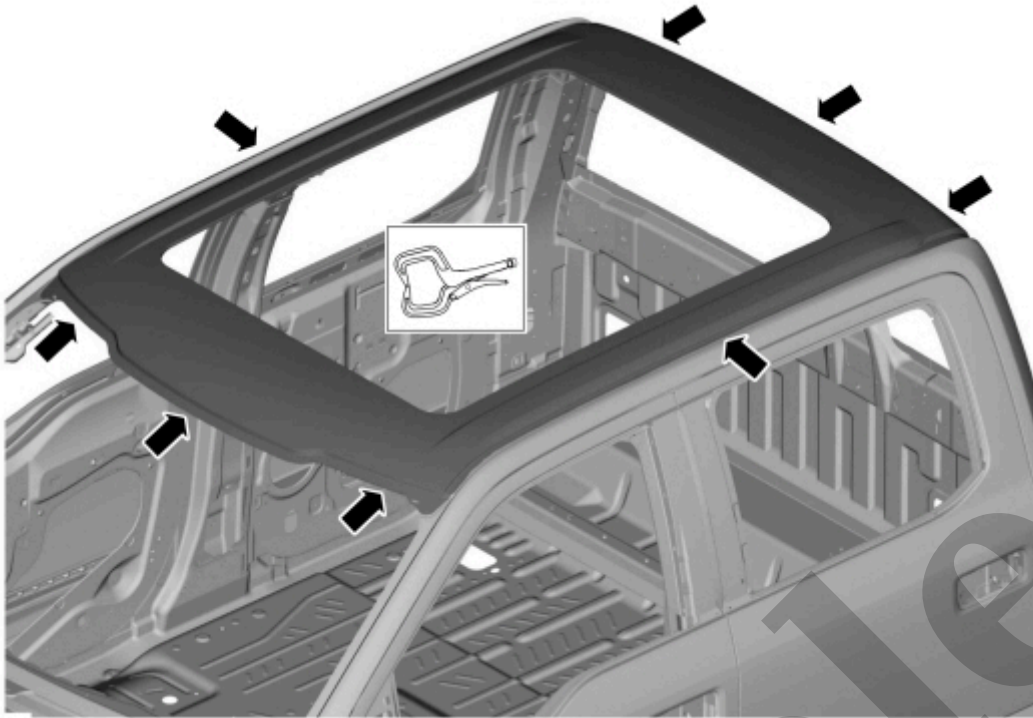

E191597

[Click here to learn about symbols, color coding, and icons used in this manual.](#)

13. NOTE

SPR (self-piercing rivet) fasteners may not be placed directly over original SPR (self-piercing rivet) location. They must be placed adjacent to original location matching original quantity.

NOTE

Solid rivets may be used in place of SPR (self-piercing rivet) fasteners in the original SPR (self-piercing rivet) location after enlarging hole to 6.5 mm.

Install the fasteners.

Item	SPR (self-piercing rivet) Number	SPR (self-piercing rivet) Code	Henrob®, Car-OLiner®, CMO®, Chief®, Spanesi®, Wielander and Schill® Mandrel	Pro-Spot® Mandrel	Blind Rivet	Solid Rivet	Rivnut®
1	W708713-S900	AS	DP10-200H	SA-0400/SA-0401	-	W790376-S900	-

Solid or blind rivets may be used in place of SPR (self-piercing rivet) fasteners in the original SPR (self-piercing rivet) location after enlarging hole to 6.5 mm.

Install the fasteners.

Item	SPR (self-piercing rivet) Number	SPR (self-piercing rivet) Code	Henrob®, Car-OLiner®, CMO®, Chief®, Spanesi®, Wielander and Schill® Mandrel	Pro-Spot® Mandrel	Blind Rivet	Solid Rivet	Rivnut®
1	W709559-S900	AT	DZ07-000/H	SA-0400/SA-0401	-	W790376-S900	-
2	W710246-S900	BN	DP10-200/H	SA-0400/SA-0401	-	W790376-S900	-
3	W708713-S900	AS	DZ09-025/H	SA-0400/SA-0401	-	W790376-S900	-

Refer to: [Joining Techniques](#)(501-25 Body Repairs - General Information, General Procedures).

Use the General Equipment: Self-Piercing Rivet (SPR) Remover/Installer

Use the General Equipment: Blind Rivet Gun

[Click here to learn about symbols, color coding, and icons used in this manual.](#)

17. Mask off the windshield glass channel.

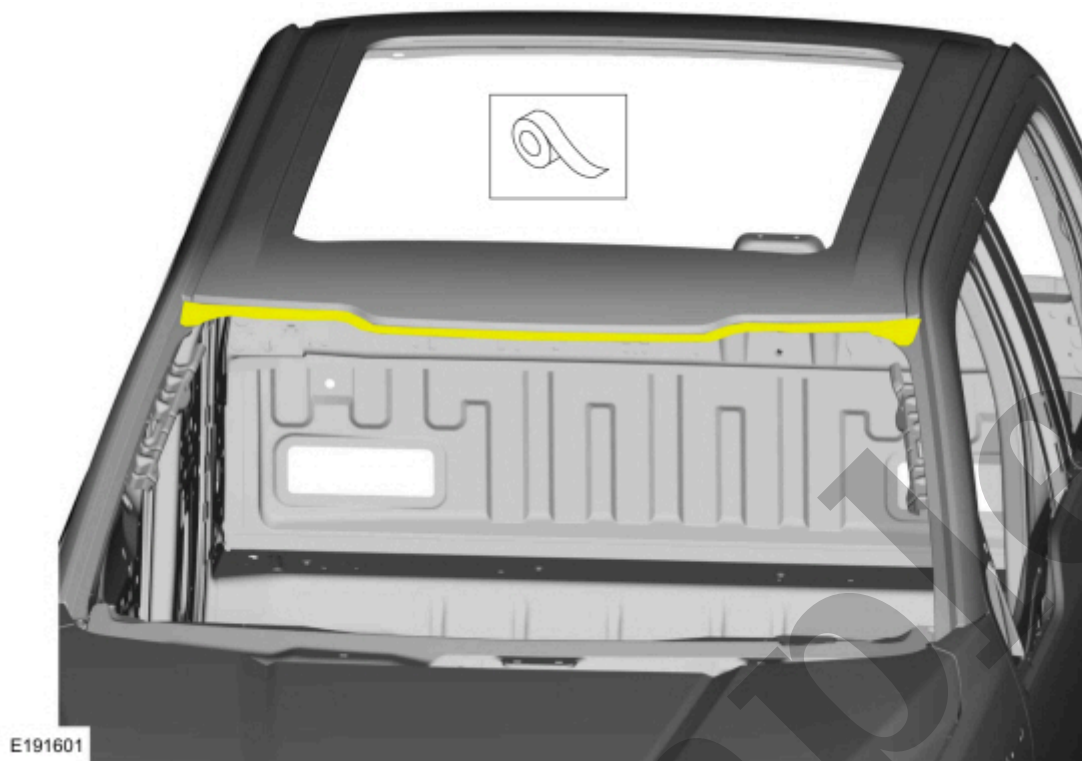

[Click here to learn about symbols, color coding, and icons used in this manual.](#)

18. Apply roof ditch sealer following manufacturer's directions.

Material : Roof Ditch Sealer / 3M™ 08307, LORD Fusor® 129