

Your Ultimate Source for OEM Repair Manuals

FactoryManuals.net is a great resource for anyone who wants to save money on repairs by doing their own work. The manuals provide detailed instructions and diagrams that make it easy to understand how to fix a vehicle.

2009 FORD C-Max OEM Service and Repair Workshop Manual

[Go to manual page](#)

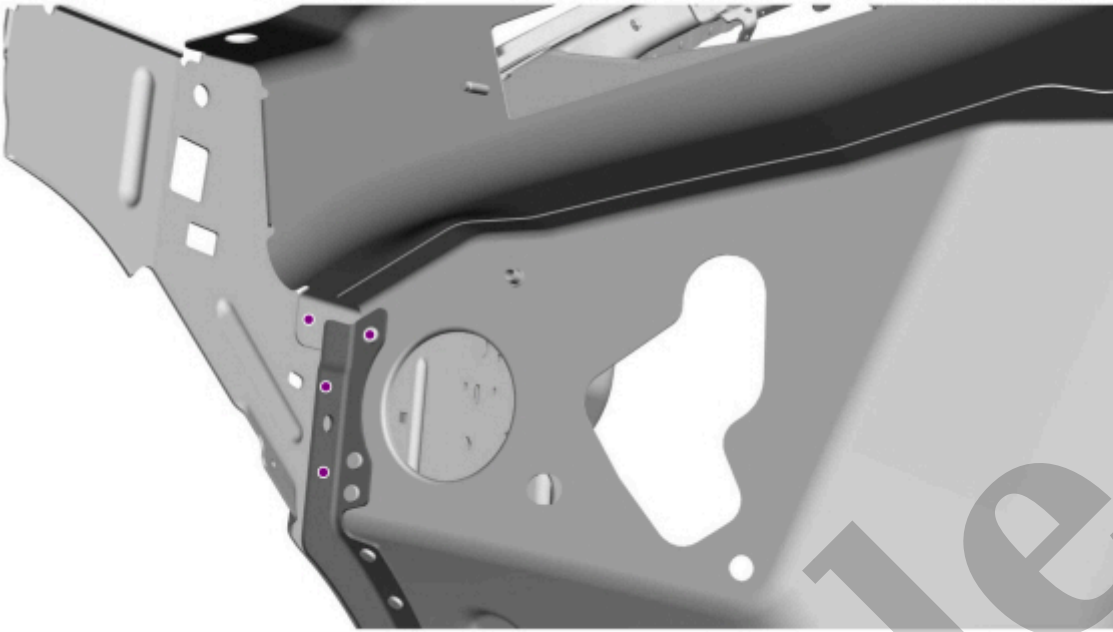

E337994

[Click here to learn about symbols, color coding, and icons used in this manual.](#)

19. Remove the SPR (self-piercing rivet) fasteners on the RH (right-hand) side passenger compartment.

Use the General Equipment: Self-Piercing Rivet (SPR) Remover/Installer

Use the General Equipment: Belt Sander

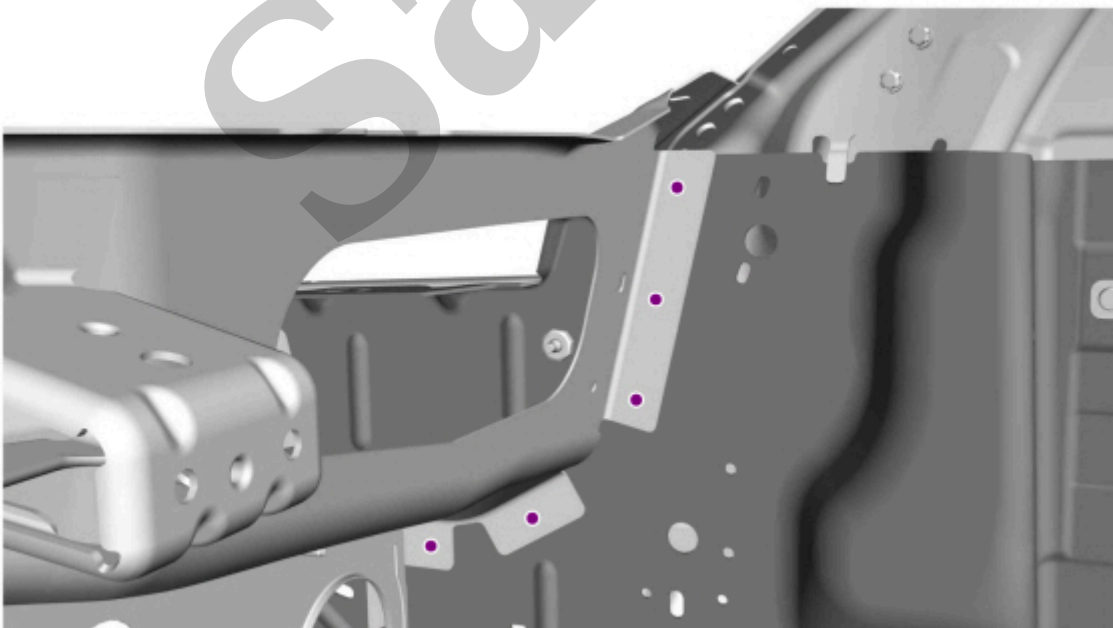

E337993

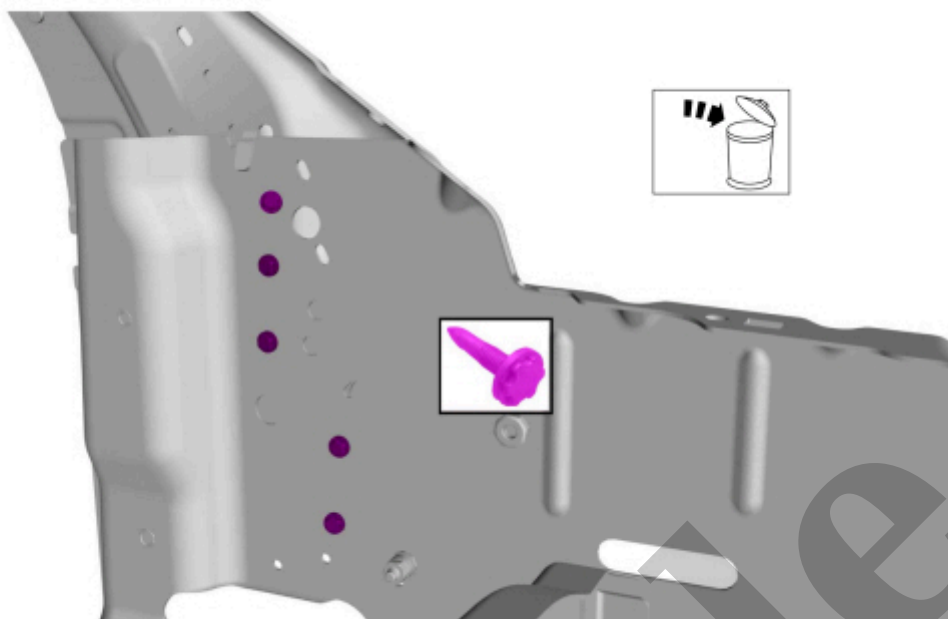

E338305

[Click here to learn about symbols, color coding, and icons used in this manual.](#)

23. Remove the SPR (self-piercing rivet) fasteners.

Use the General Equipment: Belt Sander

Use the General Equipment: Self-Piercing Rivet (SPR) Remover/Installer

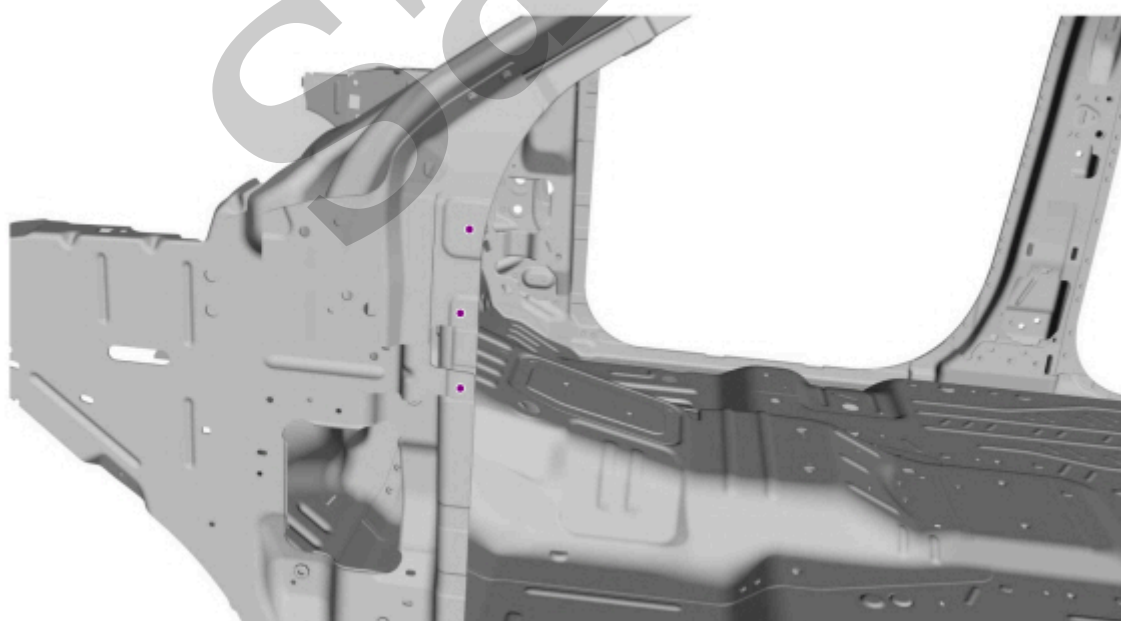

E338306

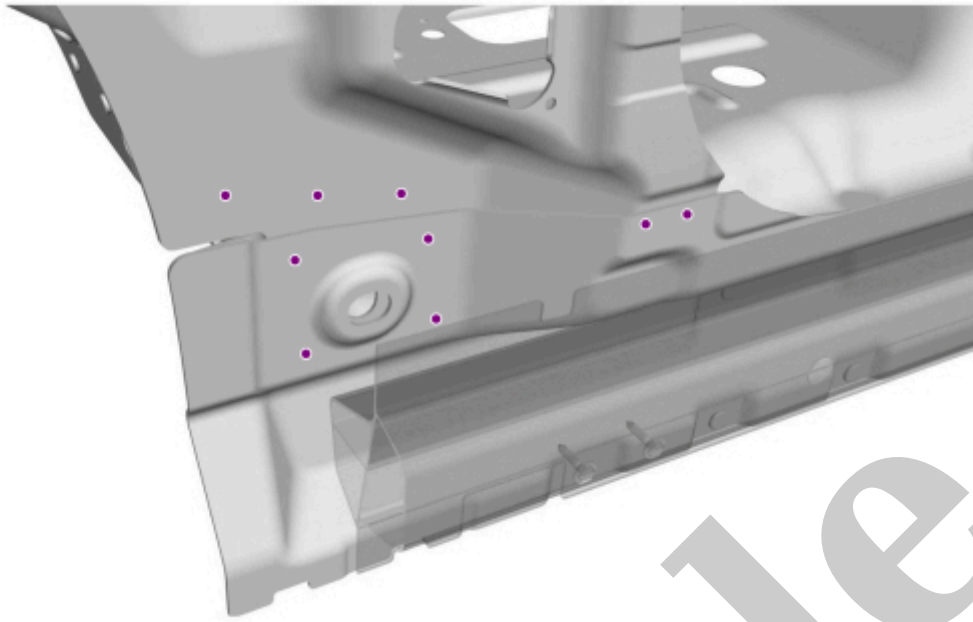

E338308

[Click here to learn about symbols, color coding, and icons used in this manual.](#)

26. Break the adhesive bond and remove the cowl side panel.

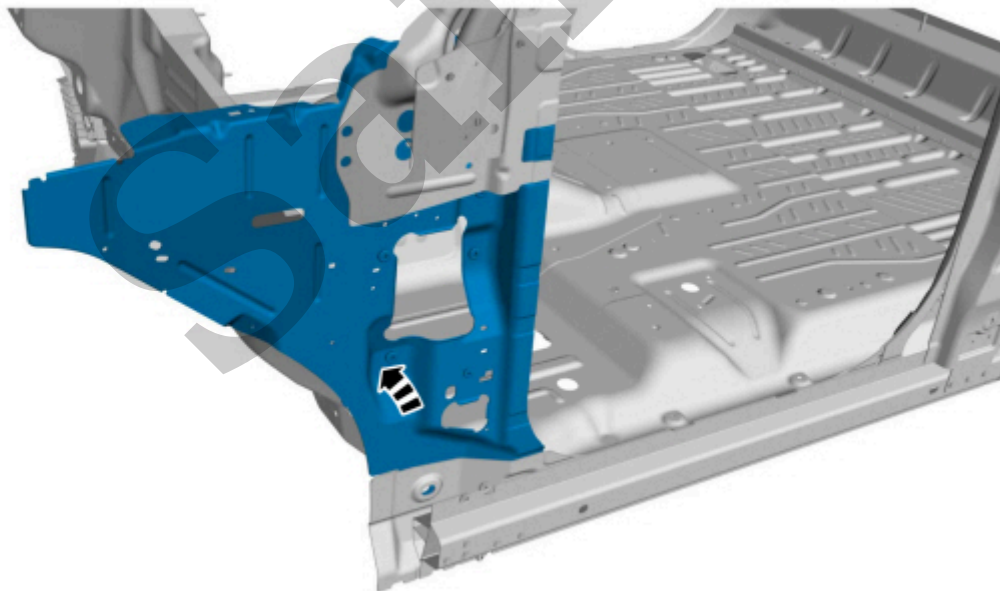

E338309

[Click here to learn about symbols, color coding, and icons used in this manual.](#)

Installation

3. Apply adhesive.

Material : Metal Bonding Adhesive / TA-1, TA-1-B, 3M™ 08115, LORD Fusor® 108B, Henkel Teroson EP 5055

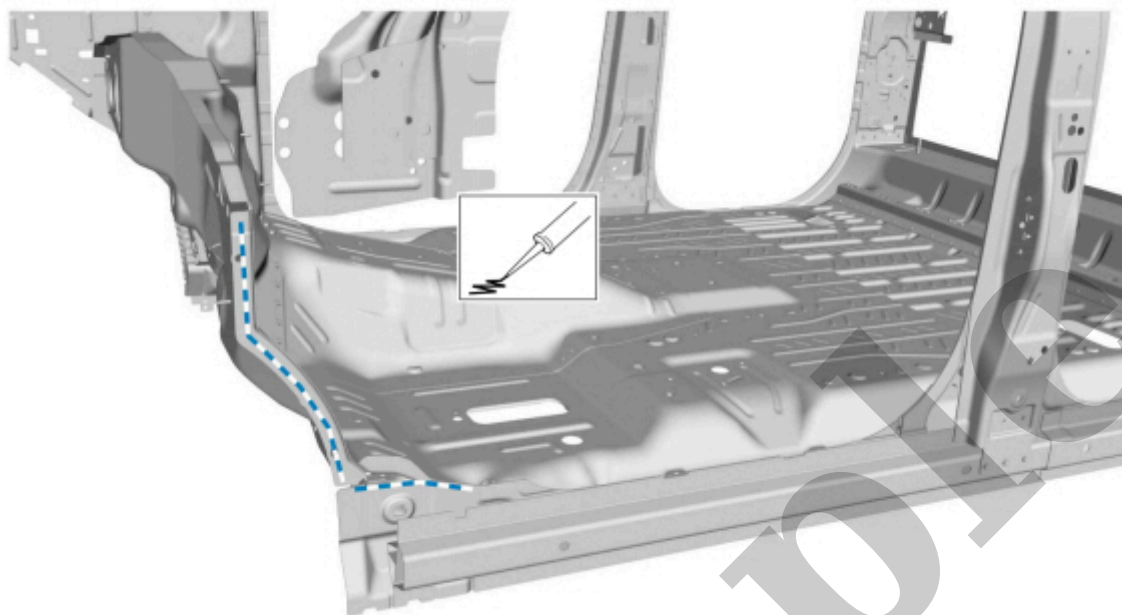

E338312

[Click here to learn about symbols, color coding, and icons used in this manual.](#)

4. Install, properly position and clamp the cowl side panel.

Use the General Equipment: Locking Pliers

6. Install the fasteners.

| Item | SPR (self-piercing rivet) Number | SPR (self-piercing rivet) Code | Henrob® Car-O-Liner®, CMO®, Chief®, Spanesi® Wielande and Schill® Mandrel | Pro-Spot® Mandrel | Blind Rivet | Solid Rivet | Rivnut® |
|------|----------------------------------|--------------------------------|---|-------------------|---------------|-------------|---------|
| 1 | - | - | - | - | W702512-S900C | - | - |
| 2 | - | - | - | - | W708777-S900C | - | - |

Use the General Equipment: Blind Rivet Gun

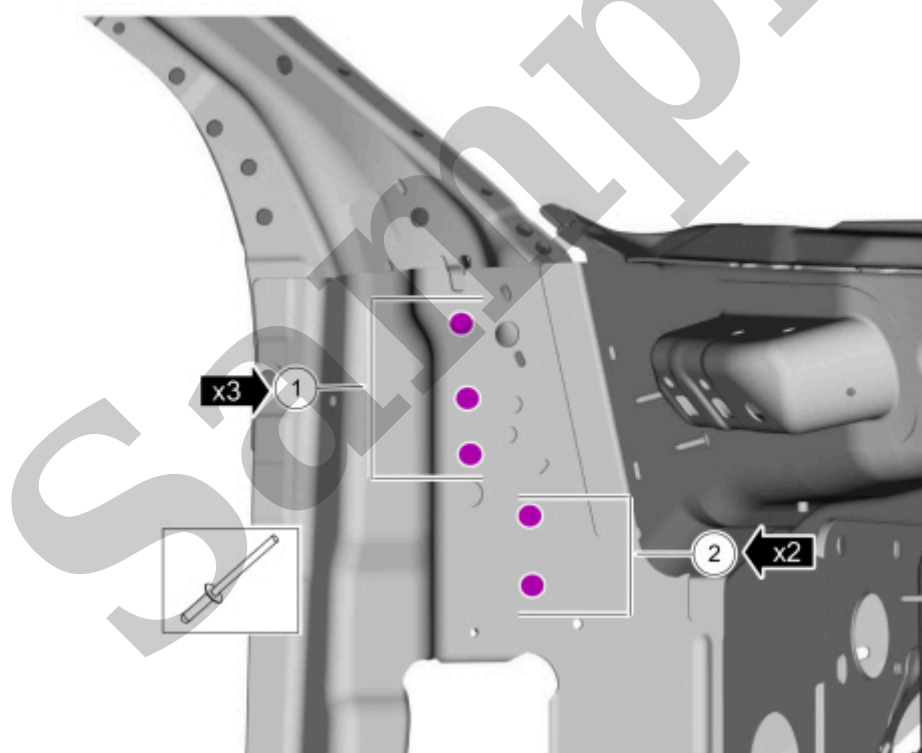

E192617

[Click here to learn about symbols, color coding, and icons used in this manual.](#)

7. Install the cross-car beam bracket and bolts.

Torque : 18 lb.ft (25 Nm)

Do not install SPR (self-piercing rivet) fasteners directly in old SPR (self-piercing rivet) fastener location. SPR (self-piercing rivet) fasteners must be installed adjacent to the original location matching original quantity.

Drill for fasteners.

Use the General Equipment: 6.5 mm Drill Bit

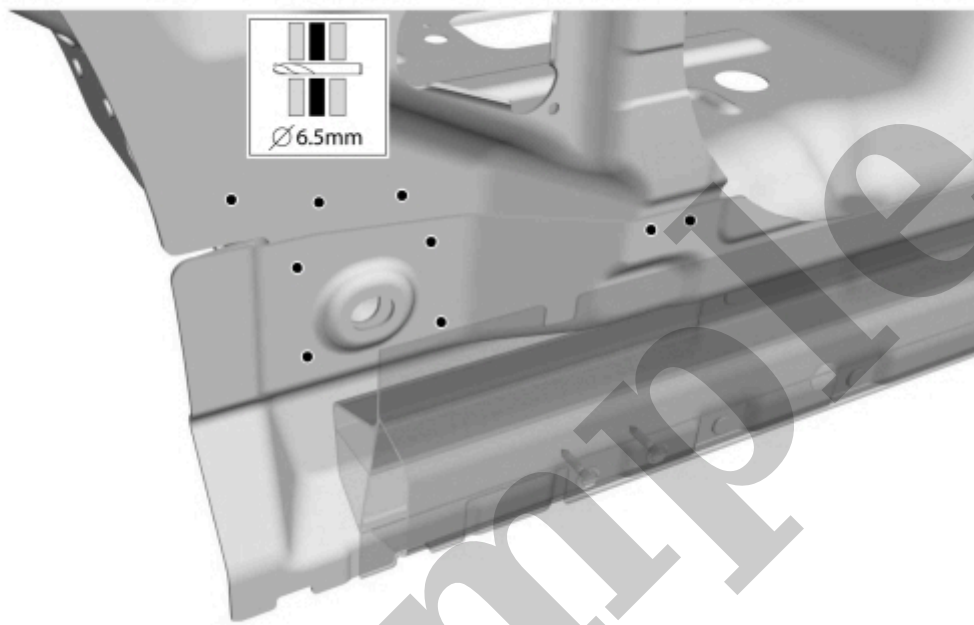

E341326

[Click here to learn about symbols, color coding, and icons used in this manual.](#)

9. **NOTE**

Do not install SPR (self-piercing rivet) fasteners directly in old SPR (self-piercing rivet) fastener location. SPR (self-piercing rivet) fasteners must be installed adjacent to the original location matching original quantity.

NOTE

Solid rivets or blind rivet fasteners may be used in place of SPR (self-piercing rivet) fasteners after enlarging existing holes to 6.5 mm.

Install the fasteners.

Install the fasteners.

| Item | SPR (self-piercing rivet) Number | SPR (self-piercing rivet) Code | Henrob® Car-O-Liner®, CMO®, Chief®, Spanesi® Wielande and Schill® Mandrel | Pro-Spot® Mandrel | Blind Rivet | Solid Rivet | Rivnut® |
|------|----------------------------------|--------------------------------|---|-------------------|--------------|-------------|---------|
| 1 | W710246-S900 | BN | DP10-200/H | SA-0400/SA-0402 | W708777-S901 | - | - |

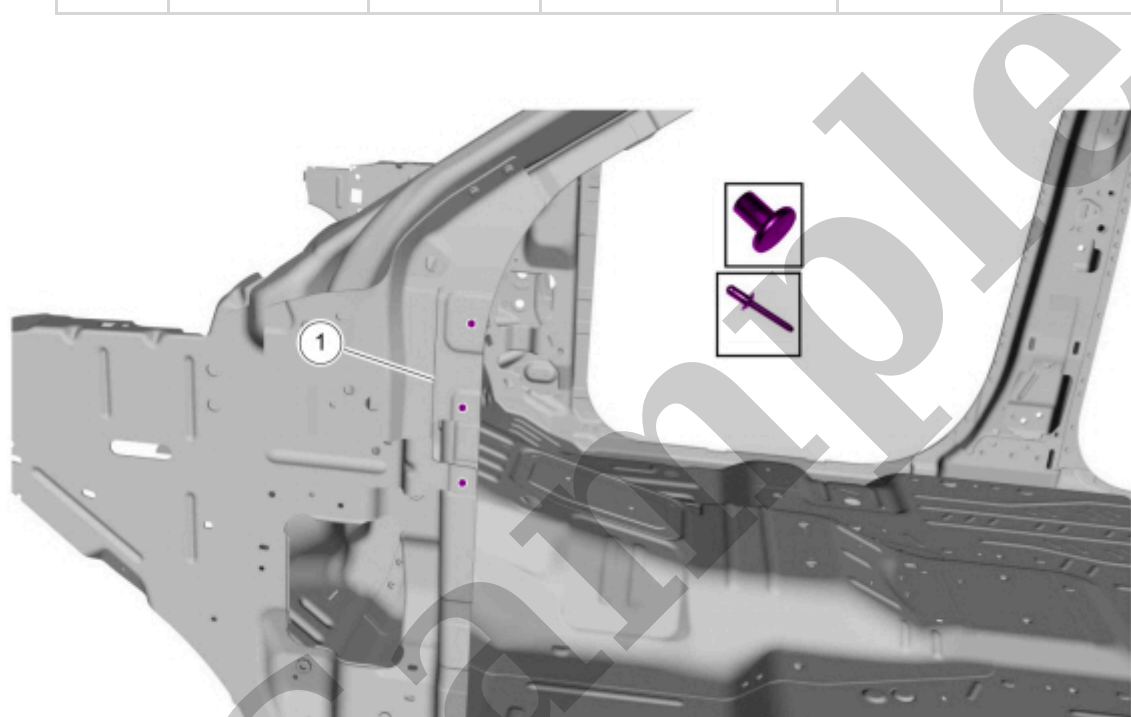

E338316

[Click here to learn about symbols, color coding, and icons used in this manual.](#)

11. NOTE

Do not install SPR (self-piercing rivet) fasteners directly in old SPR (self-piercing rivet) fastener location. SPR (self-piercing rivet) fasteners must be installed adjacent to the original location matching original quantity.

Drill for fasteners.

Use the General Equipment: 6.5 mm Drill Bit

| | | | | | | | |
|---|---|---|---|---|---------------|---|---|
| 1 | - | - | - | - | W707638-S900C | - | - |
|---|---|---|---|---|---------------|---|---|

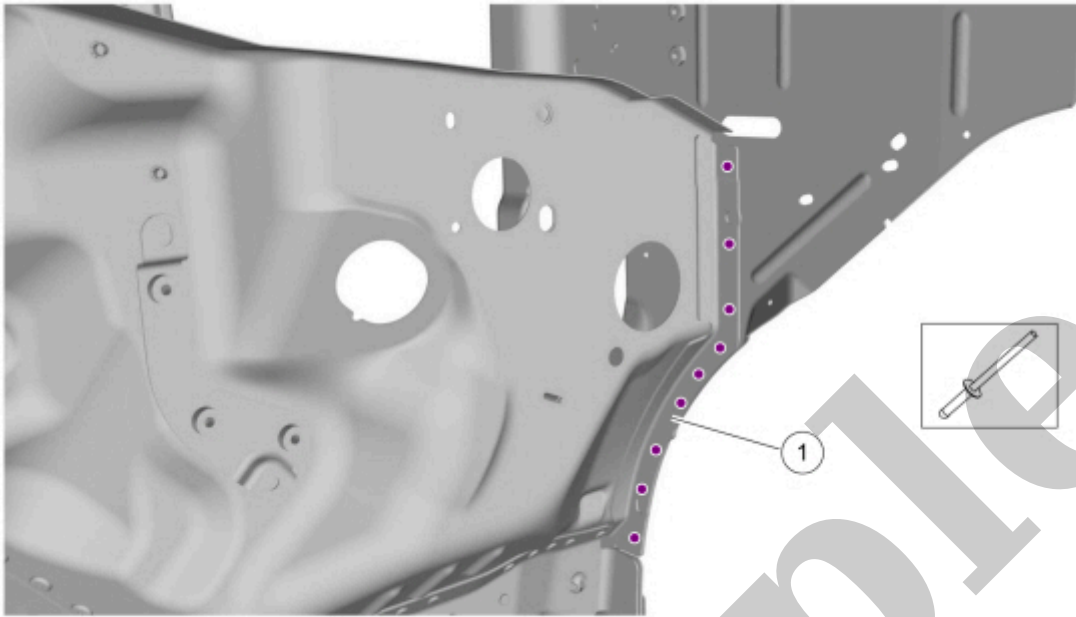

E338315

[Click here to learn about symbols, color coding, and icons used in this manual.](#)

13. Sand the replacement panel in area where adhesive is to be applied.

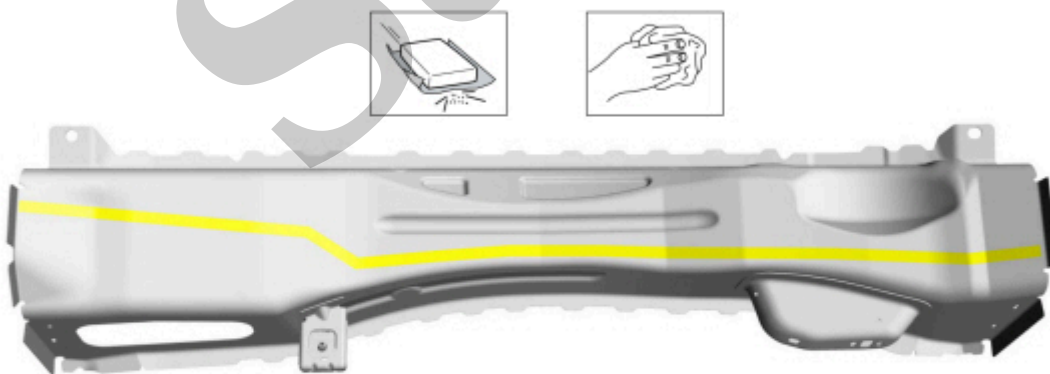

E337996

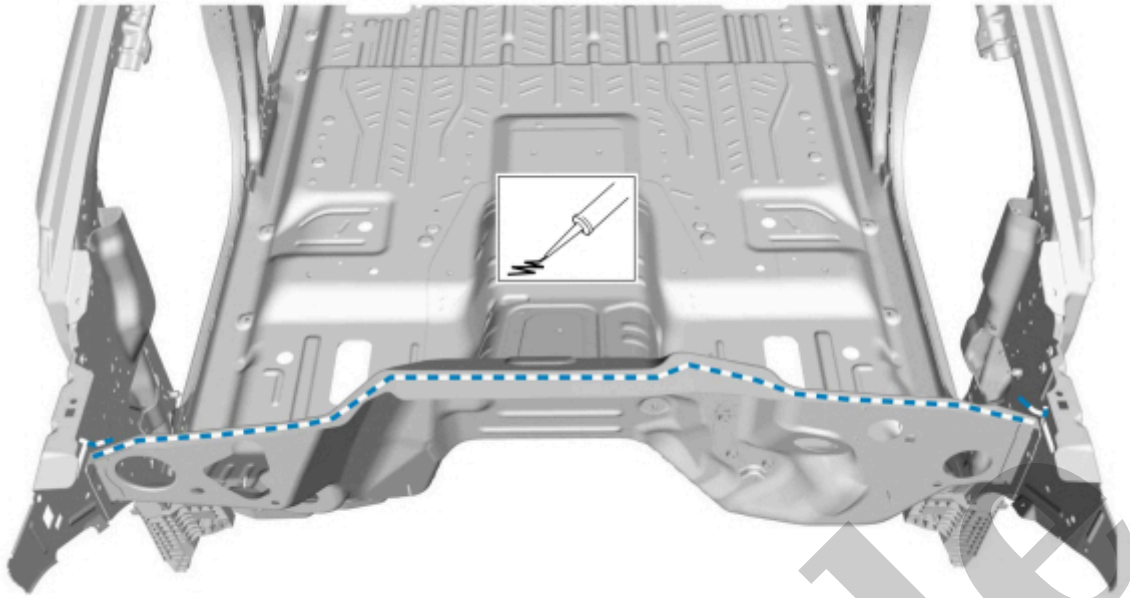

E337998

[Click here to learn about symbols, color coding, and icons used in this manual.](#)

16. Install, properly position and clamp the cowl panel.

Use the General Equipment: Locking Pliers

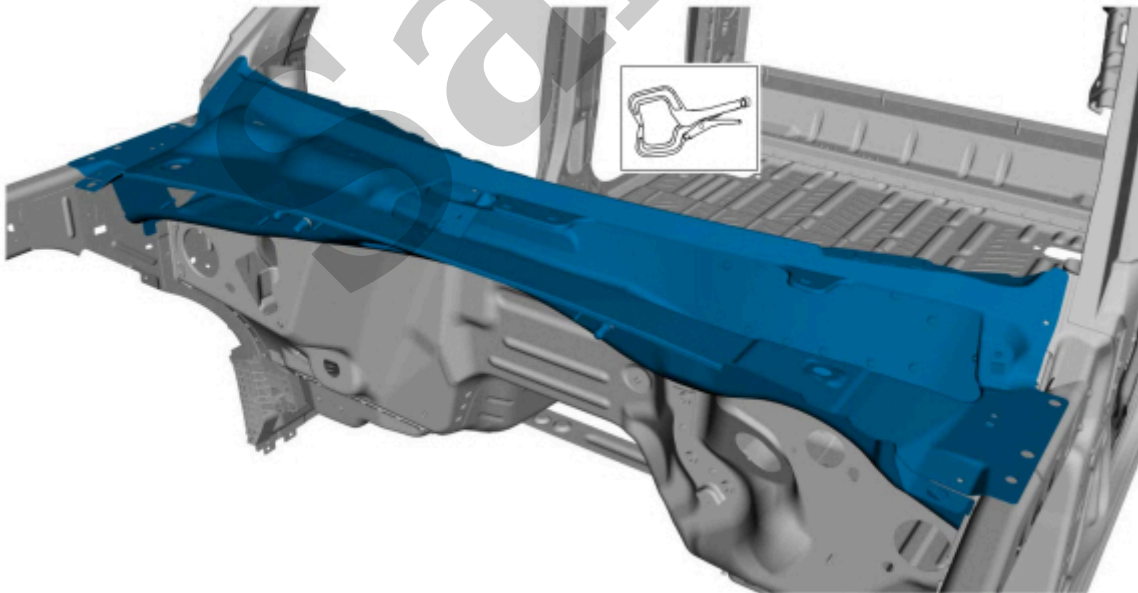

E337999

[Click here to learn about symbols, color coding, and icons used in this manual.](#)