

# Your Ultimate Source for OEM Repair Manuals

FactoryManuals.net is a great resource for anyone who wants to save money on repairs by doing their own work. The manuals provide detailed instructions and diagrams that make it easy to understand how to fix a vehicle.

## 2008 Jeep LIBERTY Service Manual

[Go to manual page](#)

55. Remove the two retainers securing the manual park release cable to the rear of the cylinder head cover (left side).
56. Remove the left and right half shafts (Refer to Differential and Driveline/SHAFTS, Axle/Drive/Half/Removal and Installation).
57. Detach the transmission wire harness retainers from the bottom of the intake manifold and position aside the wire harness.
58. Remove the transmission with transfercase (Refer to Transmission and Transfer Case/Automatic/Removal and Installation)(Refer To List 6).
59. Remove the bolts securing the A/C lines to the shock tower.

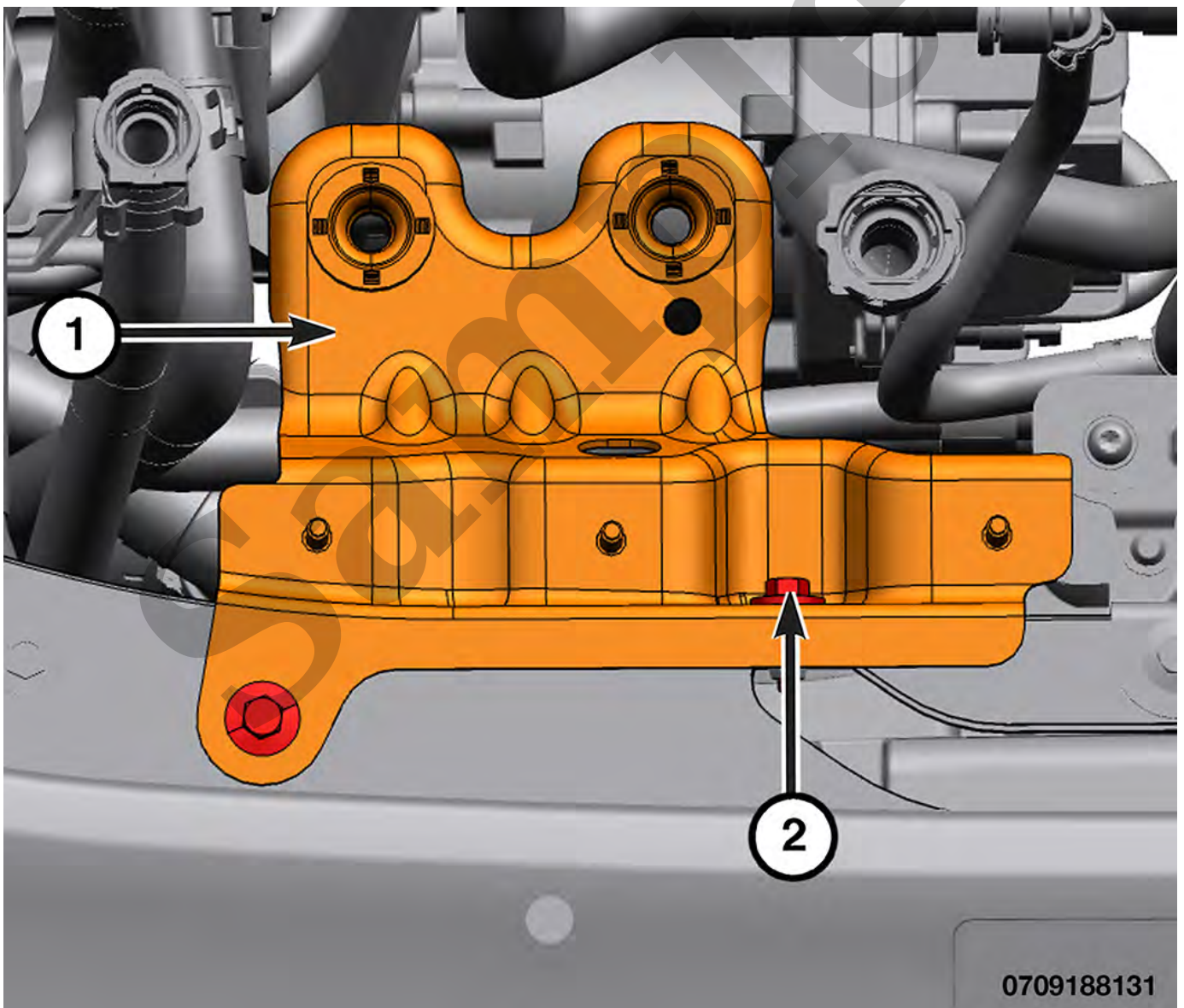

1 - Coolant Bottle Bracket

0709188131

4. Install the left lower engine mount bolts and tighten to the proper torque specifications.

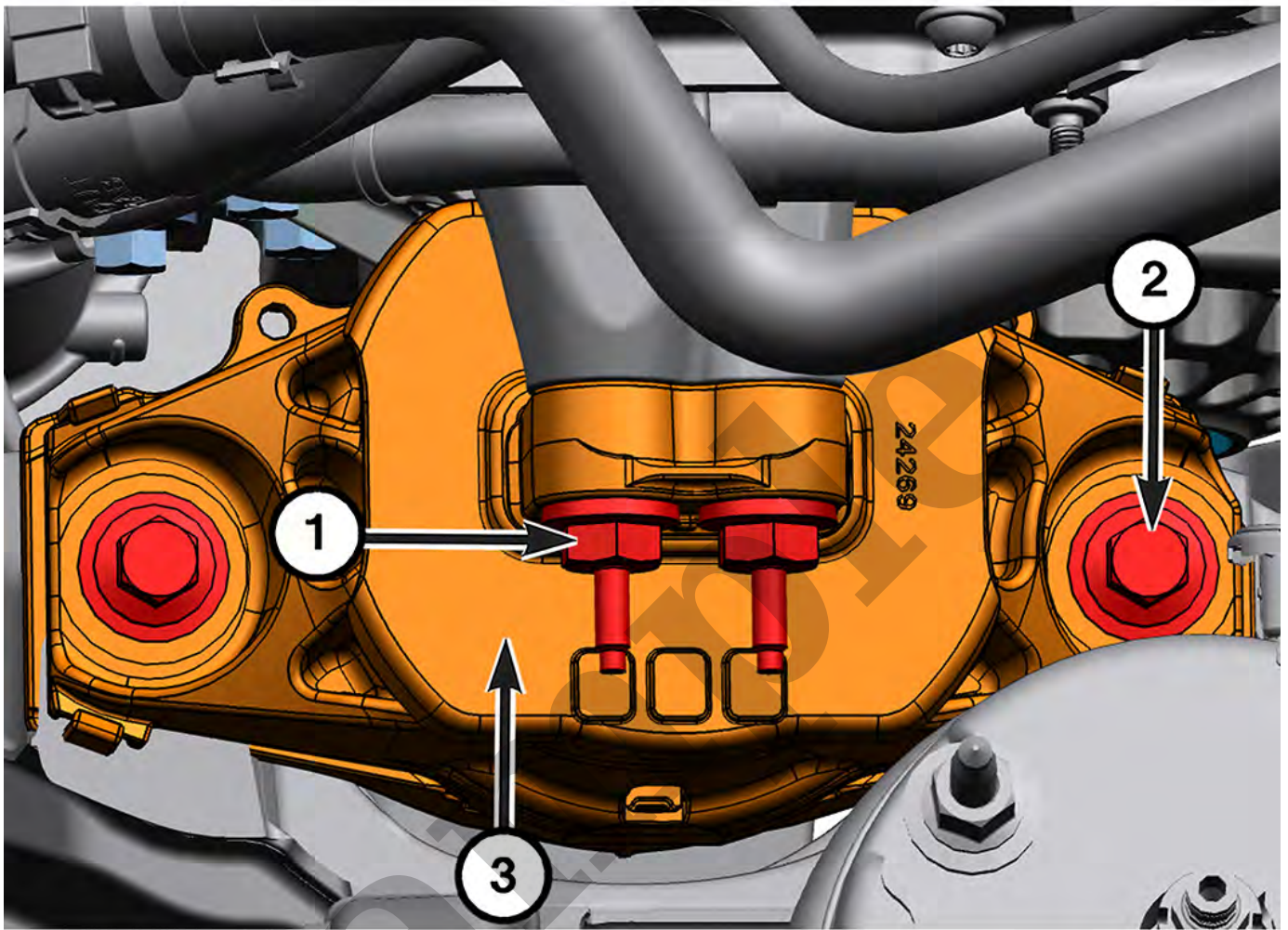

0912186708

1 - Engine Mount Stud Bolts
2 - Engine Mount Bolts
3 - Engine Mount

5. Install the right lower engine mount bolts and tighten to the proper torque specifications.

6. Remove the engine hoist and load-lifting lifting sling from the engine.

7. Connect the coolant hose on the right shock tower.

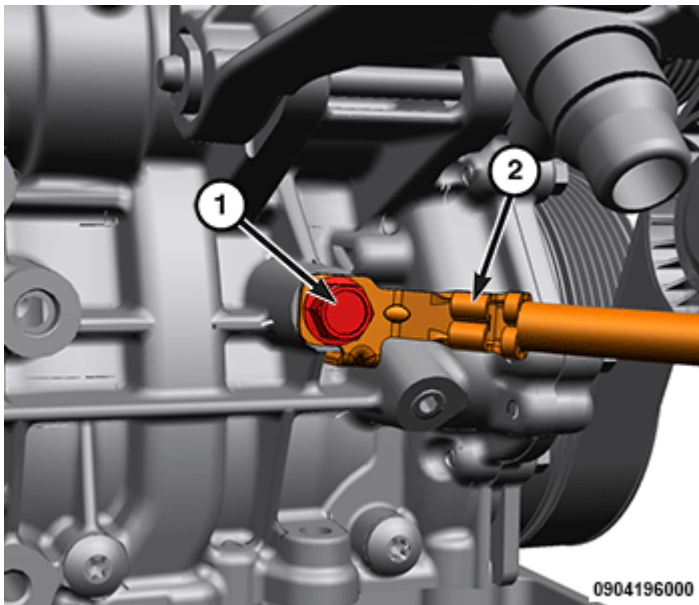

1 - Ground Cable Bolt
2 - Ground Cable

20. Install the ground cable and tighten bolt to the proper torque specification.
21. Install the front differential wire harness retainer to the front differential support bracket.
22. Attach the two wire harness retainers to the body (right side).
23. Connect the engine wire harness connectors under the PCM.



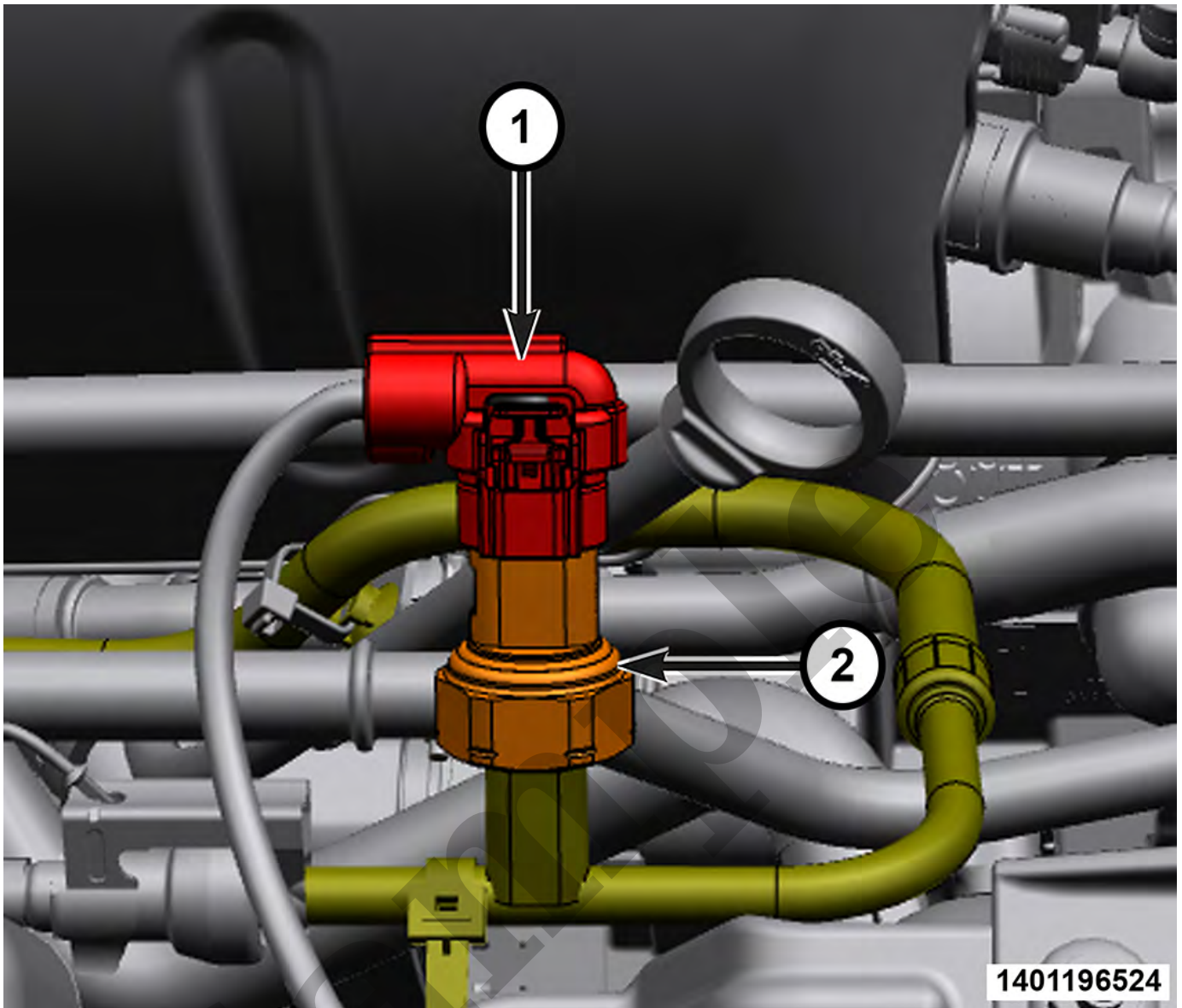

1 - Fuel Pressure Sensor Wire Harness Connector

2 - Fuel Pressure Sensor

32. Connect the fuel pressure sensor wire harness connector.
33. Install the transmission vent hose retainers
34. Install the hood ([Refer to Body/Hood/HOOD/Removal and Installation](#)).
35. Install the battery pressurized coolant bottle ([Refer to Electrified Powertrain System/Battery Cooling/RESERVOIR/Removal and Installation](#)).
36. Install the low temp pressurized coolant bottle ([Refer to Engine/Low Temperature Cooling System/BOTTLE, Coolant/Removal and Installation](#)).

## LEFT ENGINE MOUNT

CALLOUT	DESCRIPTION	SPECIFICATION	COMMENTS
1	Engine Mount Bracket Bolts	63 N·m (46 Ft. Lbs.)	—
2	Engine Mount Heat Shield Nuts	11 N·m (8 Ft. Lbs.)	—
3	Engine Mount Stud Bolts	63 N·m (46 Ft. Lbs.)	—
4	Engine Mount Bolts	63 N·m (46 Ft. Lbs.)	—
5	FAD Bracket to FAD Nuts	30 N·m (22 Ft. Lbs.)	—
6	FAD Bracket to LH Engine Mount Bracket Bolt	35 N·m (26 Ft. Lbs.)	—

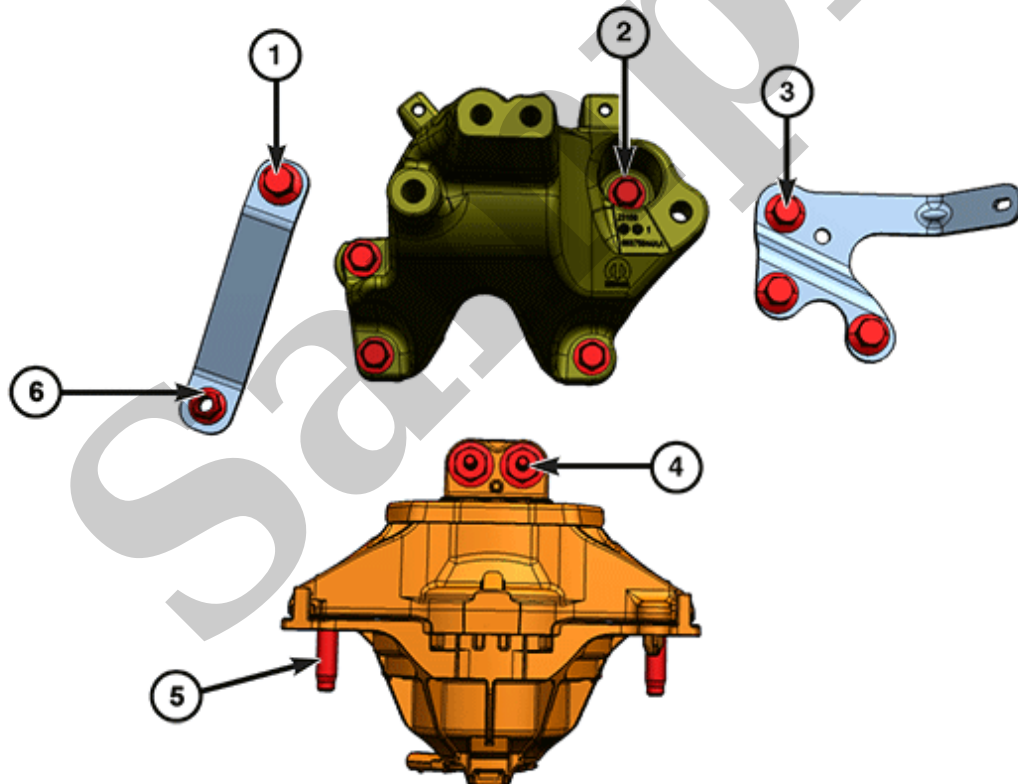

0912190384

## RIGHT ENGINE MOUNT

CALLOUT	DESCRIPTION	SPECIFICATION	COMMENTS
1	Front Diff Bracket to Engine mount Bracket	55 N·m (41 Ft. Lbs.)	—

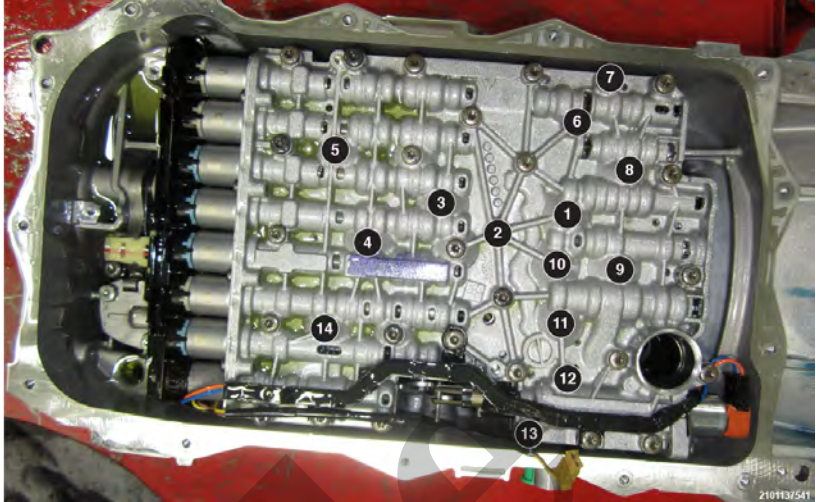
DESCRIPTION	SPECIFICATION	COMMENT
		

### TORQUE SPECIFICATIONS - AIR INTAKE

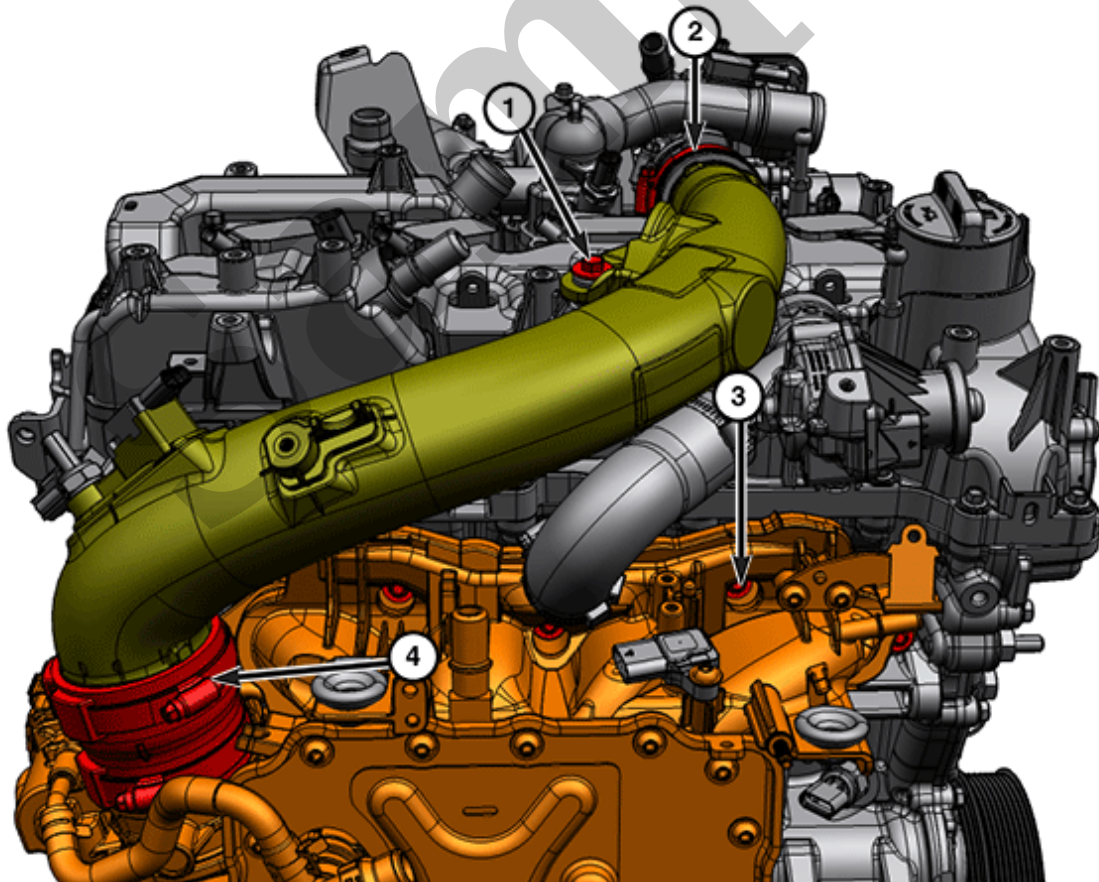

0903190370

CALLOUT	DESCRIPTION	SPECIFICATION	COMMENTS

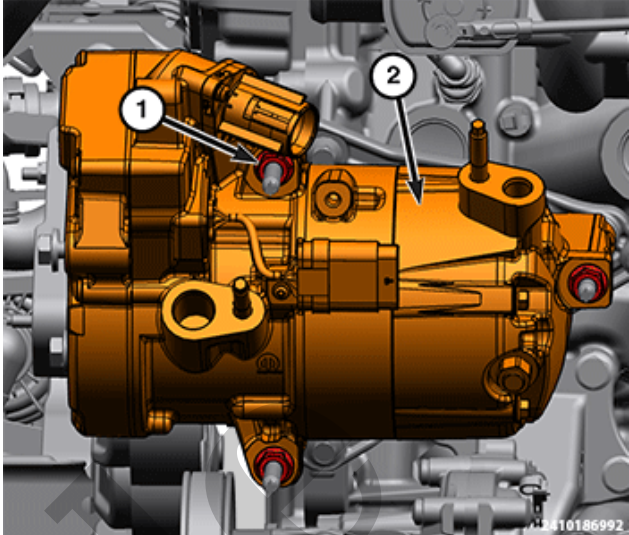
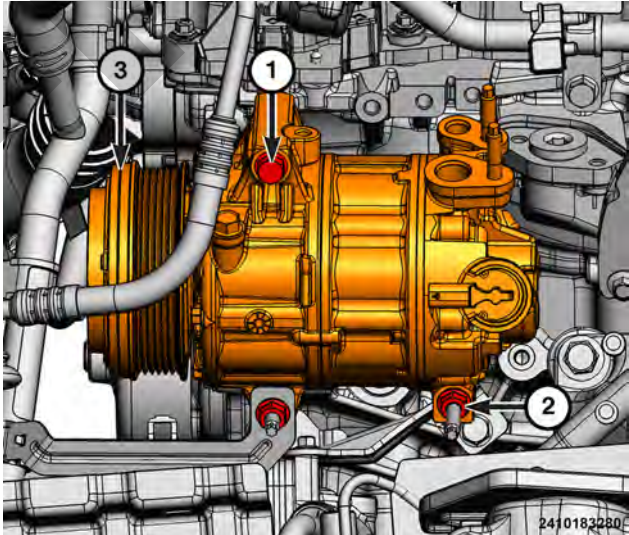

DESCRIPTION	SPECIFICATION	COMMENT
	<p>4. Tighten lower nut to 28 N·m (21 ft. Lbs.)</p>	
<p>A/C Compressor to Engine Bolt and Nuts - 3.6L Engine</p>	<p><b>Torque Procedure</b></p> <ol style="list-style-type: none"> <li>1. Install the nuts and hand tighten</li> <li>2. Install bolt and hand tighten.</li> <li>3. Tighten rearward nut to 28 N·m (21 ft. Lbs.)</li> <li>4. Tighten upper bolt to 28 N·m (21 ft. Lbs.)</li> <li>5. Tighten forward nut to 28 N·m (21 ft. Lbs.)</li> </ol>	<p>Tightening Sequence</p> 
<p>A/C Compressor to Engine Bolt and Nuts - 5.7L Engine</p>	<p><b>Torque Procedure</b></p> <ol style="list-style-type: none"> <li>1. Install the nuts and hand tighten</li> <li>2. Install bolt and hand tighten.</li> <li>3. Tighten upper nut to 28 N·m (21 ft.</li> </ol>	<p>Tightening Sequence</p>



1 - Torsional Damper Bolts

2. Remove and **DISCARD** the torsional damper bolts and remove the torsional damper.
3. Using a suitable tool clean all sealant from the bolt holes.

**INSTALLATION**

Follow the removal procedure in reverse for general reassembly of the components on the vehicle. The steps listed below are calling out specific procedures that should be followed during installation.

- Install the torsional damper and tighten the **NEW** torsional damper bolts finger tight.
- Using the tightening sequence shown, tighten the **NEW** torsional damper bolts to the proper torque specification.

**TORQUE SPECIFICATIONS - TRANSMISSION - 8P75PH**

DESCRIPTION	SPECIFICATION	COMMENT
Blocker to Transmission Bolts	<b>48 N·m (35 Ft. Lbs.)</b>	—
Coolant Hose Bracket to Transmission Nut	<b>8 N·m (71 In. Lbs.)</b>	—
Engine Block to Bellhousing Bolt	<b>48 N·m (35 Ft. Lbs.)</b>	—
Engine Oil Pan to Bellhousing Bolt	<b>50 N·m (37 Ft. Lbs.)</b>	—
High Voltage Cable Bracket to Transmission Bolts	<b>8 N·m (71 In. Lbs.)</b>	—
Integrated Electric Oil Pump (IEP) Bolts	<b>8 N·m (71 In. Lbs.)</b>	—
Manual Park Release Cable Bracket to Transmission Bolts	<b>20 N·m (15 Ft. Lbs.)</b>	—
MGU Harness Trough	<b>5 N·m (44 In. Lbs.)</b>	—

YOUR CURRENT VEHICLE

## Description And Operation - Piston Assembly

### DESCRIPTION AND OPERATION - PISTON ASSEMBLY

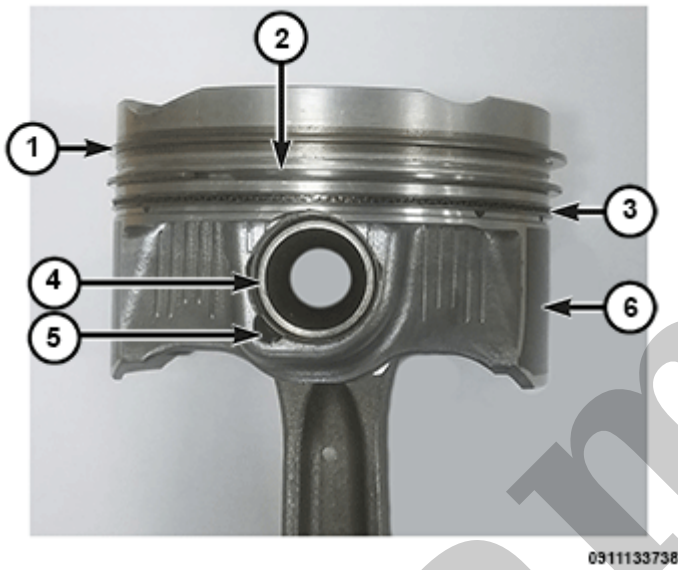

1 - Upper Compression Ring	4 - Full Floating Wrist Pin
2 - Intermediate Compression Ring	5 - Wrist Pin Locking Clip
3 - Three Piece Oil Control Ring	6 - Piston Skirt

### CAUTION

Do not use a metal stamp to mark connecting rods as damage may result, instead use ink or a scratch awl.

The pistons are a lightweight design with ultra low tension piston rings for improved fuel economy:

- The pistons are made of a high strength aluminum alloy and the piston skirt has a MolyT® coating.
- The top piston ring land has an anodized coating for improved wear performance.