

# Your Ultimate Source for OEM Repair Manuals

FactoryManuals.net is a great resource for anyone who wants to save money on repairs by doing their own work. The manuals provide detailed instructions and diagrams that make it easy to understand how to fix a vehicle.

## 2007 FORD C-Max OEM Service and Repair Workshop Manual

[Go to manual page](#)

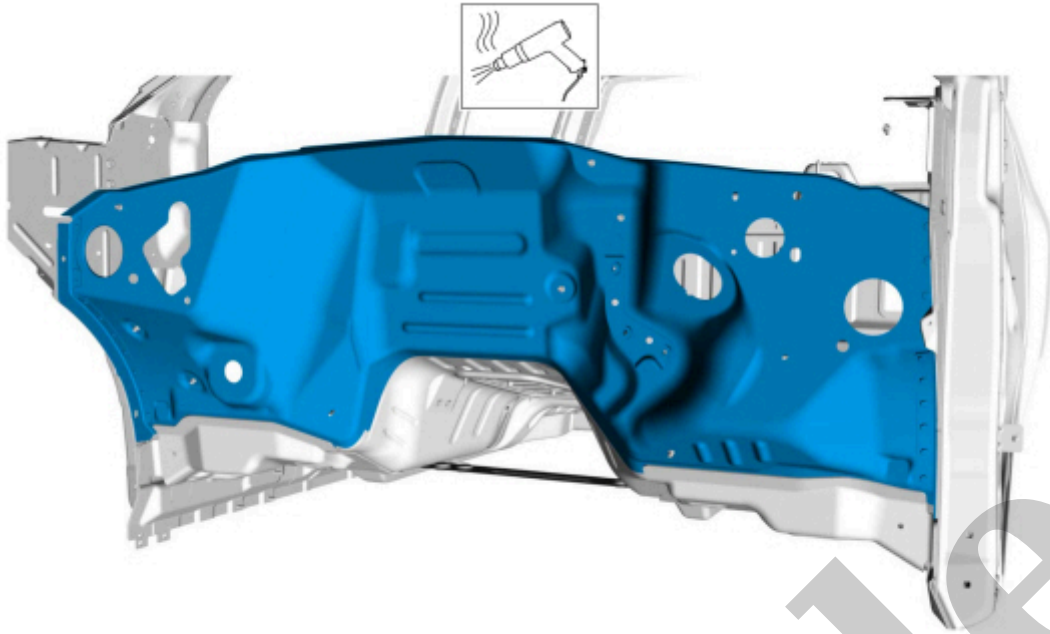

E339411

[Click here to learn about symbols, color coding, and icons used in this manual.](#)

### Installation

1. 80-120 grit sand paper.

Sand to remove e-coating and clean the service panel mating flange.

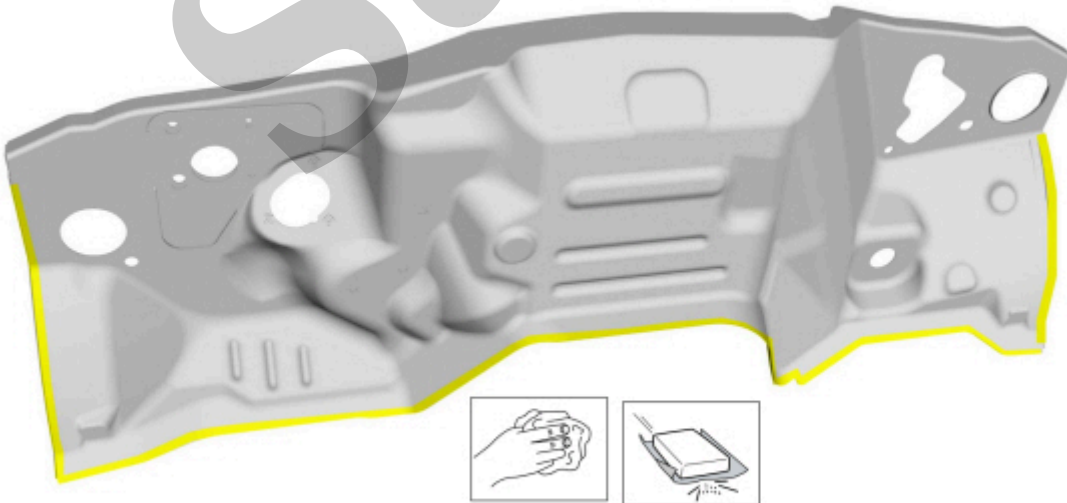

E339412

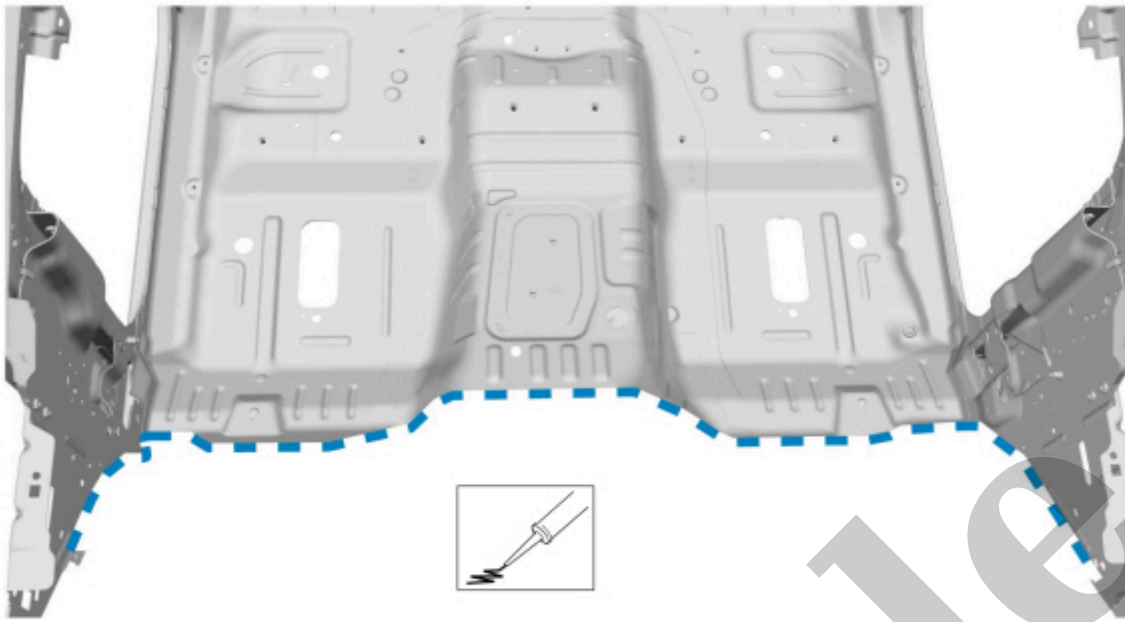

E339414

[Click here to learn about symbols, color coding, and icons used in this manual.](#)

4. Install the dash panel and clamp in position.

Use the General Equipment: Locking Pliers

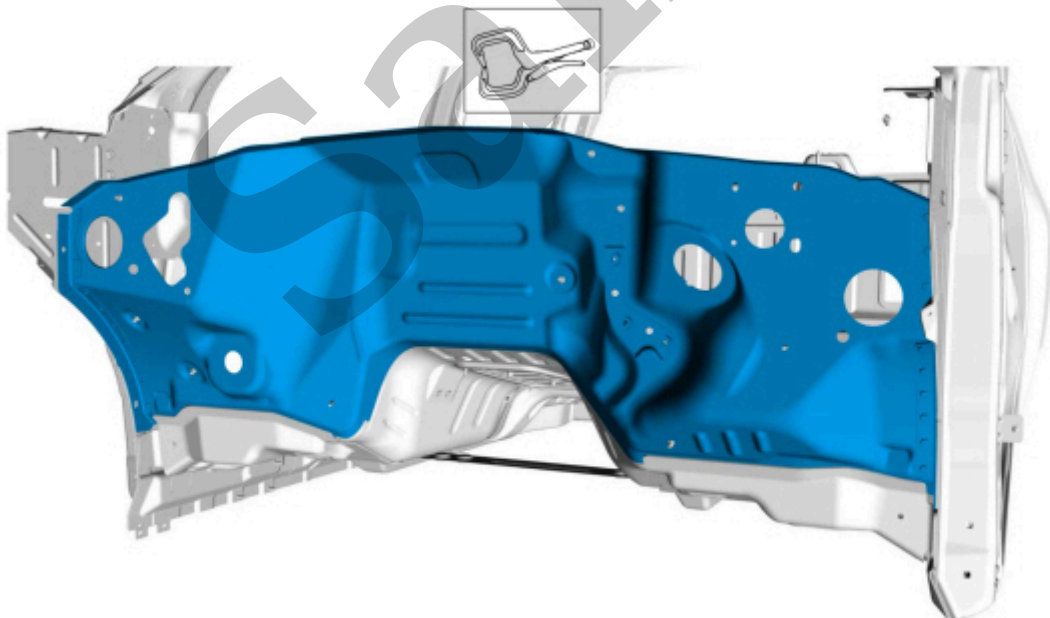

E339415

[Click here to learn about symbols, color coding, and icons used in this manual.](#)

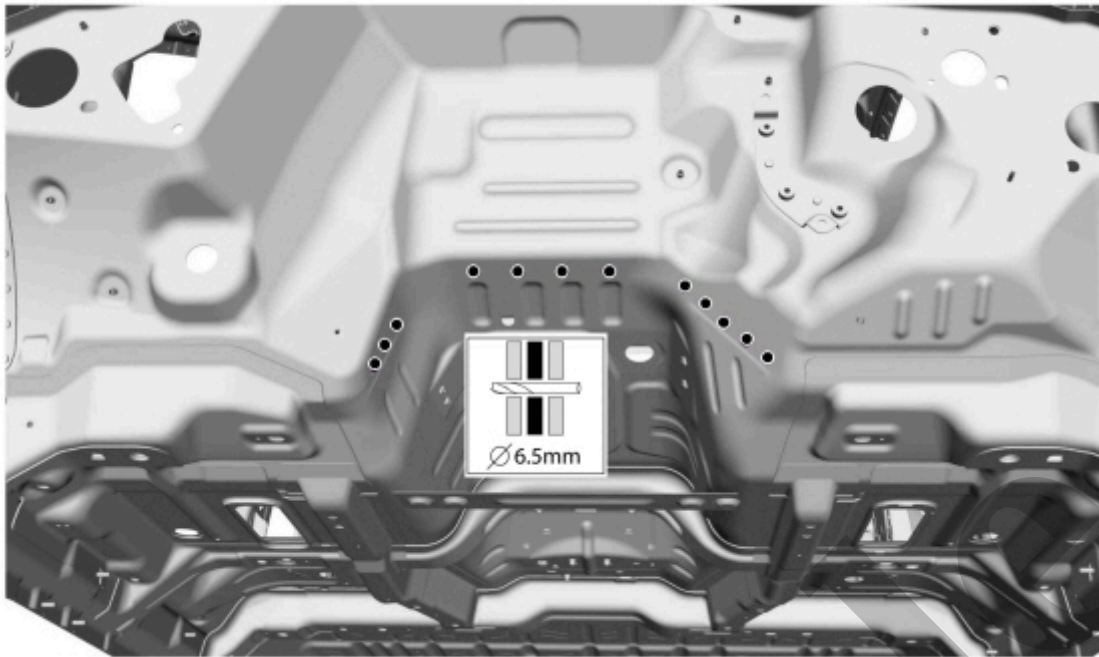

E339417

[Click here to learn about symbols, color coding, and icons used in this manual.](#)

**7. NOTE**

Blind rivets, solid rivet fasteners or aluminum MIG (metal inert gas) plug welds may be used in place of SPR (self-piercing rivet) fasteners after enlarging holes to 6.5 mm.

Install fasteners.

Item	SPR (self-piercing rivet) Number	SPR (self-piercing rivet) Code	Henrob®, Car-OLiner®, CMO®, Chief®, Spanesi®, Wielander and Schill® Mandrel	Pro-Spot® Mandrel	Blind Rivet	Solid Rivet	Rivnut®
1	-	-	-	-	W707638-S900C	-	-

Use the General Equipment: Blind Rivet Gun

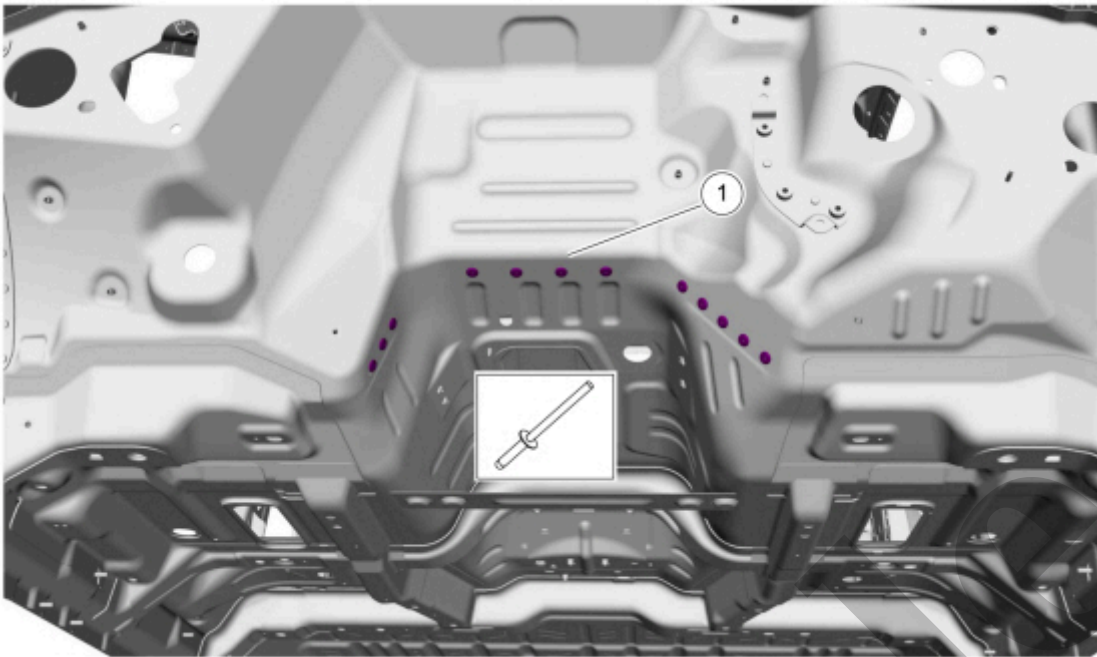

E339419

[Click here to learn about symbols, color coding, and icons used in this manual.](#)

9. Metal Finishing:

Metal finish as necessary using typical techniques and materials.

Refer to: [Special Repair Considerations for Aluminum Repairs](#)(501-25 Body Repairs - General Information, Description and Operation).

10. Seam Sealing:

All seams must be sealed to production level.

**Material** : Seam Sealer / TA-2-B, 3M™ 08308, LORD Fusor® 803DTM

11. Refinish the entire repair using a Ford approved paint system and typical refinishing techniques.

12. Install the cowl panel.

Refer to: [Cowl Panel](#)(501-27 Front End Sheet Metal Repairs, Removal and Installation).

13. Install the floor console.

Refer to: [Floor Console](#)(501-12 Instrument Panel and Console, Removal and Installation).

14. Repower the SRS (supplemental restraint system) .

Refer to: [Supplemental Restraint System \(SRS\) Repowering](#)(501-20B Supplemental Restraint System, General Procedures).



## Fender Apron Panel Reinforcement

<b>501-27 Front End Sheet Metal Repairs</b>	<b>2022 F-150</b>
<b>Removal and Installation</b>	<b>Procedure revision date: 02/23/2022</b>

### Fender Apron Panel Reinforcement

#### Removal

#### WARNING

Electric vehicles damaged by a crash may have compromised high voltage safety systems and present a potential high voltage electrical shock hazard. Exercise caution and wear appropriate Personal Protective Equipment (PPE) safety gear, including high voltage safety gloves and boots. Remove all metallic jewelry, including watches and rings. Isolate the HV system as directed by the Ford Emergency Response Guide for the vehicle. Failure to follow these instructions may result in serious personal injury or death.

#### NOTICE

Battery electric vehicle (BEV), hybrid electric vehicle (HEV) and plug-in hybrid electric vehicle (PHEV) contain a high-voltage battery. Before cutting or welding near the high-voltage battery it must be removed to avoid damage.

#### NOTE

Aluminum body panels are highly receptive to heat transfer. With the extensive use of structural adhesives and non-structural sealers used in vehicle construction, the potential of heat transfer could impact adhesives and sealers in non-associated panels during the repair process. Many repairs areas that utilize structural adhesive may be separated after fastener removal by using a panel chisel along the joint/flange.

Refer to: [Air Cleaner](#)(303-12E Intake Air Distribution and Filtering - 5.0L 32V Ti-VCT, Removal and Installation).

Refer to: [Air Cleaner](#)(303-12A Intake Air Distribution and Filtering - 2.7L EcoBoost (238kW/324PS), Removal and Installation).

### **All vehicles**

5. Remove the front bumper.

Refer to: [Front Bumper](#)(501-19 Bumpers, Disassembly and Assembly).

6. Remove the hood and hood hinge on the repair side.

Refer to: [Hood](#)(501-02 Front End Body Panels, Removal and Installation).

Refer to: [Hood](#)(501-02 Front End Body Panels, Removal and Installation).

### **Diesel/Flex Fuel – Ethanol/Full Hybrid Electric Vehicle (FHEV)/Gasoline**

7. LH (left-hand) side:

Remove the battery.

Refer to: [Battery](#)(414-01 Battery, Mounting and Cables, Removal and Installation).

### **All vehicles**

8. Remove the fender and fender splash shield.

Refer to: [Fender](#)(501-02 Front End Body Panels, Removal and Installation).

Refer to: [Fender](#)(501-02 Front End Body Panels, Removal and Installation).

Refer to: [Fender Splash Shield](#)(501-02 Front End Body Panels, Removal and Installation).

9. Remove the front door.

Refer to: [Front Door - Regular Cab/SuperCrew](#)(501-03 Body Closures, Removal and Installation).

Refer to: [Front Door - SuperCab](#)(501-03 Body Closures, Removal and Installation).

10. If Required:

Dimensionally restore the vehicle to pre-damage condition.

Refer to: [Body and Frame](#)(501-26 Body Repairs - Vehicle Specific Information and Tolerance Checks, Description and Operation).

### **Electric**

11. Remove the front storage compartment panels.

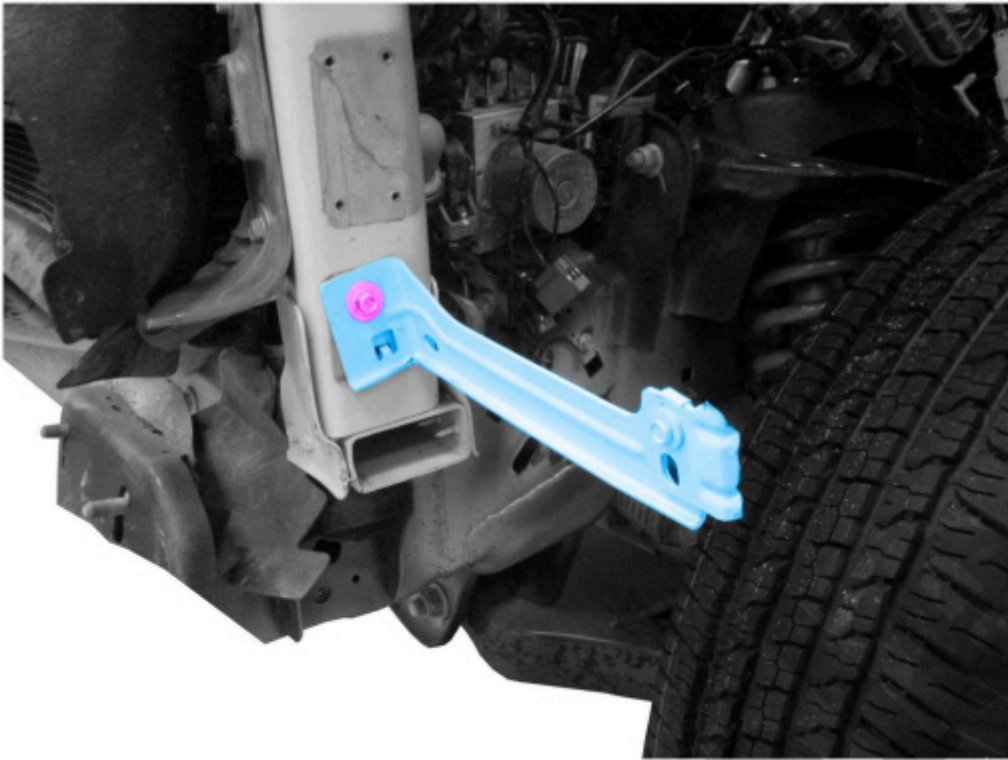

E192340

[Click here to learn about symbols, color coding, and icons used in this manual.](#)

#### **Diesel/Flex Fuel – Ethanol/Full Hybrid Electric Vehicle (FHEV)/Gasoline**

14. Remove the cooling module.

Refer to: [Cooling Module](#)(303-03A Engine Cooling - 2.7L EcoBoost (238kW/324PS), Removal and Installation).

Refer to: [Cooling Module](#)(303-03A Engine Cooling - 2.7L EcoBoost (238kW/324PS), Removal and Installation).

Refer to: [Cooling Module](#)(303-03B Engine Cooling - 3.3L Duratec-V6, Removal and Installation).

Refer to: [Cooling Module](#)(303-03C Engine Cooling - 3.5L EcoBoost (BM), Removal and Installation).

Refer to: [Cooling Module](#)(303-03D Engine Cooling - 3.5L V6 PowerBoost (CN), Removal and Installation).

#### **All vehicles**

15. Remove and discard the FDS (flow drill screw) fasteners.

Use the General Equipment: Polydrive Bit Socket



Use the General Equipment: Self-Piercing Rivet (SPR) Remover/Installer

Use the General Equipment: Belt Sander

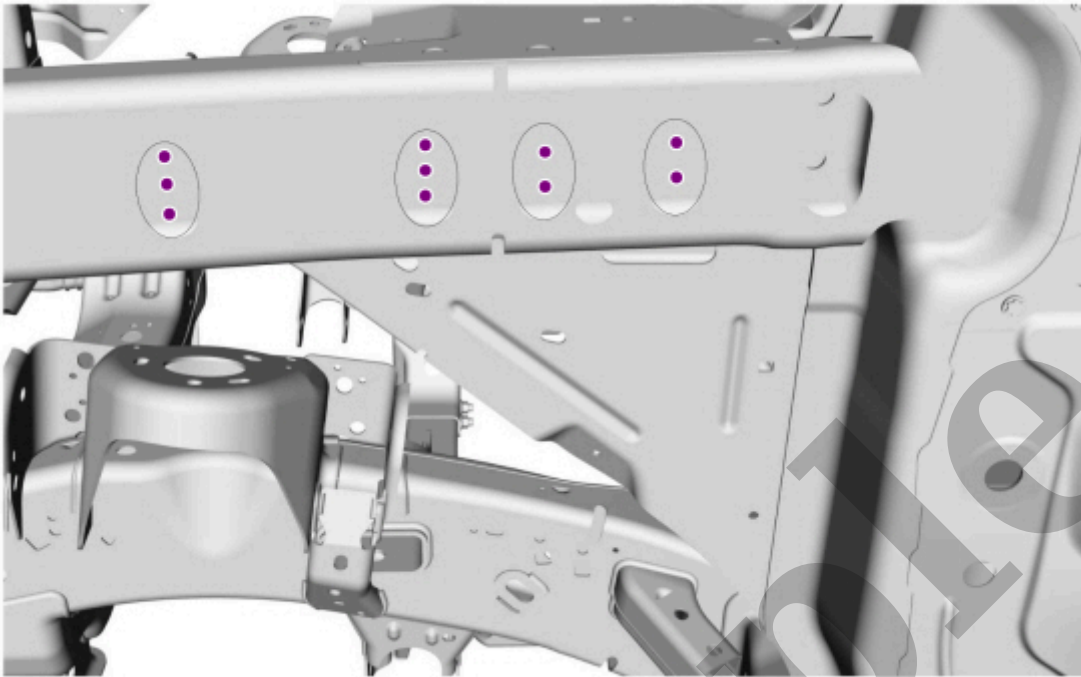

E330193

[Click here to learn about symbols, color coding, and icons used in this manual.](#)

18. Remove and discard the FDS (flow drill screw) and SPR (self-piercing rivet) fasteners.

Use the General Equipment: Polydrive Bit Socket

Use the General Equipment: Self-Piercing Rivet (SPR) Remover/Installer

Use the General Equipment: Belt Sander

## 20. NOTE

Aluminum body panels are highly receptive to heat transfer. With the extensive use of structural adhesives and non-structural sealers used in vehicle construction, the potential of heat transfer could impact adhesives and sealers in non-associated panels during the repair process. Many repairs areas that utilize structural adhesive may be separated after fastener removal by using a panel chisel along the joint/flange. Using heat not exceeding 425° F to loosen a bonded panel should only be done when **all panels in the joint** will be replaced and new adhesive applied.

Remove the fender apron panel reinforcement.

Use the General Equipment: Hot Air Gun

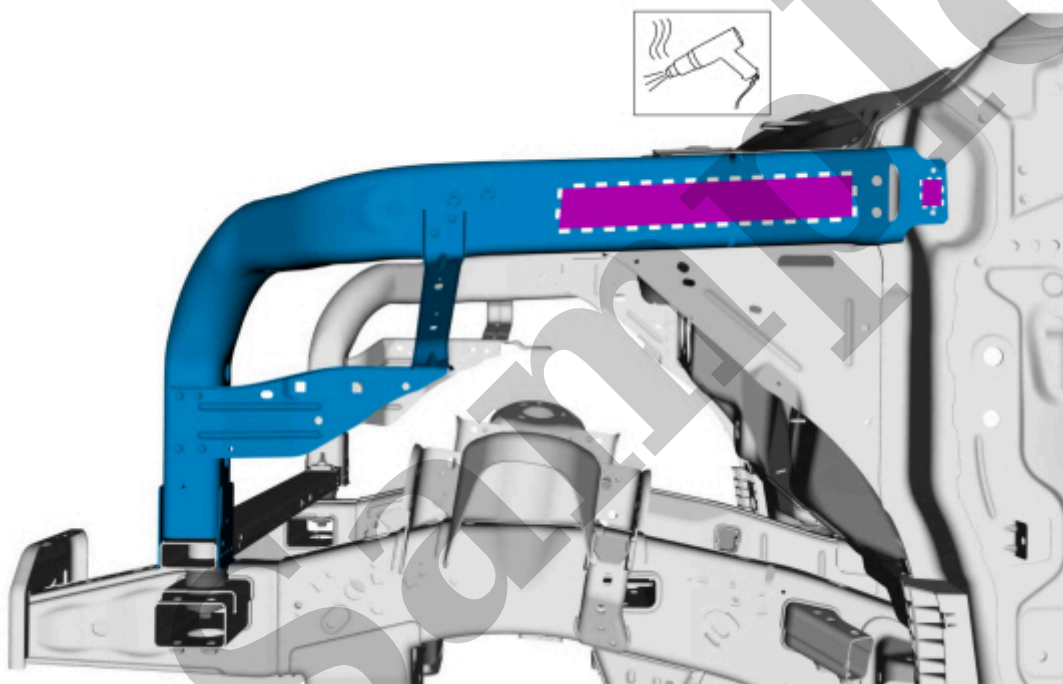

E330194

[Click here to learn about symbols, color coding, and icons used in this manual.](#)

## Installation

### WARNING

Electric vehicles damaged by a crash may have compromised high voltage safety systems and present a potential high voltage electrical shock hazard. Exercise caution and wear appropriate Personal Protective Equipment (PPE) safety gear, including high voltage safety gloves and boots. Remove all metallic jewelry,