

Your Ultimate Source for OEM Repair Manuals

FactoryManuals.net is a great resource for anyone who wants to save money on repairs by doing their own work. The manuals provide detailed instructions and diagrams that make it easy to understand how to fix a vehicle.

2005 TOYOTA Tacoma OEM Service and Repair Workshop Manual

[Go to manual page](#)

When replacing and removing components which rely on the corrosion protection effect of the coolant, it is essential to change the coolant. The cooling system must therefore be emptied and refilled.

In the case of other removal work involving the draining of part quantities of coolant, the coolant level must be topped up with new coolant.

- Mixing different coolants is not permitted.

Non-compliance will result in danger of component damage and/or engine damage.

- Filling specification absolutely must be adhered to.

The operation of the vehicle is not permitted unless the filling procedure has been completed. Otherwise, functional limitations (degradation) and/or overheating may occur.

A bleeding procedure is required after a part has been exchanged in the cooling system and/or after refilling the cooling system.

HINT:

- Before starting the automatic cooling system bleeding routine, make sure that all coolant circuits are filled. If the cooling system bleeding routine is started while one of the coolant circuits is empty, there is a risk of damage to the electric coolant pump when running it dry.
- Make sure that negative (-) battery terminal is not disconnected for the bleeding procedure. Switch on low-beam headlights and hazard warning lights. If the low-beam headlights and hazard warning lights are not switched on, the engine switch off automatically after a certain period of time and interrupt the bleeding procedure.

- (a) Add engine coolant to the level shown in the illustration.

Standard Capacity:

10.5 liters (11.1 US qts, 9.2 Imp. qts)

- (1) Expendable materials : Antifreeze and Corrosion Inhibitor
Frostox HT-12

HINT:

When using Antifreeze and Corrosion Inhibitor Frostox HT-12, dilute the Antifreeze and Corrosion Inhibitor Frostox HT-12 to 50% before using it.

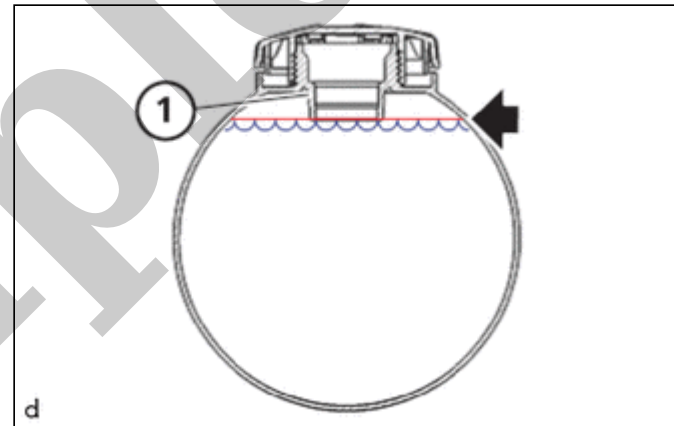

- (b) Open the bleeder screw on the radiator reserve tank assembly for the high-temperature coolant circuit and close it again after approx. 10 s.

- (1) You can close the bleeder screw prior to expiry of the 10 s once coolant escapes.

- (c) Close the reserve tank cap sub-assembly on the radiator reserve tank assembly of the high-temperature cooling circuit.

- (d) Make sure the bonnet is closed.[*1]

- (e) Make sure that the wheels touch the ground.[*2]

- (f) Engage the parking brake.[*3]

- (g) Engage into both "P" or "N" automatic transmissions.[*4]

- (h) Press the START-STOP button (engine switch) 3 times within 0.8 seconds to enter Diagnostic (PAD) Mode.[*5]

- (i) Turn on low-beam headlight and the hazard warning light.[*6]

HINT:

If the low-beam headlights and hazard warning lights are not switched on, the engine switch off automatically after a certain period of time and interrupt the bleeding procedure.

- (j) Adjust the heating to maximum temperature and adjust the blower to the lowest stage.[*7]

- (k) Hold the accelerator pedal down for at least 10 s at limit position and do not step onto the brake pedal.[*8]

- (l) Start engine.[*9]

- (m) The cooling system bleeding routine has been started, pay attention to the display on the instrument cluster (KOMBI). ("Service function started")[*10]

Last Modified: 07-26-2024

6.11:8.1.0

Doc ID: RM100000001R4ZM

Model Year Start: 2021

Model: Supra

Prod Date Range: [07/2020 -]

Title: MAINTENANCE: B46 DRIVE BELT: COMPONENTS; 2021 - 2025 MY Supra [07/2020 -]

COMPONENTS

ILLUSTRATION

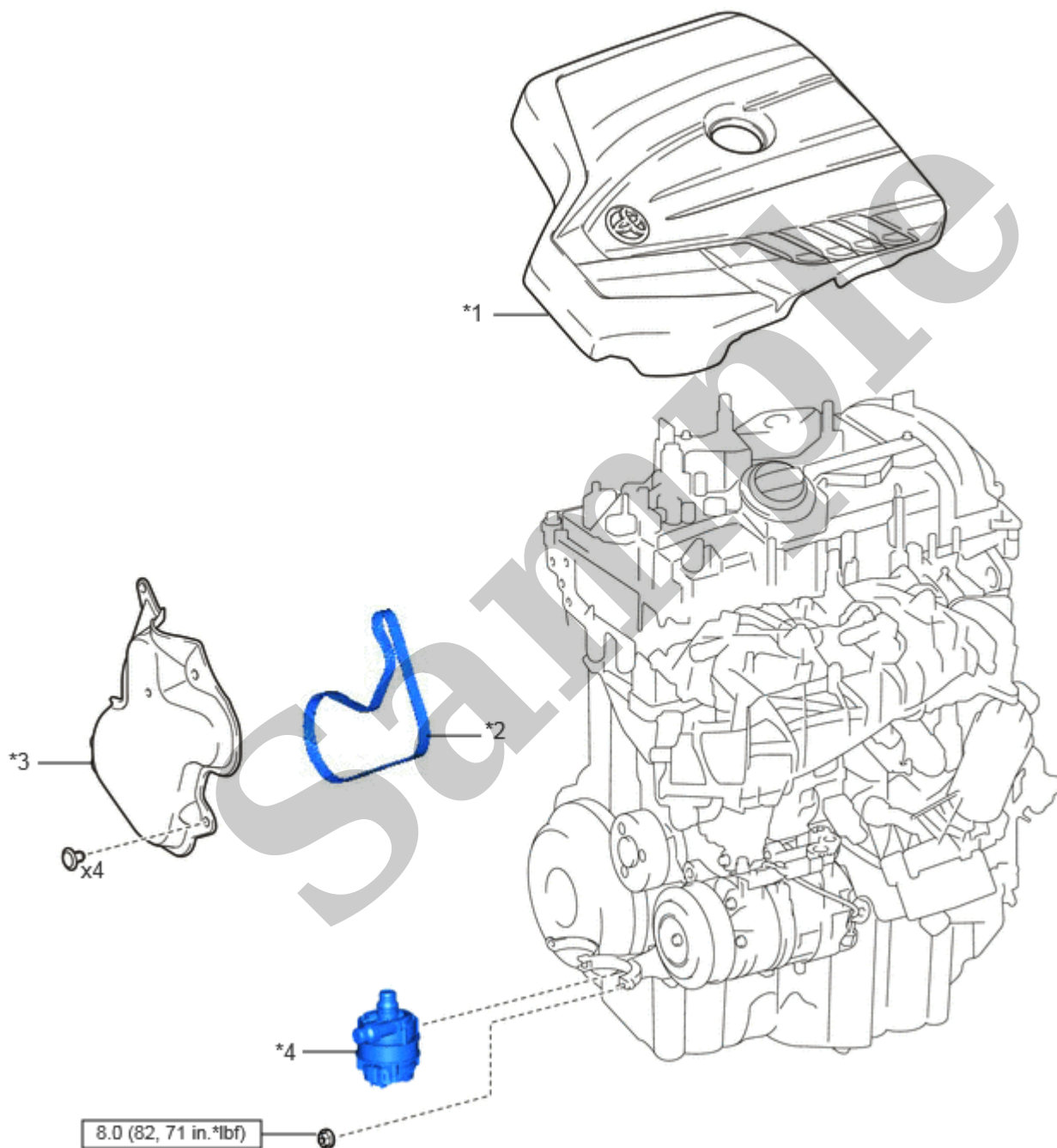

*1 NO. 1 ENGINE COVER SUB-ASSEMBLY

*2 FAN AND GENERATOR V BELT

*3 CYLINDER BLOCK COVER

*4 WATER PUMP SUB-ASSEMBLY

Last Modified: 07-26-2024

6.11:8.1.0

Doc ID: RM100000001R4ZN

Model Year Start: 2021

Model: Supra

Prod Date Range: [07/2020 -]

Title: MAINTENANCE: B46 DRIVE BELT: REMOVAL; 2021 - 2025 MY Supra [07/2020 -]

REMOVAL

PROCEDURE

1. REMOVE NO. 1 ENGINE COVER SUB-ASSEMBLY

Click here [INFO](#)

2. REMOVE NO. 2 AIR CLEANER HOSE

Click here [INFO](#)

3. REMOVE CYLINDER BLOCK COVER

(a) Loosen clamps (1).

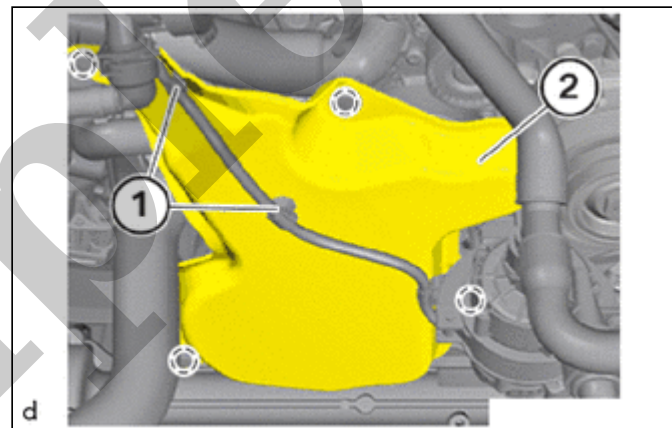

(b) Release all expanding rivets in marked areas.

(c) Guide out the cylinder block cover (2).

4. REMOVE WATER PUMP SUB-ASSEMBLY

(a) Unlock and loosen connector (1).

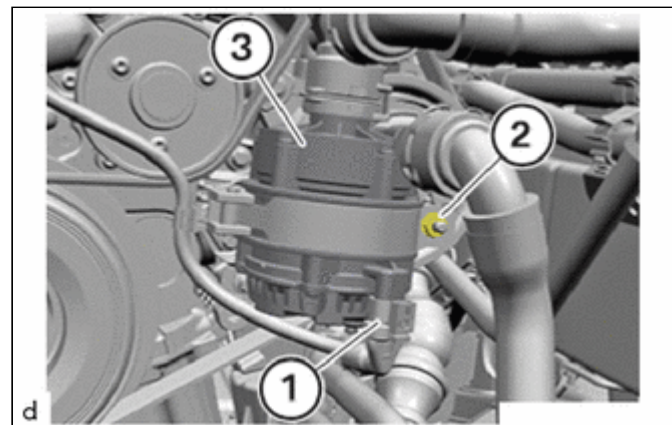

(b) Unscrew the nut (2) on the holder.

(c) Guide the water pump sub-assembly (3) out of the holder and set it aside.

5. REMOVE FAN AND GENERATOR V BELT

Last Modified: 07-26-2024	6.11:8.1.0	Doc ID: RM100000001R4ZO
Model Year Start: 2021	Model: Supra	Prod Date Range: [07/2020 -]
Title: MAINTENANCE: B46 DRIVE BELT: INSTALLATION; 2021 - 2025 MY Supra [07/2020 -]		

INSTALLATION

PROCEDURE

1. INSTALL FAN AND GENERATOR V BELT

CAUTION:

- Component with preload.

Danger of injury!

- Reduce preload as far as possible before disassembly. Relieve component.

(a) Feed in the fan and generator V belt (1) and install it.

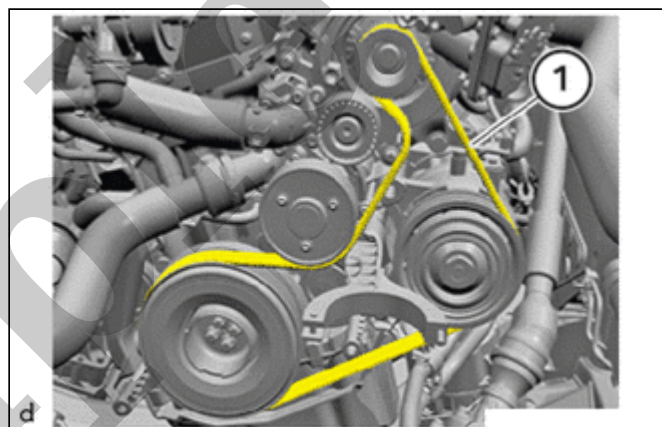

(b) Using 16 mm socket, raise the preloading on the belt tensioner (1) in the direction of arrow.

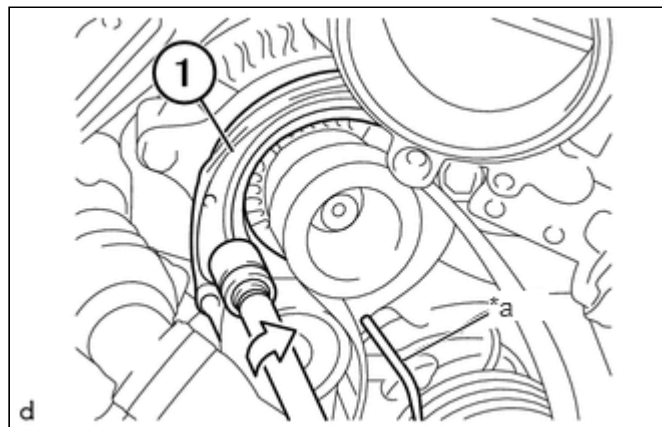

*a	4 mm Hexagon Wrench
----	---------------------

(c) Remove the 4 mm hexagon wrench from belt tensioner (1).

2. INSTALL WATER PUMP SUB-ASSEMBLY

(a) Feed in and install the water pump sub-assembly (3).