

Your Ultimate Source for OEM Repair Manuals

FactoryManuals.net is a great resource for anyone who wants to save money on repairs by doing their own work. The manuals provide detailed instructions and diagrams that make it easy to understand how to fix a vehicle.

2005 FORD Focus C-Max OEM Service and Repair Workshop Manual

[Go to manual page](#)



[Click here to learn about symbols, color coding, and icons used in this manual.](#)

Installation

1. To install, reverse the removal procedure.

Copyright © Ford Motor Company

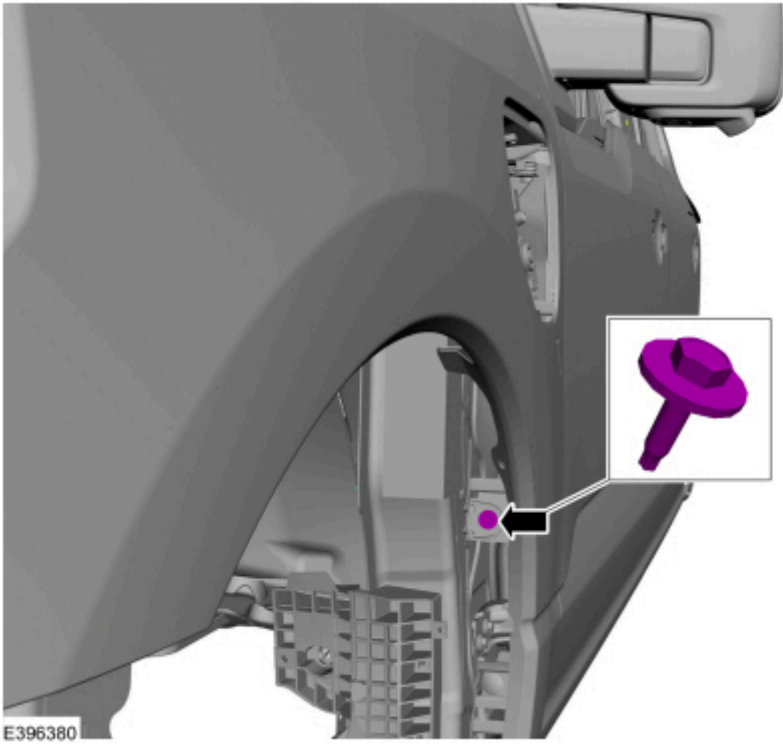

[Click here to learn about symbols, color coding, and icons used in this manual.](#)

3. Remove the bolts.

Torque : 80 lb.in (9 Nm)

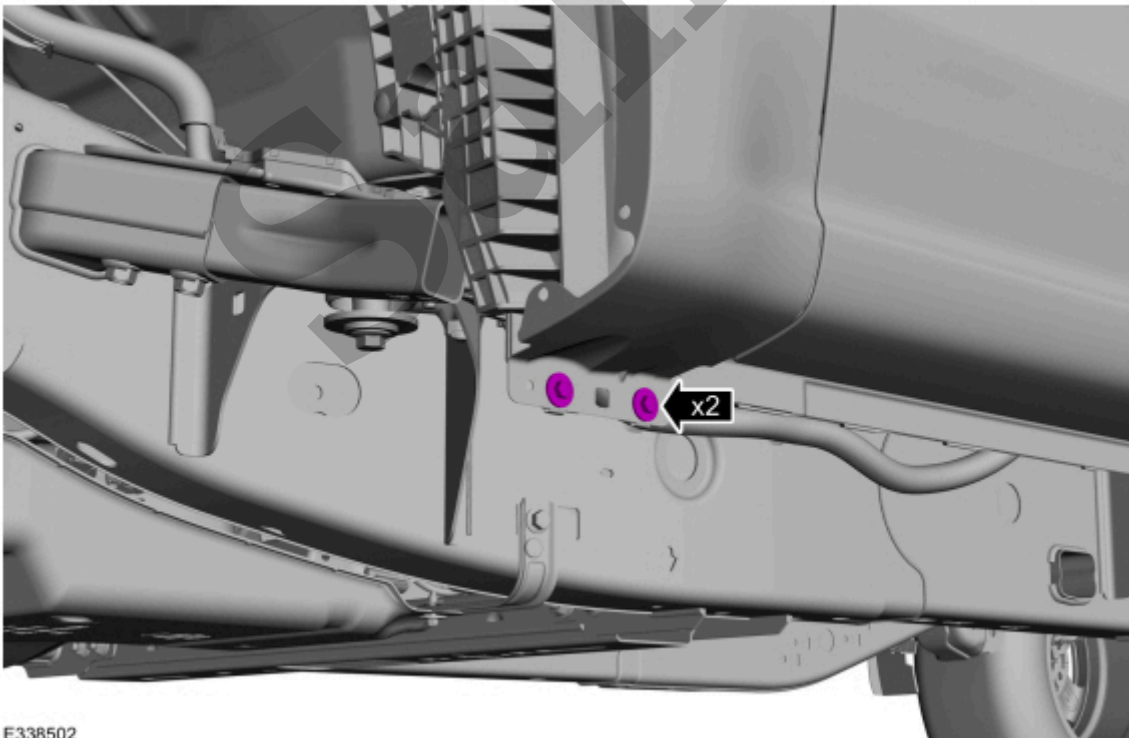

[Click here to learn about symbols, color coding, and icons used in this manual.](#)

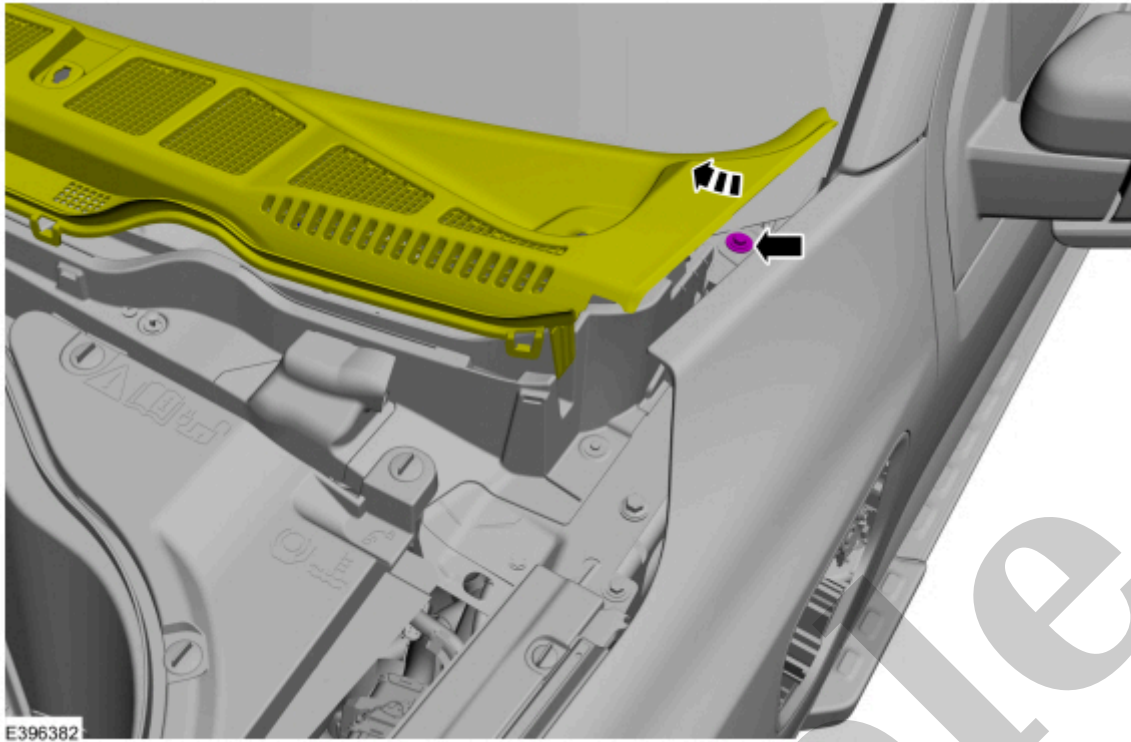

[Click here to learn about symbols, color coding, and icons used in this manual.](#)

6. Remove the headlamp assembly.

Refer to: [Headlamp Assembly](#)(417-01 Exterior Lighting, Removal and Installation).

7. Remove the bolt.

Torque : 80 lb.in (9 Nm)

9. On LH (left-hand) side.

Remove the charge port.

Refer to: [Charge Port - Electric](#)(414-03B High Voltage Battery Charging System, Removal and Installation).

10. Remove the bolts and the fender.

Torque : 80 lb.in (9 Nm)

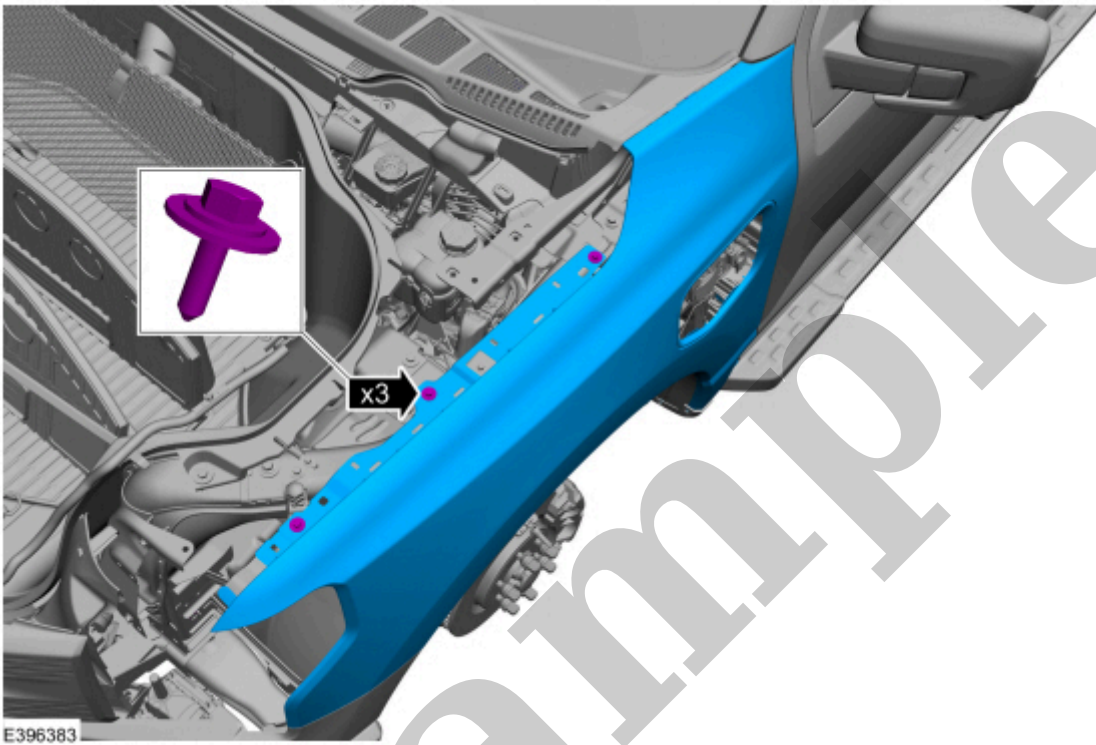

[Click here to learn about symbols, color coding, and icons used in this manual.](#)

11. **NOTE**

This step is only necessary when installing a new component.

Remove the push pins and the expandable foam baffle.

Fender Splash Shield

501-02 Front End Body Panels	2022 F-150
Removal and Installation	Procedure revision date: 10/2/2020

Fender Splash Shield

Removal

NOTE

LH (left-hand) side shown, RH (right-hand) side similar.

1. Remove the wheel and tire.

Refer to: [Wheel and Tire](#)(204-04A Wheels and Tires, Removal and Installation).

2. If equipped.

Remove the pin-type retainer, bolts and remove the front fender moulding.

Torque : 15 lb.in (1.7 Nm)

4. Remove the bolts.

Torque : 15 lb.in (1.7 Nm)



[Click here to learn about symbols, color coding, and icons used in this manual.](#)

5. Remove the pin-type retainers.

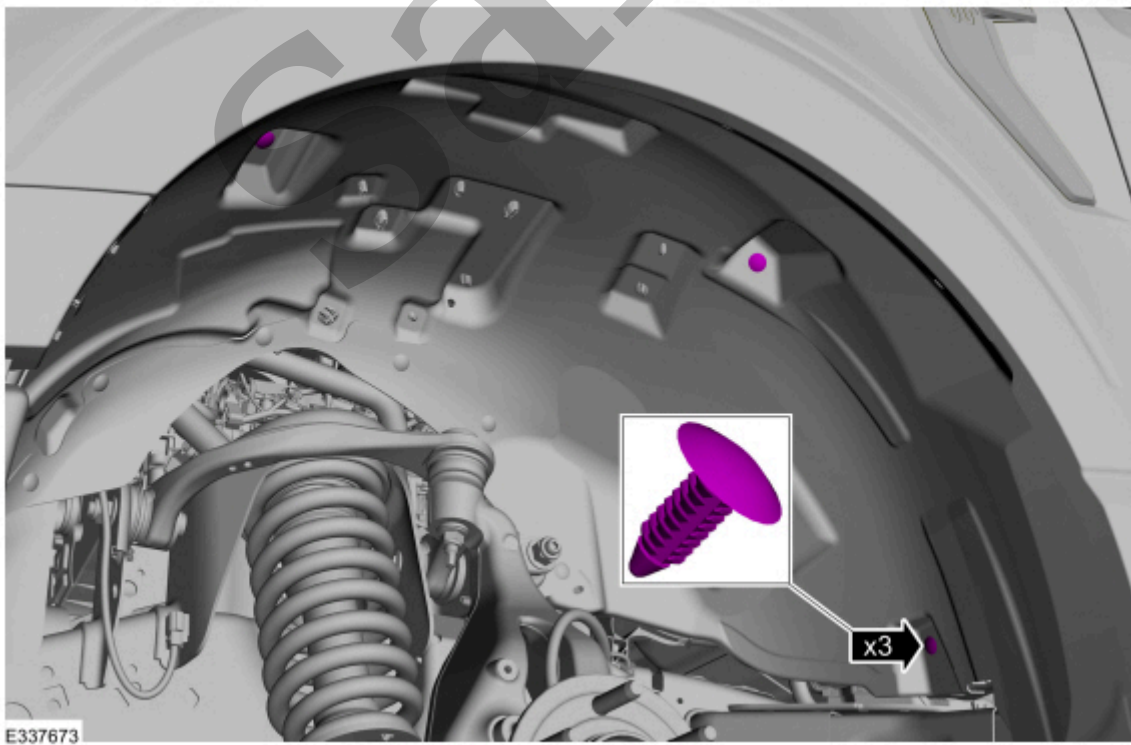



Fender

501-02 Front End Body Panels	2022 F-150
Removal and Installation	Procedure revision date: 10/2/2020

Fender

Removal

NOTE

Removal steps in this procedure may contain installation details.

NOTE

LH (left-hand) side shown, RH (right-hand) side similar.

1. Remove the fender splash shield.

Refer to: [Fender Splash Shield](#)(501-02 Front End Body Panels, Removal and Installation).

2. Remove the bolt.

Torque : 80 lb.in (9 Nm)

4. Remove the bolt.

Torque : 44 lb.in (5 Nm)

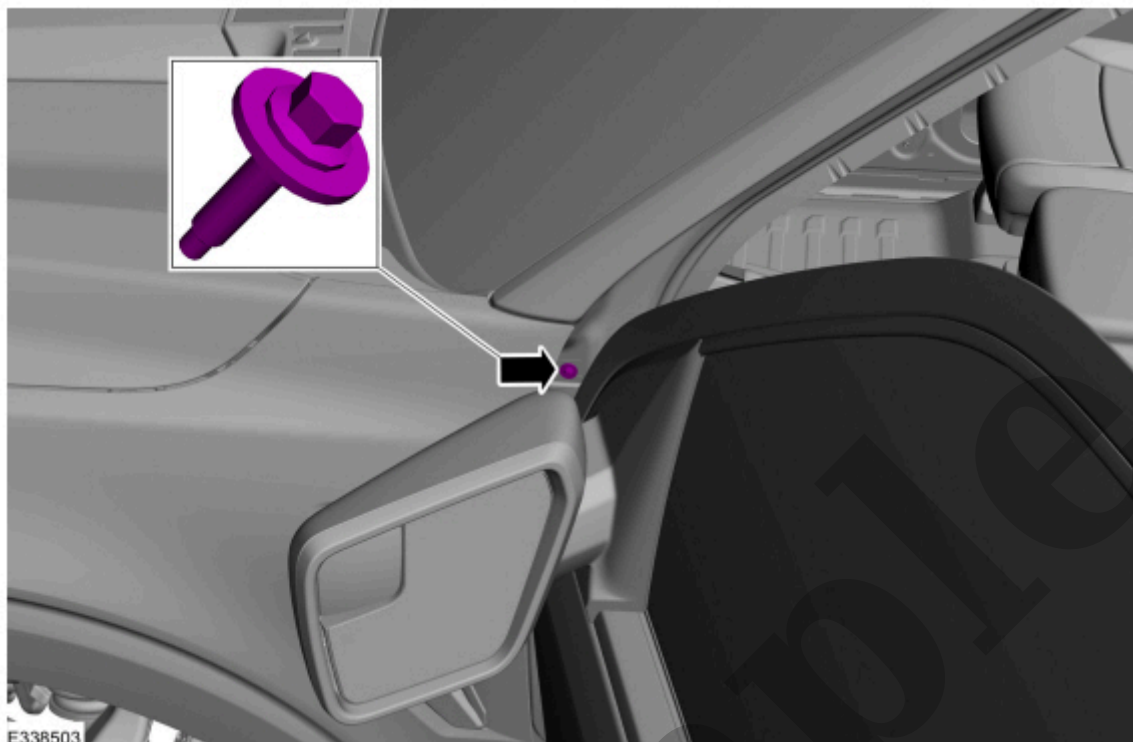

[Click here to learn about symbols, color coding, and icons used in this manual.](#)

5. Lift the corner of the cowl panel grille and remove the bolt.

Torque : 80 lb.in (9 Nm)

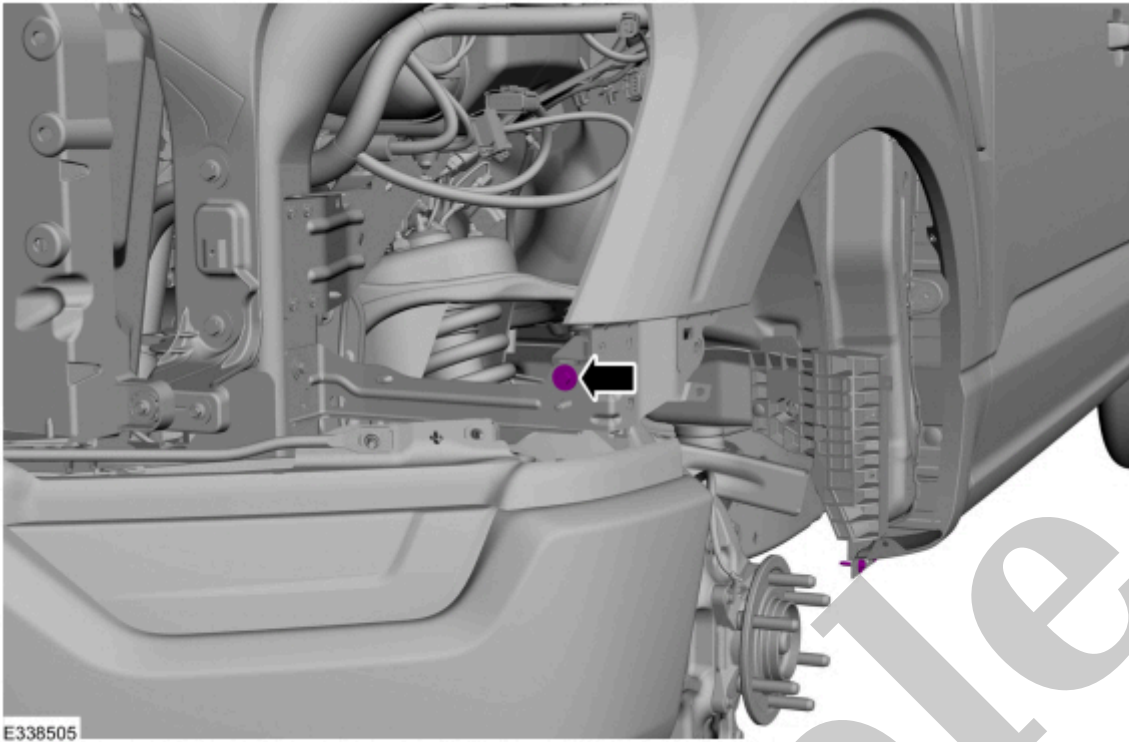

[Click here to learn about symbols, color coding, and icons used in this manual.](#)

8. Using a knife, cut the foam sealant between the fender and the body.

Use the General Equipment: Knife

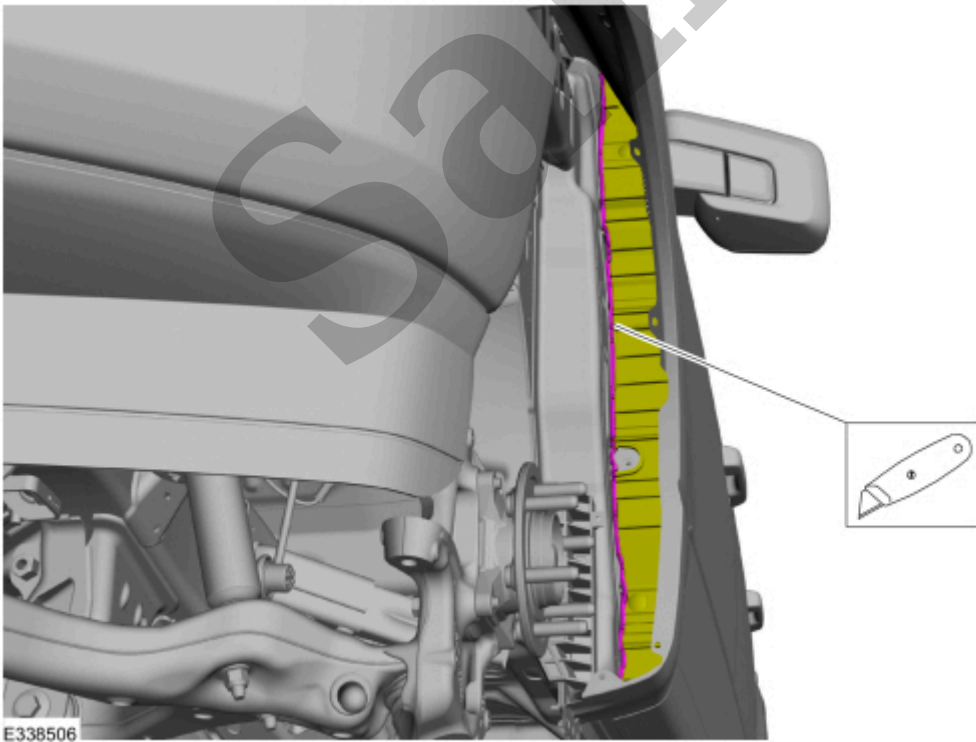

[Click here to learn about symbols, color coding, and icons used in this manual.](#)