

Your Ultimate Source for OEM Repair Manuals

FactoryManuals.net is a great resource for anyone who wants to save money on repairs by doing their own work. The manuals provide detailed instructions and diagrams that make it easy to understand how to fix a vehicle.

2004 FORD Thunderbird OEM Service and Repair Workshop Manual

[Go to manual page](#)

- Symptom charts, DTC (diagnostic trouble code) charts and diagnostic tests
- See the Diagnosis and Testing Information in this document
- General Procedures
 - Service adjustments, electronic programming and other special procedures
- Removal and Installation
 - Component removal and installation instructions
- Removal
 - Component removal instructions
- Installation
 - Component installation instructions
- Disassembly and Assembly
 - Component disassembly and assembly instructions
- Disassembly and Assembly of Subassemblies
 - Assembly disassembly and assembly instructions

IMPORTANT INFORMATION

Section number 100-00 General Information contains the following important information (including this document):

- Critical Health and Safety Precautions - service safety precautions applicable to the entire manual.

For additional information, refer to: [Health and Safety Precautions](#)(100-00 General Information, Description and Operation).

- A Symbols Glossary - definitions of the action directed by each symbol.

For additional information, refer to: [Symbols Glossary](#)(100-00 General Information, Description and Operation).

- Diagnostic Methods - support information for diagnostics.

For additional information, refer to: [Diagnostic Methods](#)(100-00 General Information, Description and Operation).

Warnings, Notices and Notes

WARNINGS

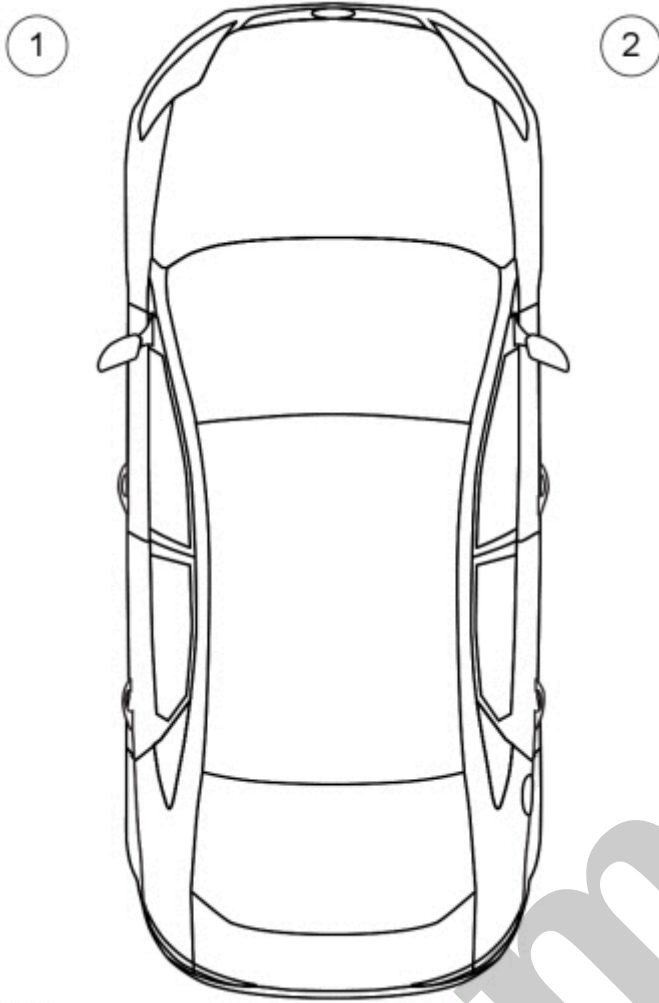

E126780

Item	Part Number	Description
1	—	LH (left-hand)
2	—	RH (right-hand)

All LH (left-hand) and RH (right-hand) engine designations are oriented from the flywheel position looking toward the crankshaft pulley.

Powertrain LH (left-hand) and RH (right-hand) definition

- Reuse standard fasteners.
- Replace fasteners with self-locking features.
 - Examples of fastener self-locking coatings or mechanical locking (with the locking features highlighted yellow) are shown in the illustration.

Examples of self-locking nuts and bolts

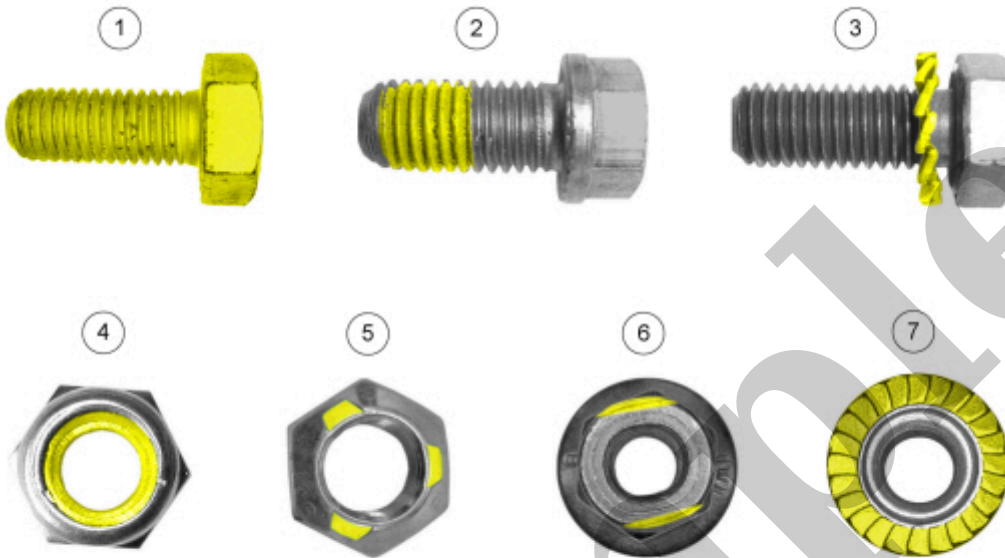

E126782

Item	Part Number	Description
1	—	Completely coated self-locking bolt
2	—	Partially coated self-locking bolt
3	—	Self-locking bolt with a locking washer
4	—	Self-locking nut with a plastic locking insert
5	—	Self-locking nut with thread deformation (3 indentations)
6	—	Self-locking nut with thread deformation (to oval shape)
7	—	Self-locking nut with integrated locking ring

Illustrations in this manual may be used instead of written step instructions. Color-coding (see color scheme illustration) is used to communicate the required step action or actions. Service action icons may be used to add information regarding the required action.

For additional information, refer to: [Symbols Glossary](#)

(100-00 General Information, Description and Operation).

Illustration Color-coding

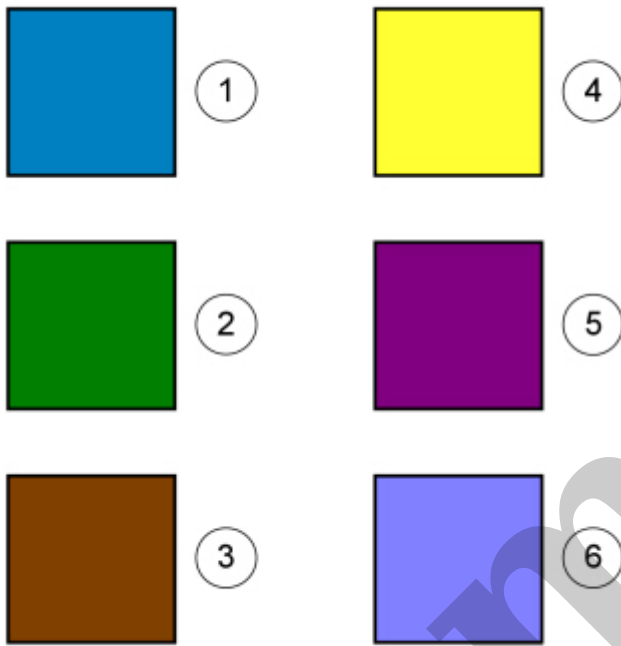

E141161

Item	Part Number	Description
1	—	Blue - Target or primary component to be removed/installed (or disassembled/assembled).
2	—	Green - Components that need to be removed prior to or installed after the target/primary.
3	—	Brown - Components that need to be removed prior to or installed after the target/primary.
4	—	Yellow - Components to be set aside for access, but not removed. Also highlighted areas to inspect or adjust.

Black arrows are used to draw attention to components (usually fasteners). Arrows with multiples specified (here, x2) identify an identical number of fasteners or items. Callouts (numbers inside circles) show a required sequence or tightening torque.

In the illustration, the callouts indicate the removal sequence, **which is reversed for installation**. The yellow coloring of the hose indicates it is to be positioned aside (not removed). Two identical (magenta-colored) fasteners are indicated by the x2 arrow. The fasteners in this illustration require different torques (same torque for the x2 fasteners) so numbered callouts are used to identify them with torque values in the associated step text. The (magenta-colored) hose clamp is another fastener to be removed.

Examples of fastener removal sequence and an identical service action for 12 fasteners. Other possible symbols are shown on the right.

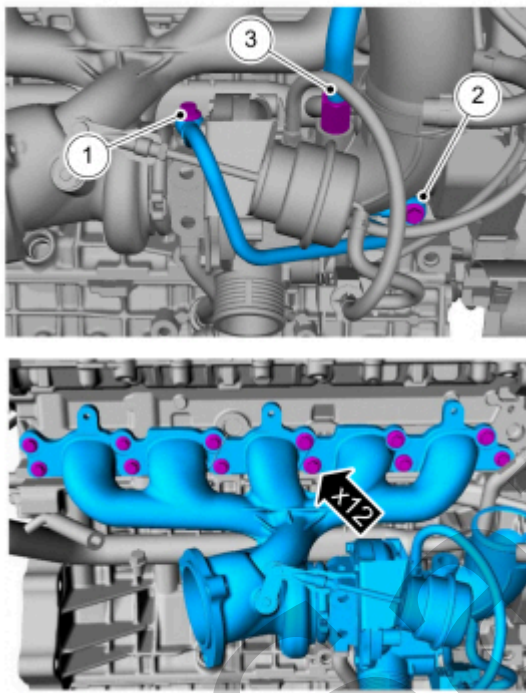

E84837

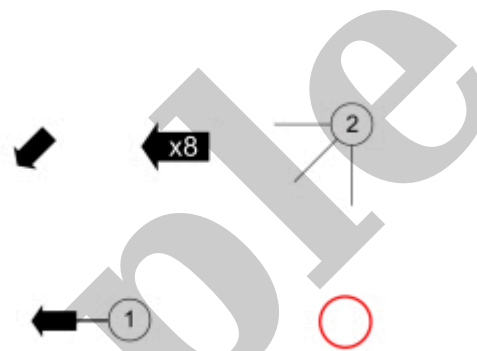

Example of fastener sequence information with two persons required for the service action

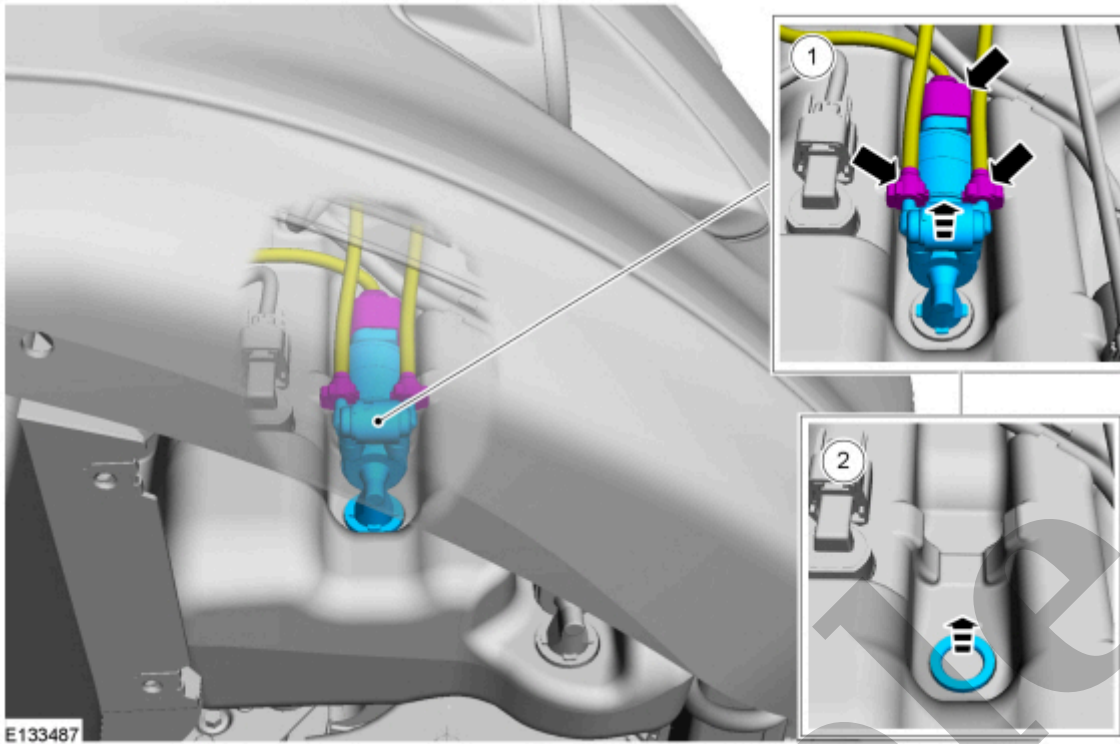

SERVICE ACTION ICONS

Service action icons may be used to add information regarding the required action.

For additional information, refer to: [Symbols Glossary](#)

(100-00 General Information, Description and Operation).

Location symbols show the location of a component or system on the vehicle.

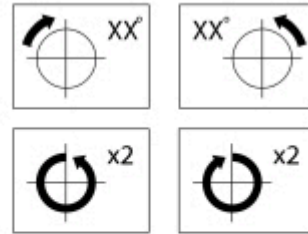
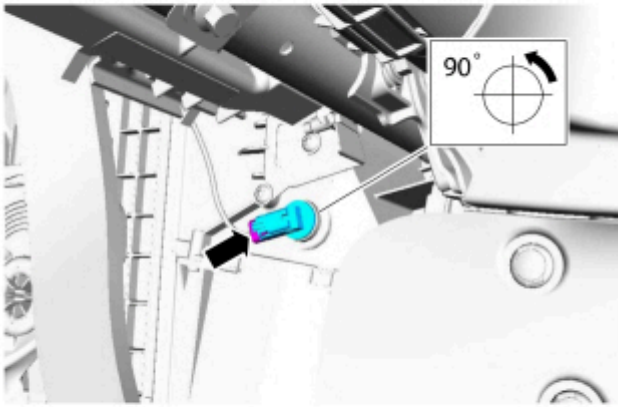

E84838

Instruction symbols are used to apply sealer, lubricant, weight, tape or cleaning detergent to a component.



E84834

Measurement symbols provide the information required to perform a specific measurement. These symbols may include specific values.

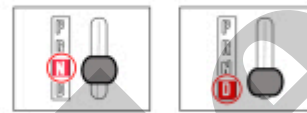
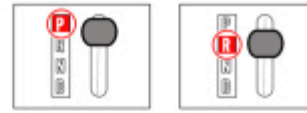
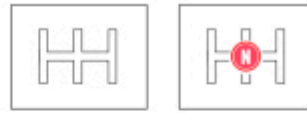
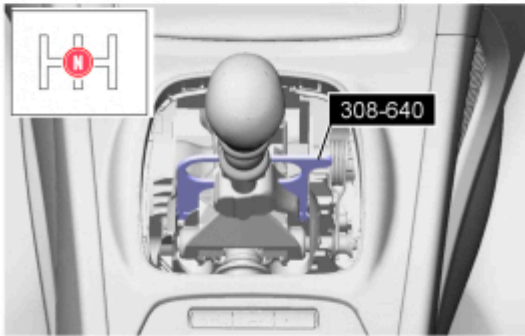

E84836

Example of two illustrations used together with sequence steps, service action icons and special service tools

Sample

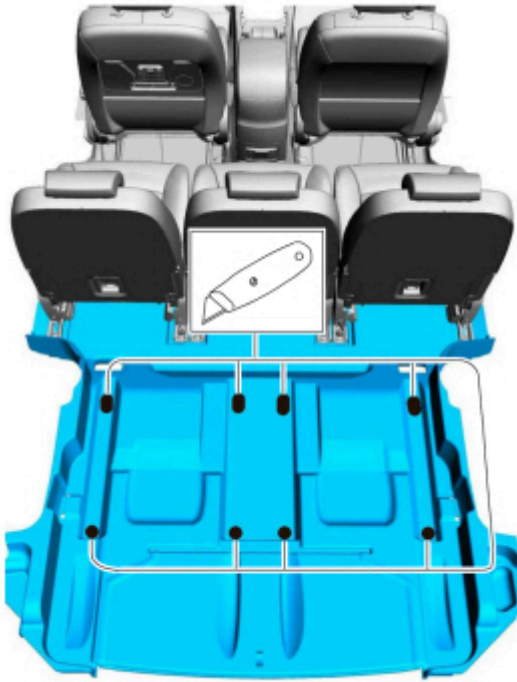

E84839



HEALTH AND SAFETY SYMBOLS

Some procedures may contain health and safety symbols that are associated with a specific service action.

For additional information, refer to: [Symbols Glossary](#)

(100-00 General Information, Description and Operation).

Always read and understand all health and safety precautions found in Section 100-00 before beginning any procedure. For additional information, refer to: [Health and Safety Precautions](#)

(100-00 General Information, Description and Operation).

ISO warning symbols may be used to indicate potential hazards.