

Your Ultimate Source for OEM Repair Manuals

FactoryManuals.net is a great resource for anyone who wants to save money on repairs by doing their own work. The manuals provide detailed instructions and diagrams that make it easy to understand how to fix a vehicle.

2003 NISSAN Sentra OEM Service and Repair Workshop Manual

[Go to manual page](#)

Precaution for Parking Brake System

RDE-001974888

- When the electric parking brake is operated, the electric parking brake warning lamp in the combination meter and the parking brake switch indicator turn ON.
- When a following malfunction occurs in the electric parking brake system, the electric parking brake warning lamp turn ON, electric parking brake warning lamp turn ON/OFF (depends on the electric parking brake system) or blink, and parking brake switch indicator ON/OFF (depends on the electric parking brake system) or blink.
 - When a status cannot be judged between applied and released.
 - When the parking brake switch is operated under the condition that the parking brake switch is malfunction.
 - When the parking brake switch is operated under the condition that the parking brake actuator is malfunction.
 - When the initial position adjustment of the parking brake actuator is incomplete.
 - When system mode is "Factory Mode".

CAUTION:

When vehicle is parked, selector lever is in the P position.

- When a malfunction occurs in the electric parking brake system, parking brake can be mechanically released. Refer to [Diagnosis Procedure](#).
- When parking brake must be released while the 12V battery negative terminal is disconnected, mechanically release it. Refer to [Diagnosis Procedure](#).
- When rear brake pad is ground or replaced, perform break-in operation. Refer to [REAR BRAKE PAD : Inspection](#).
- When rear disc rotor is ground or replaced, perform break-in operation. Refer to [REAR DISC ROTOR : Periodic Maintenance Operation](#).

PRECAUTIONS FOR REMOVING BATTERY TERMINAL : Precautions

RDE-001824891

- With the adoption of Auto ACC function, ACC power is automatically supplied by operating the Intelligent Key or remote keyless entry or by opening/closing the driver side door. In addition, ACC power is supplied even after the ignition switch is turned to the OFF position, i.e. ACC power is supplied for a certain fixed time.
- When disconnecting the 12V battery terminal, turn off the ACC power before disconnecting the 12V battery terminal, observing “How to disconnect 12V battery terminal” described below.

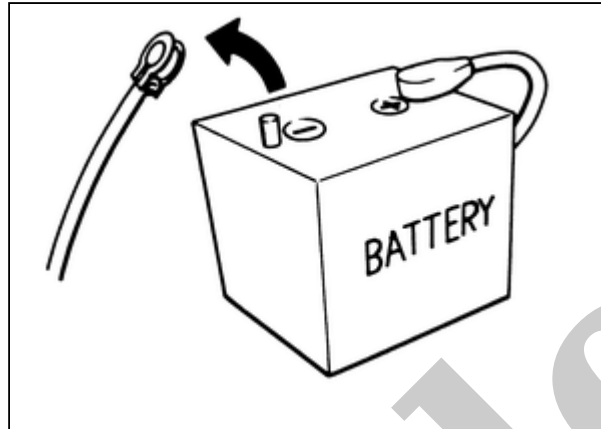

RDE-001824891-01-EF289H



NOTE:

ECU may be active for several minutes after the power switch is turned OFF. If the battery terminal is removed before ECU stops, then a DTC detection error or ECU data corruption may occur.

- Disconnect 12V battery terminal according to the following steps. Even when the power switch is OFF, the 12V battery automatic charge control may automatically start.

CAUTION:

Do not remove the battery during the update as the software update cannot be completed normally if the battery is removed during the software update.

WORK PROCEDURE

1. Open the hood (LHD models) or the back door (RHD models).
2. Check that charge cable (including EVSE) is not connected to the charge port.



NOTE:

If charge cable (including EVSE) is connected, the air conditioning system may be automatically activated by the timer A/C function.

3. Turn the power switch OFF → ON → press the power switch for at least 2 seconds to turn the high voltage system OFF, and then check that the charging status indicator is not illuminated.



NOTE:

When the high voltage system is turned ON, the charging status indicator blinks green with a frequency of 1 second.

4. Get out of the vehicle. Close all doors {except the hood (LHD models) or the back door (RHD models)}.
5. Check that the combination meter turns OFF and wait for 5 minutes or more.

CAUTION:

While waiting, never operate the vehicle such as locking, opening, and closing doors. Violation of this caution results in the activation of ACC power supply according to the Auto ACC function.



NOTE:

If the battery is removed within 5 minutes after the power switch is turned OFF, plural DTCs may be detected.

6. Check that the followings are not illuminated.

- Charging status indicator
- Electric parking brake warning lamp

7. Remove 12V battery terminal within 60 minutes after the power switch is turned OFF at Step 3.

CAUTION:

- **After all doors (including hood and back door) are closed, if a door (including hood and back door) is opened before battery terminals are disconnected, start over from Step 3.**
- **After turning the power switch OFF, if “Remote A/C” is activated by user operation, stop the air conditioner and start over from Step 3.**



NOTE:

Once the power switch is turned ON → OFF, the 12V battery automatic charge control does not start for approximately 1 hour.

- For vehicles with the 2-batteries, be sure to connect the main battery and the sub battery before turning ON the power switch.



NOTE:

If the power switch is turned ON with any one of the terminals of main battery and sub battery disconnected, then DTC may be detected.

- After installing the 12V battery, always check "Self Diagnosis Result" of all ECUs and erase DTC.



NOTE:

The removal of 12V battery may cause a DTC detection error.

OPERATION PROHIBITION

WARNING:

- Parts with strong magnet is used in this vehicle.
- Technicians using a medical electric device such as pacemaker must never perform operation on the vehicle, as magnetic field can affect the device function by approaching to such parts.

NORMAL CHARGE PRECAUTION

WARNING:

- If a technician uses a medical electric device such as an implantable cardiac pacemaker or an implantable cardioverter defibrillator, the possible effects on the devices must be checked with the device manufacturer before starting the charge operation.
- As radiated electromagnetic wave generated by PDM (Power Delivery Module) at normal charge operation may affect medical electric devices, a technician using a medical electric device such as implantable cardiac pacemaker or an implantable cardioverter defibrillator must not approach motor room [PDM (Power Delivery Module)] at the hood-opened condition during normal charge operation.

PRECAUTION AT TELEMATICS SYSTEM OPERATION

WARNING:

- If a technician uses implantable cardiac pacemaker or implantable cardioverter defibrillator (ICD), avoid the device implanted part from approaching within approximately 220 mm (8.66 in) from interior/exterior antenna.
- The electromagnetic wave of TCU might affect the function of the implantable cardiac pacemaker or the implantable cardioverter defibrillator (ICD), when using the service, etc.
- If a technician uses other medical electric devices than implantable cardiac pacemaker or implantable cardioverter defibrillator (ICD), the electromagnetic wave of TCU might affect the function of the device. The possible effects on the devices must be checked with the device manufacturer before TCU use.

PRECAUTION AT INTELLIGENT KEY SYSTEM OPERATION

WARNING:

- If a technician uses implantable cardiac pacemaker or implantable cardioverter defibrillator (ICD), avoid the device implanted part from approaching within approximately 220 mm (8.66 in) from interior/exterior antenna.
- The electromagnetic wave of Intelligent Key might affect the function of the implantable cardiac pacemaker or the implantable cardioverter defibrillator (ICD), at door operation, at each request switch operation, or at engine starting.
- If a technician uses other medical electric devices than implantable cardiac pacemaker or implantable cardioverter defibrillator (ICD), the electromagnetic wave of Intelligent Key might affect the function of the device. The possible effects on the devices must be checked with the device manufacturer before Intelligent Key use.

PRECAUTIONS FOR SUPPLEMENTAL RESTRAINT SYSTEM (SRS) AIR BAG AND SEAT BELT PRE-TENSIONER : Precautions

RDE-001824893

The Supplemental Restraint System such as “AIR BAG” and “SEAT BELT PRE-TENSIONER”, used along with a front seat belt, helps to reduce the risk or severity of injury to the driver and front passenger for certain types of collisions.

Information necessary to service the system safely is included in the “SRS AIR BAG” and “SEAT BELT” sections of this Service Manual.

WARNING:

Always observe the following items for preventing accidental activation:

- To avoid rendering the SRS inoperative, which could increase the risk of personal injury or death in the event of a collision that would result in air bag inflation, it is recommended that all maintenance and repair be performed by an authorized NISSAN/INFINITI dealer.
- Improper repair, including incorrect removal and installation of the SRS, can lead to personal injury caused by unintentional activation of the system. For removal of Spiral Cable and Air Bag Module, see “SRS AIR BAG”.
- Never use electrical test equipment on any circuit related to the SRS unless instructed to in this Service Manual. SRS wiring harnesses can be identified by yellow and/or orange harnesses or harness connectors.

PRECAUTIONS WHEN USING POWER TOOLS (AIR OR ELECTRIC) AND HAMMERS

WARNING:

Always observe the following items for preventing accidental activation:

- When working near the Air Bag Diagnosis Sensor Unit or other Air Bag System sensors with the ignition/power switch ON or engine running, never use air or electric power tools or strike near the sensor(s) with a hammer. Heavy vibration could activate the sensor(s) and deploy the air bag(s), possibly causing serious injury.
- When using air or electric power tools or hammers, always switch the ignition/power switch OFF, disconnect the 12V battery or batteries, and wait at least 3 minutes before performing any service.

PARKING BRAKE SYSTEM : Commercial Service Tools or/and Repair Part

Electric Parking Brake System

RDE-001824883

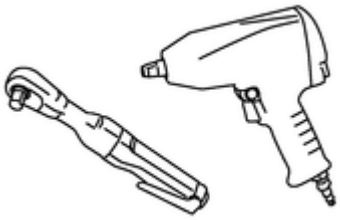
Tool name		Description
Power tool	 <p>RDE-000655272-01-BIC0190E</p>	Loosening bolts and nuts

Sample

Wiring Diagram

Click link to [Wiring Diagram](#).

Sample

Refer to [Work Procedure](#).

Sample

Refer to [Work Procedure](#).

Sample