

# Your Ultimate Source for OEM Repair Manuals

FactoryManuals.net is a great resource for anyone who wants to save money on repairs by doing their own work. The manuals provide detailed instructions and diagrams that make it easy to understand how to fix a vehicle.

## 2002 VOLVO V40 OEM Service and Repair Workshop Manual

[Go to manual page](#)

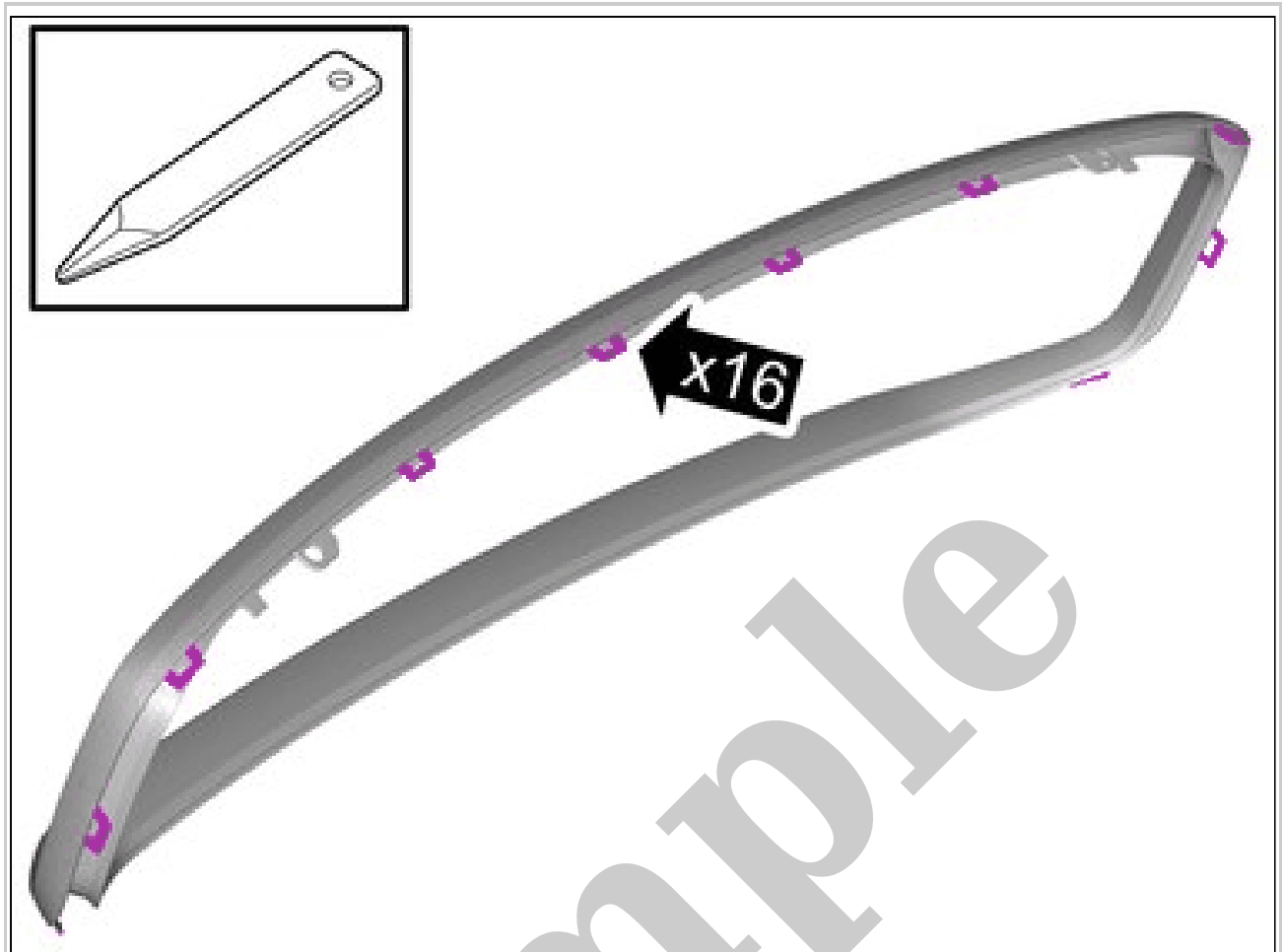

Courtesy of VOLVO CARS CORPORATION

**NOTE:** *The graphic shows the back of the component before removal.*

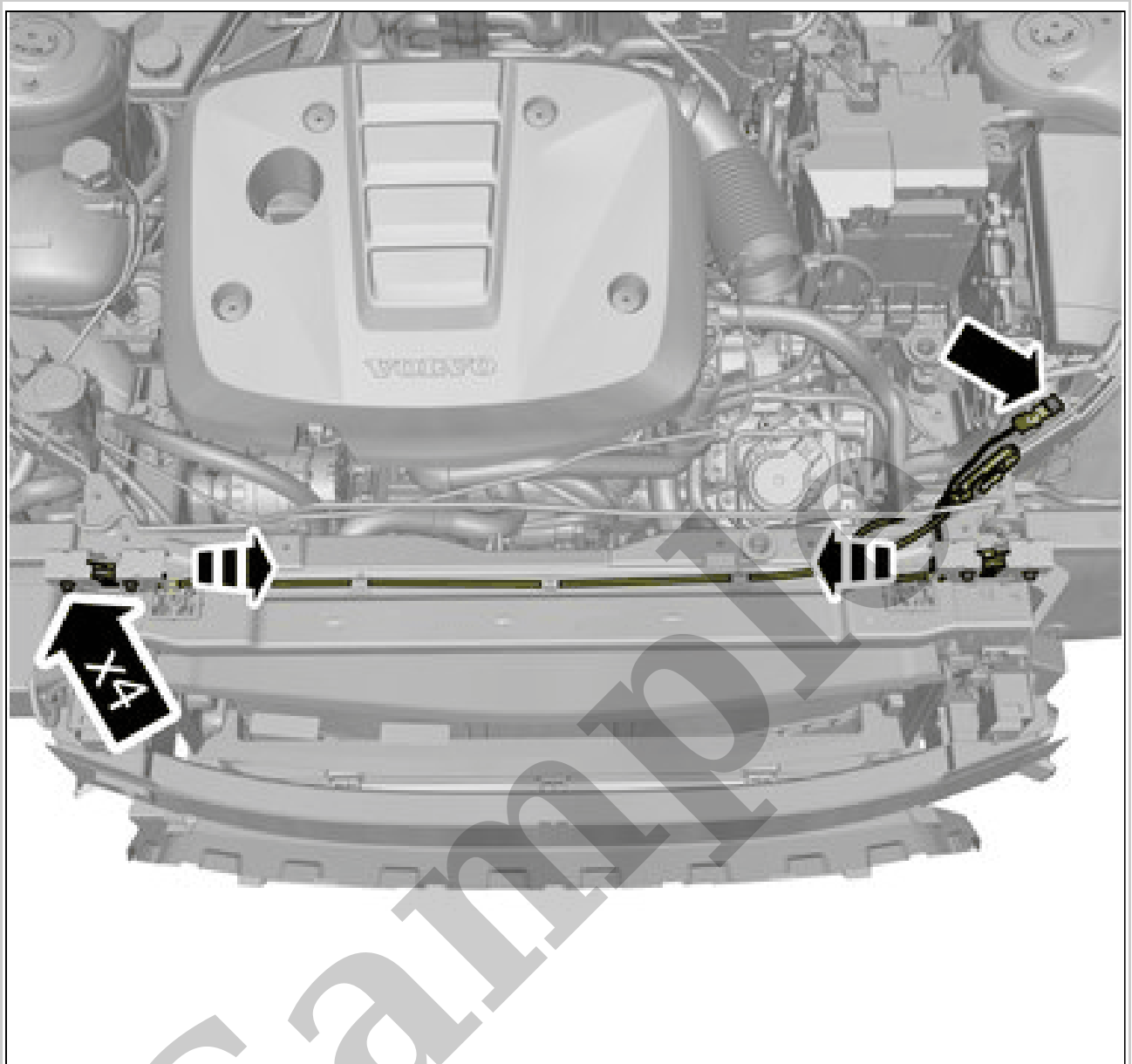

Courtesy of VOLVO CARS CORPORATION

- Remove the screws.
- Loosen the clip.
- Disconnect the connector.
- Fold marked part aside.

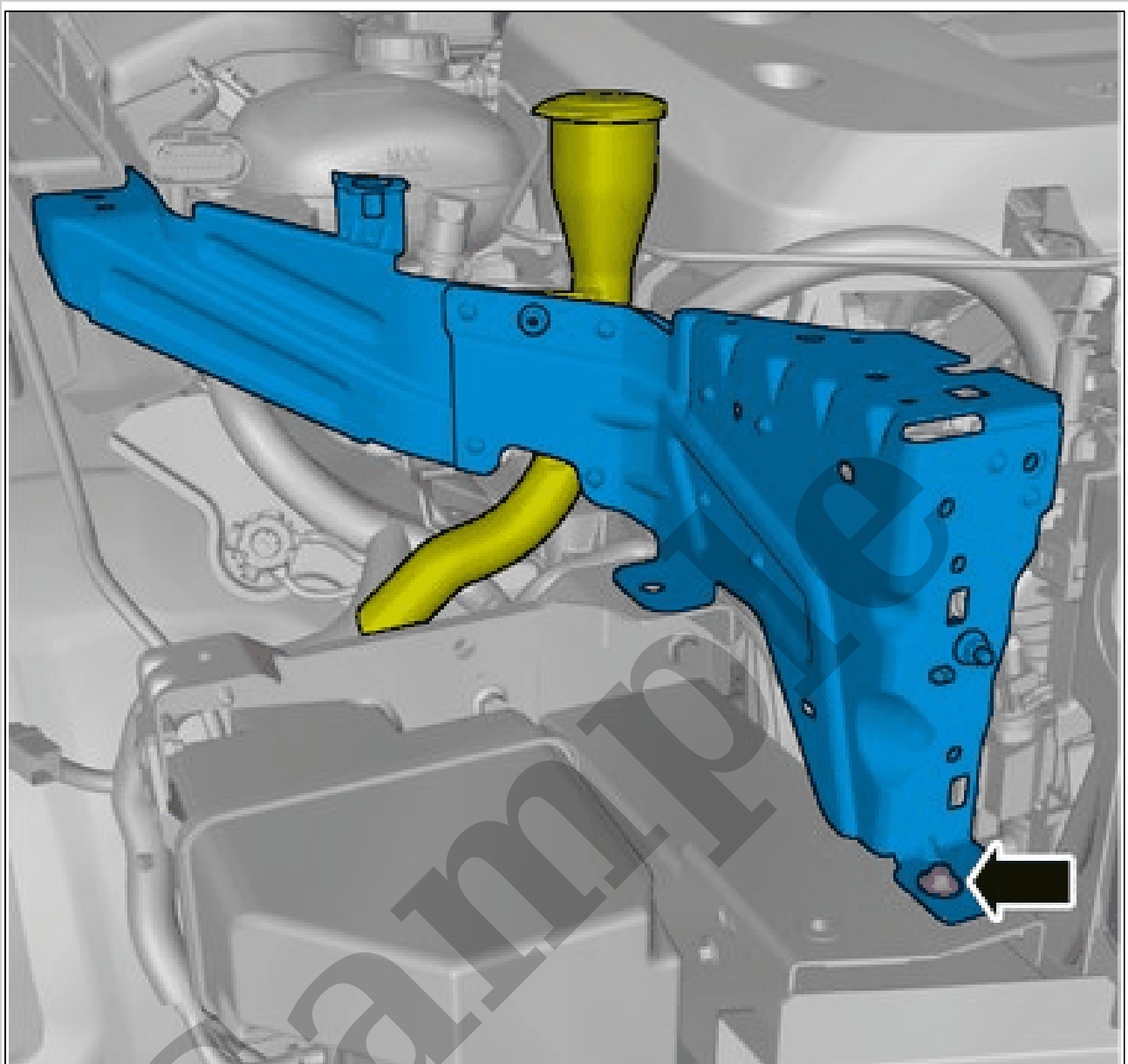

Courtesy of VOLVO CARS CORPORATION

Remove the screw.  
Remove the marked part.  
**Torque:** M6, 10Nm

Remove the headlamp. Refer to: HEADLAMPS



Courtesy of VOLVO CARS CORPORATION

**NOTE:** *The graphic shows the back of the component before removal.*

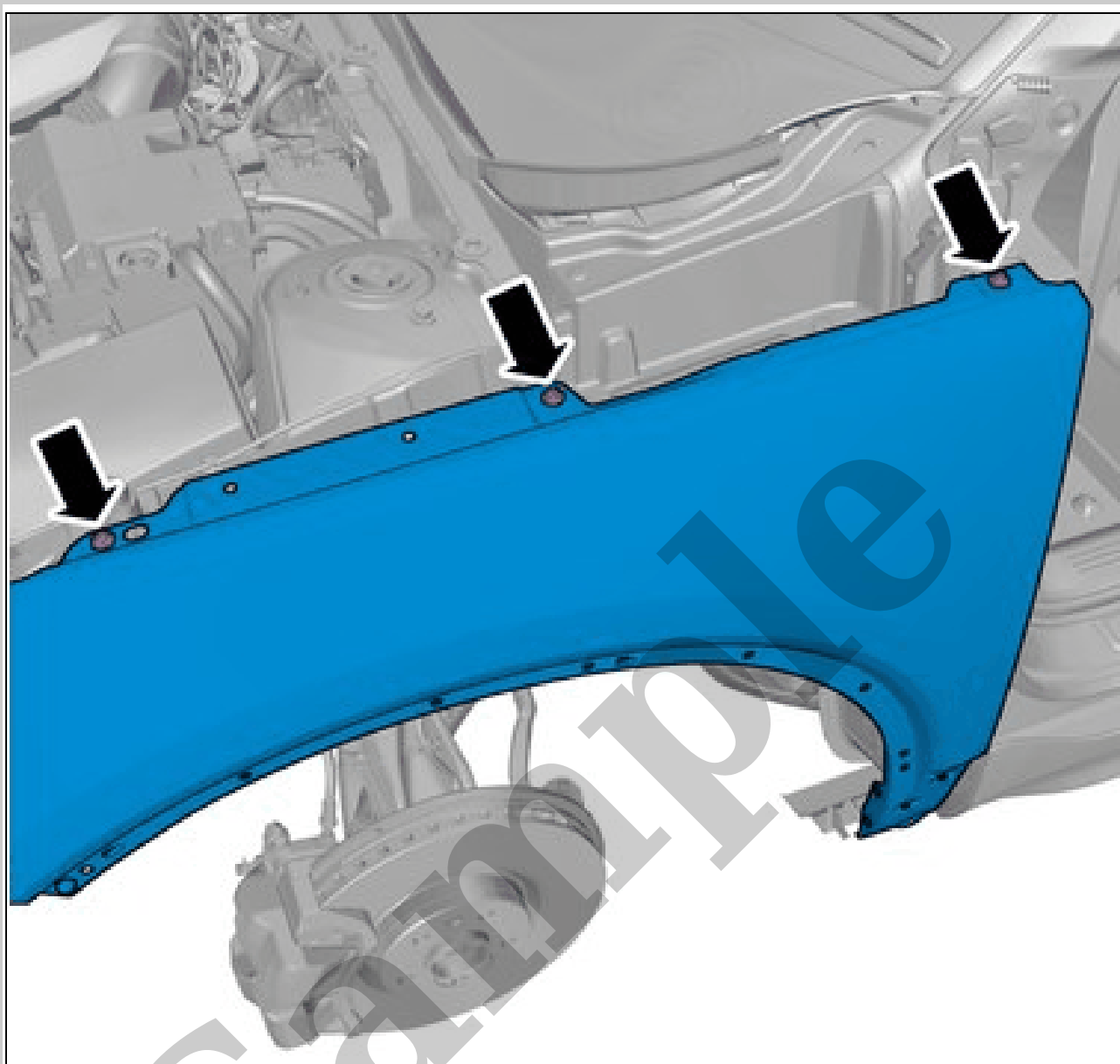

Courtesy of VOLVO CARS CORPORATION

Remove the screws.

Remove the marked part.

**Torque:** M6, 10Nm

See information about paint. Refer to: PAINT

See information about corrosion protection. Refer to: RUSTPROOFING

## **FENDER FRONT > FENDER FRONT [2018-2022] > INSTALLATION**

To install, reverse the removal procedure.

## **FENDER REAR > FENDER REAR [2018-2022] > REMOVAL**

See information on welding, general. Refer to: WELDING, GENERAL

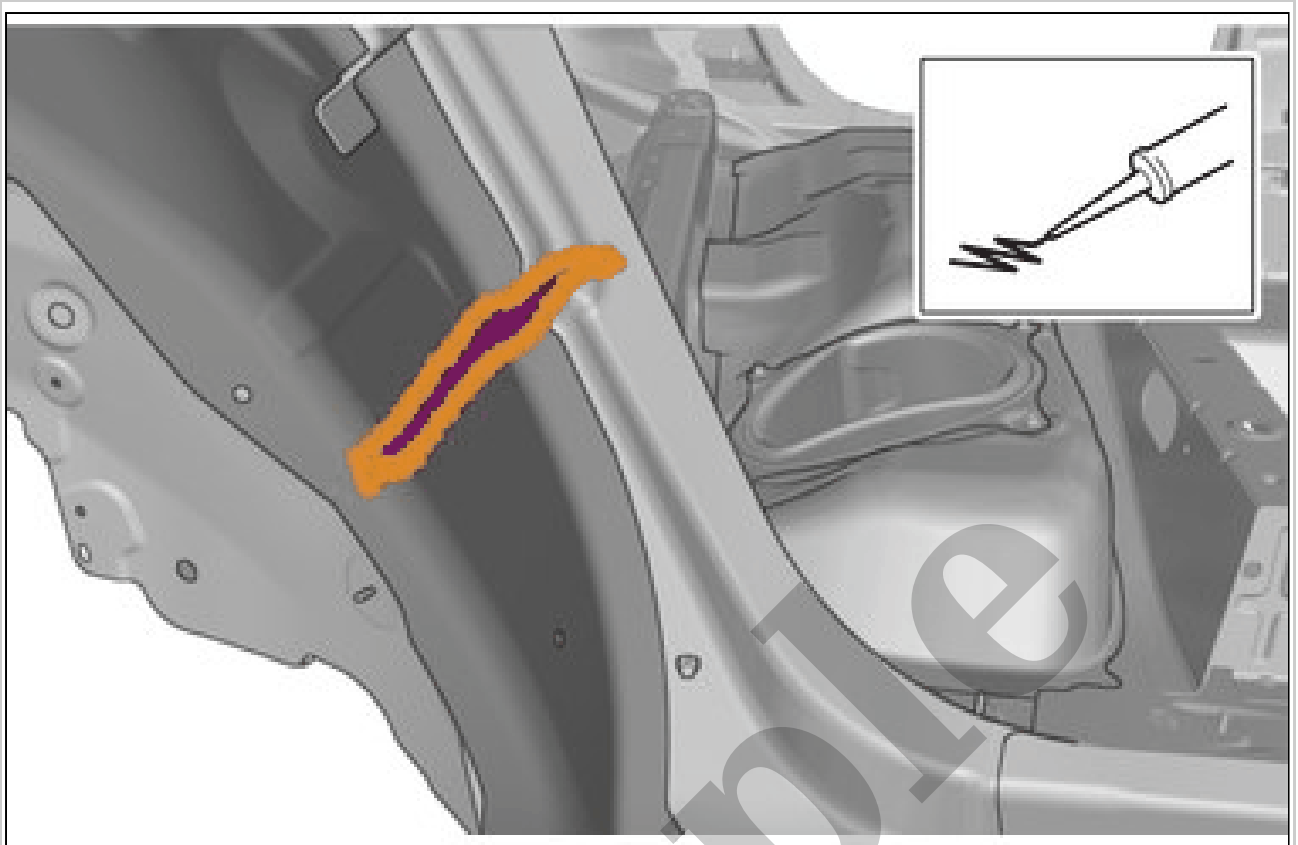

Courtesy of VOLVO CARS CORPORATION

Sample



Courtesy of VOLVO CARS CORPORATION

### Component overview



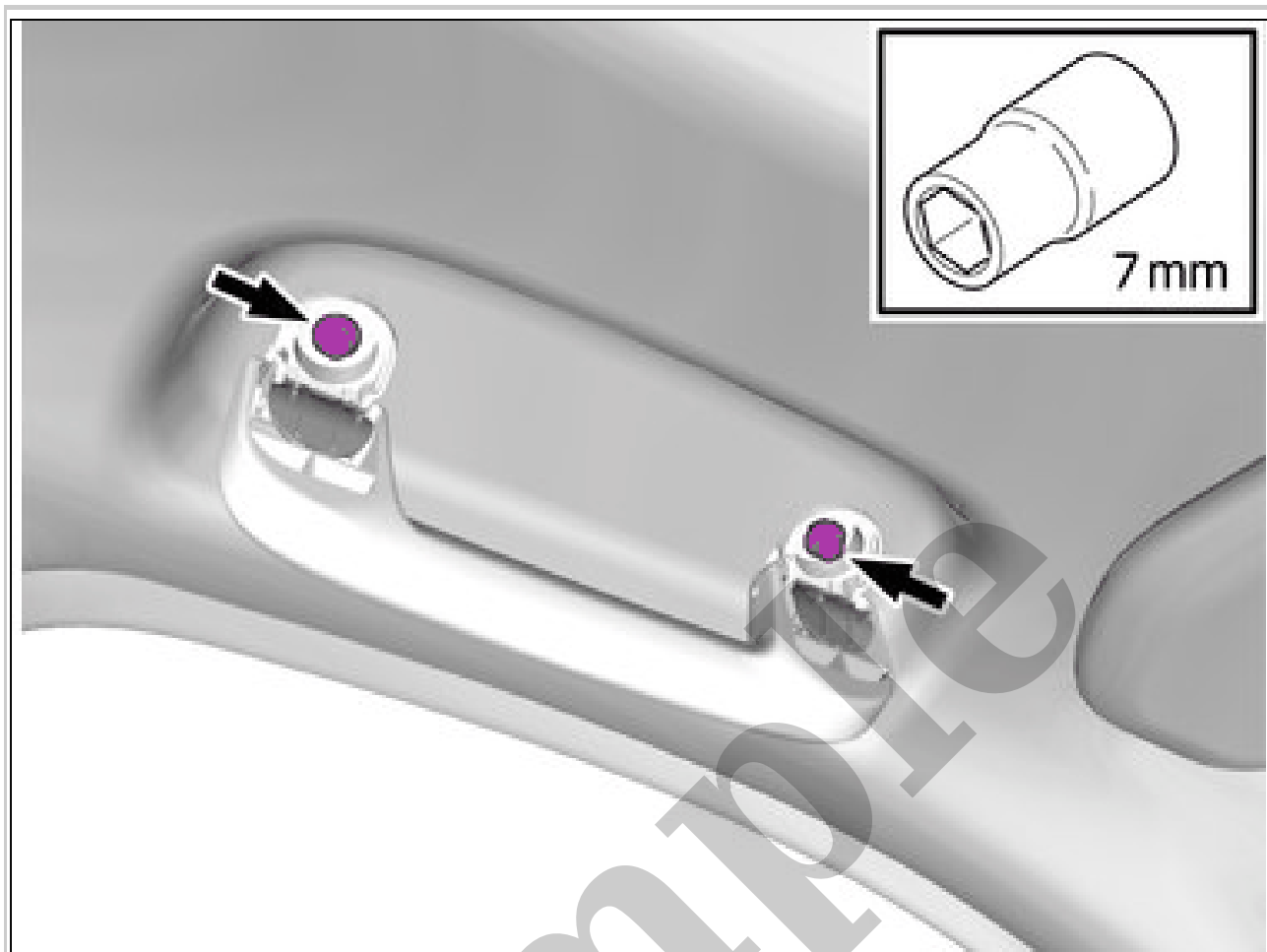

Courtesy of VOLVO CARS CORPORATION

**NOTE:** *The screws are to be reused.*

Remove the screws.

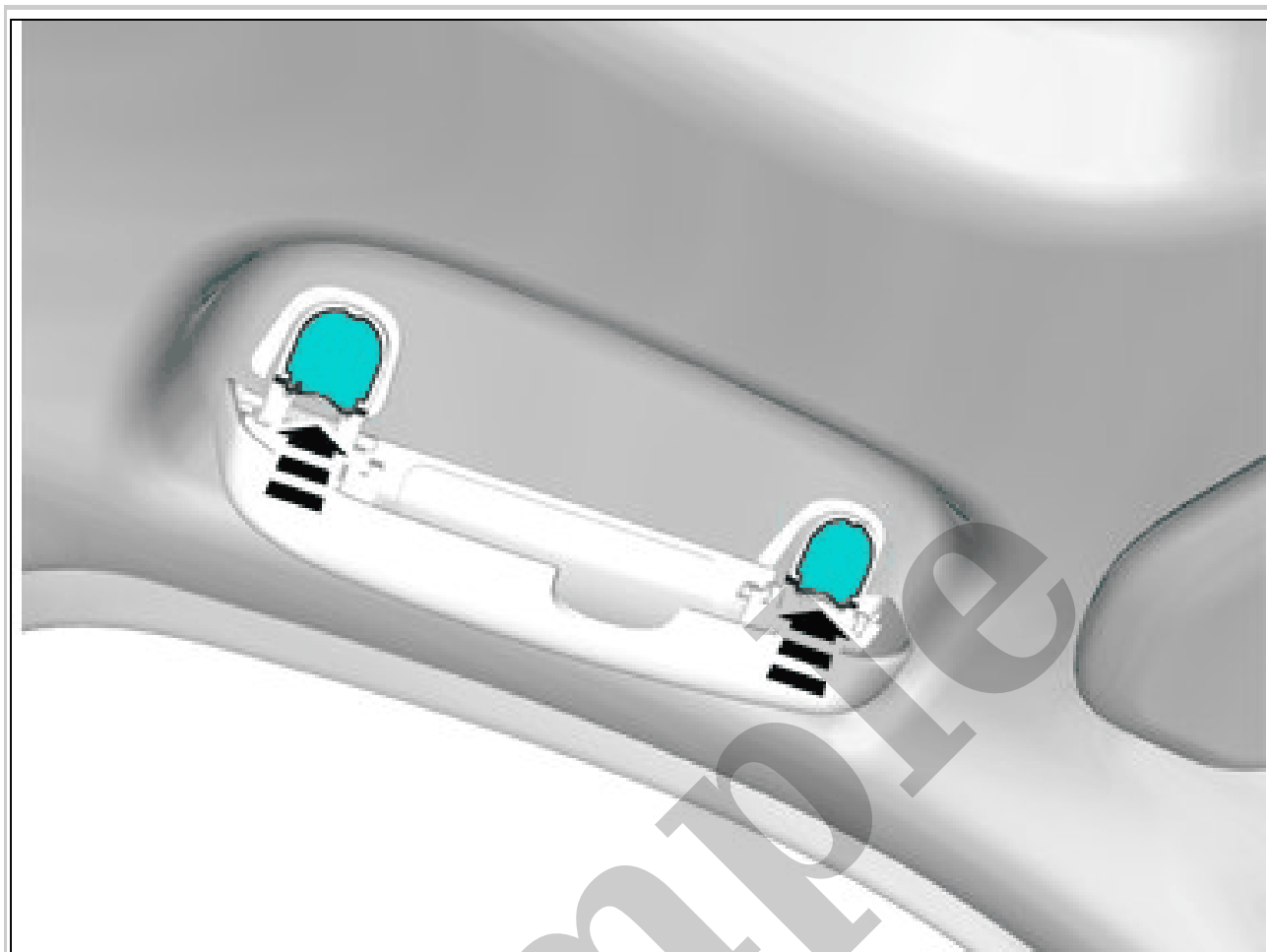

Courtesy of VOLVO CARS CORPORATION

## **PROTECTIVE GRILLE, STEEL > PROTECTIVE GRILLE, STEEL [2018-2022] > ACCESSORY INSTALLATION**

**Component overview**