

Your Ultimate Source for OEM Repair Manuals

FactoryManuals.net is a great resource for anyone who wants to save money on repairs by doing their own work. The manuals provide detailed instructions and diagrams that make it easy to understand how to fix a vehicle.

2001 VOLVO S80 OEM Service and Repair Workshop Manual

[Go to manual page](#)

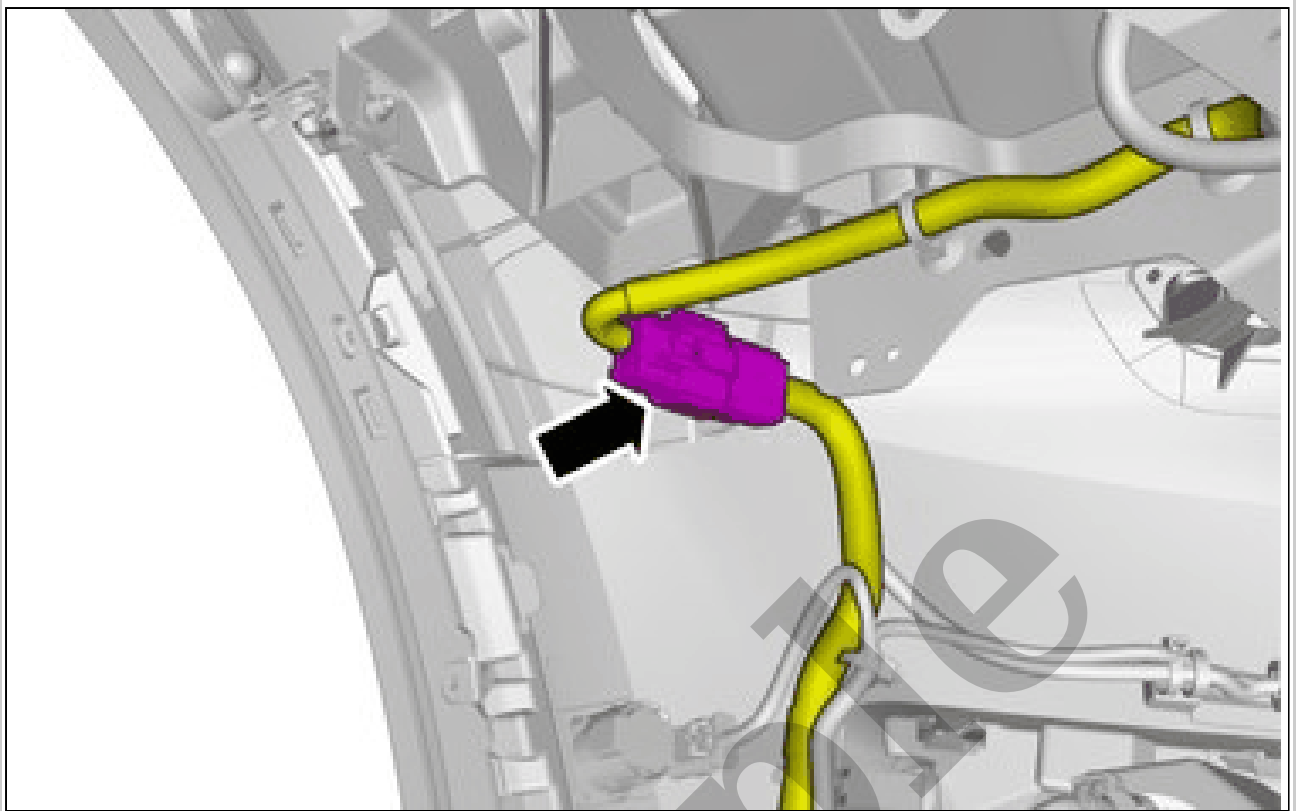

Courtesy of VOLVO CARS CORPORATION

Left-hand side
Disconnect the connector.

NOTE: Removal steps in this procedure may contain installation details.

Remove the front wheels. Refer to: WHEELS

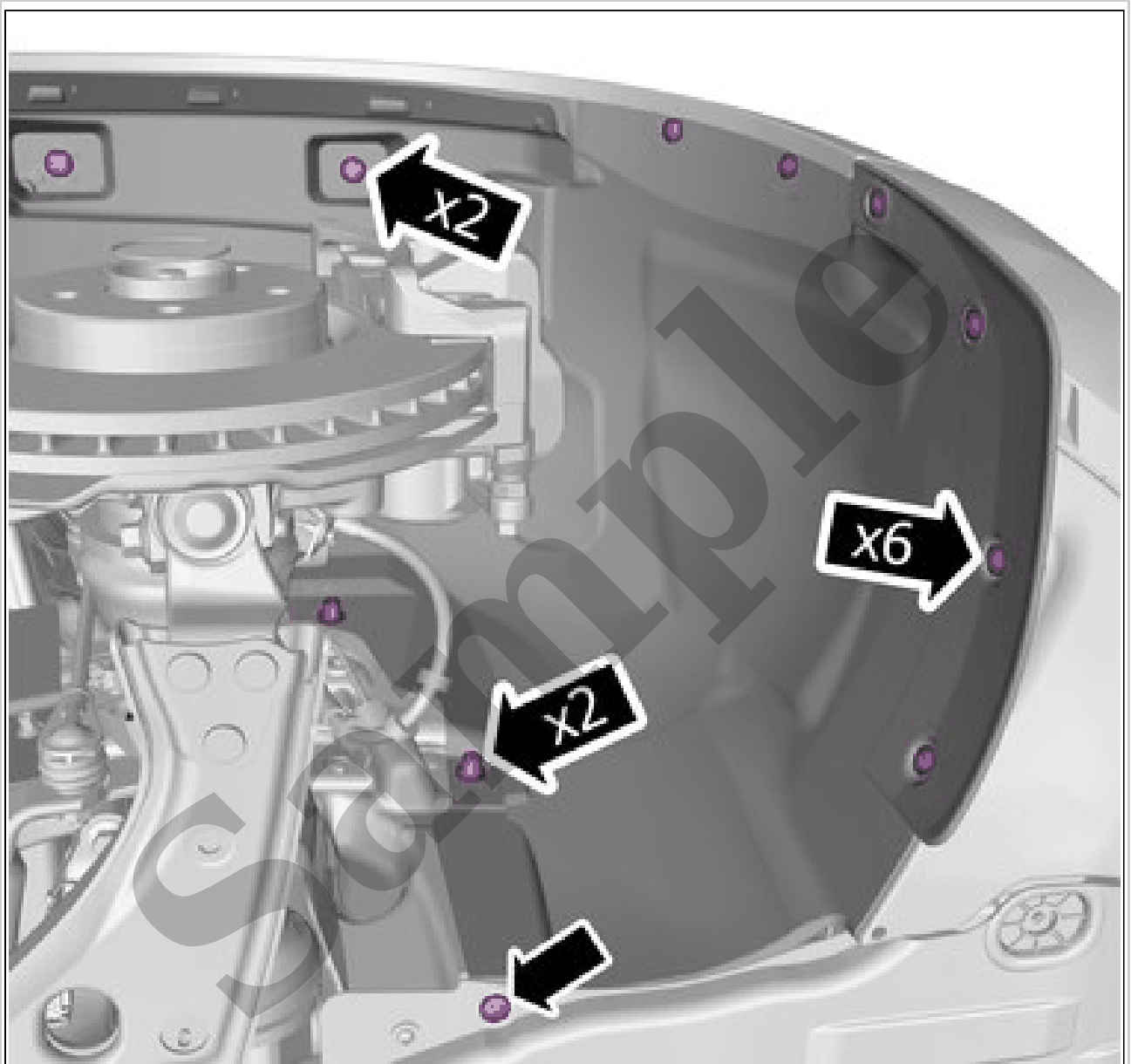

Courtesy of VOLVO CARS CORPORATION

Remove the screws.
Loosen the clip.
Remove the nuts.
On both sides.

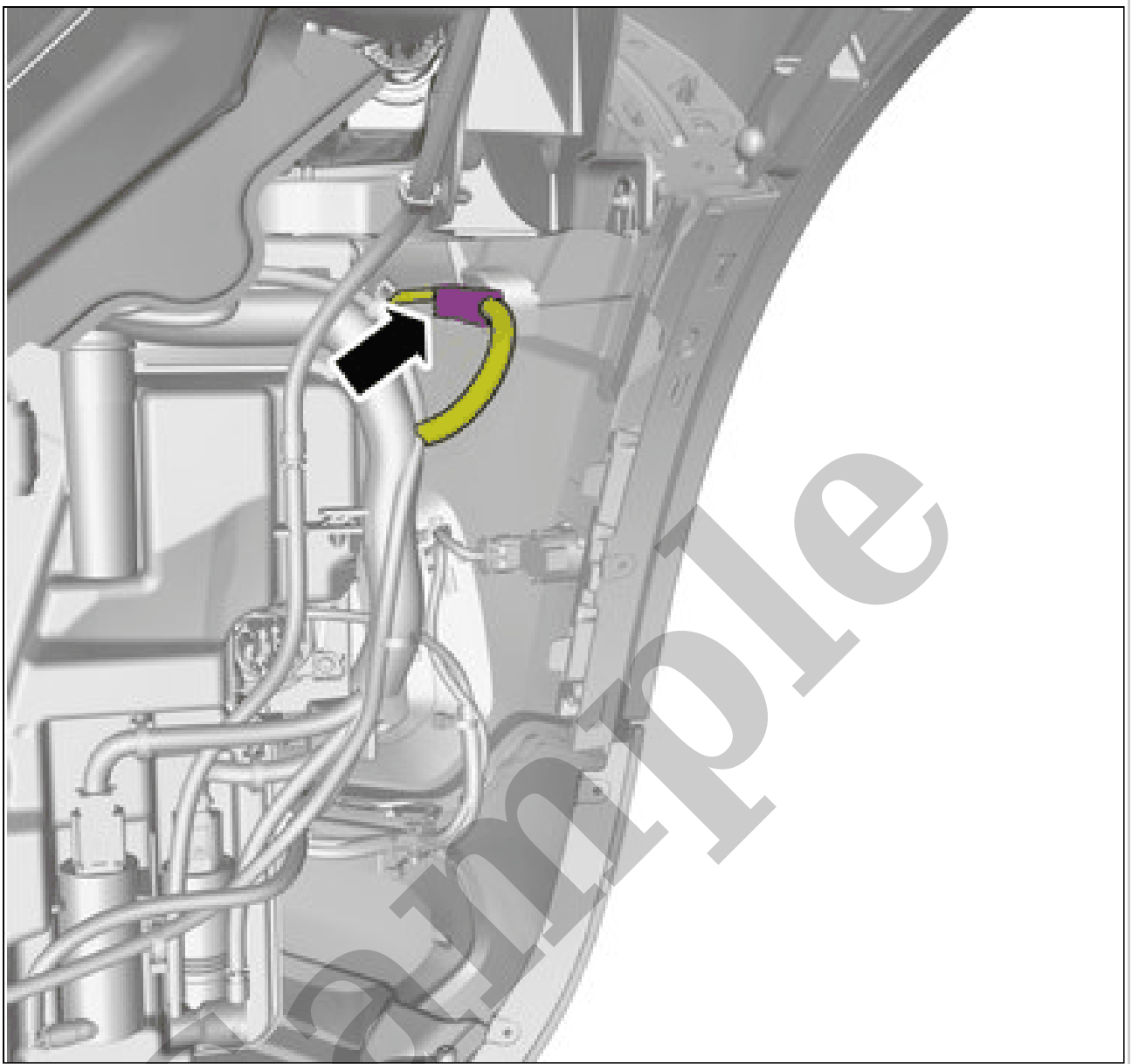

Courtesy of VOLVO CARS CORPORATION

Disconnect the connector.

COVER BUMPER REAR > COVER BUMPER REAR [2021-2022, E400V6] > REMOVAL AND INSTALLATION

REMOVAL

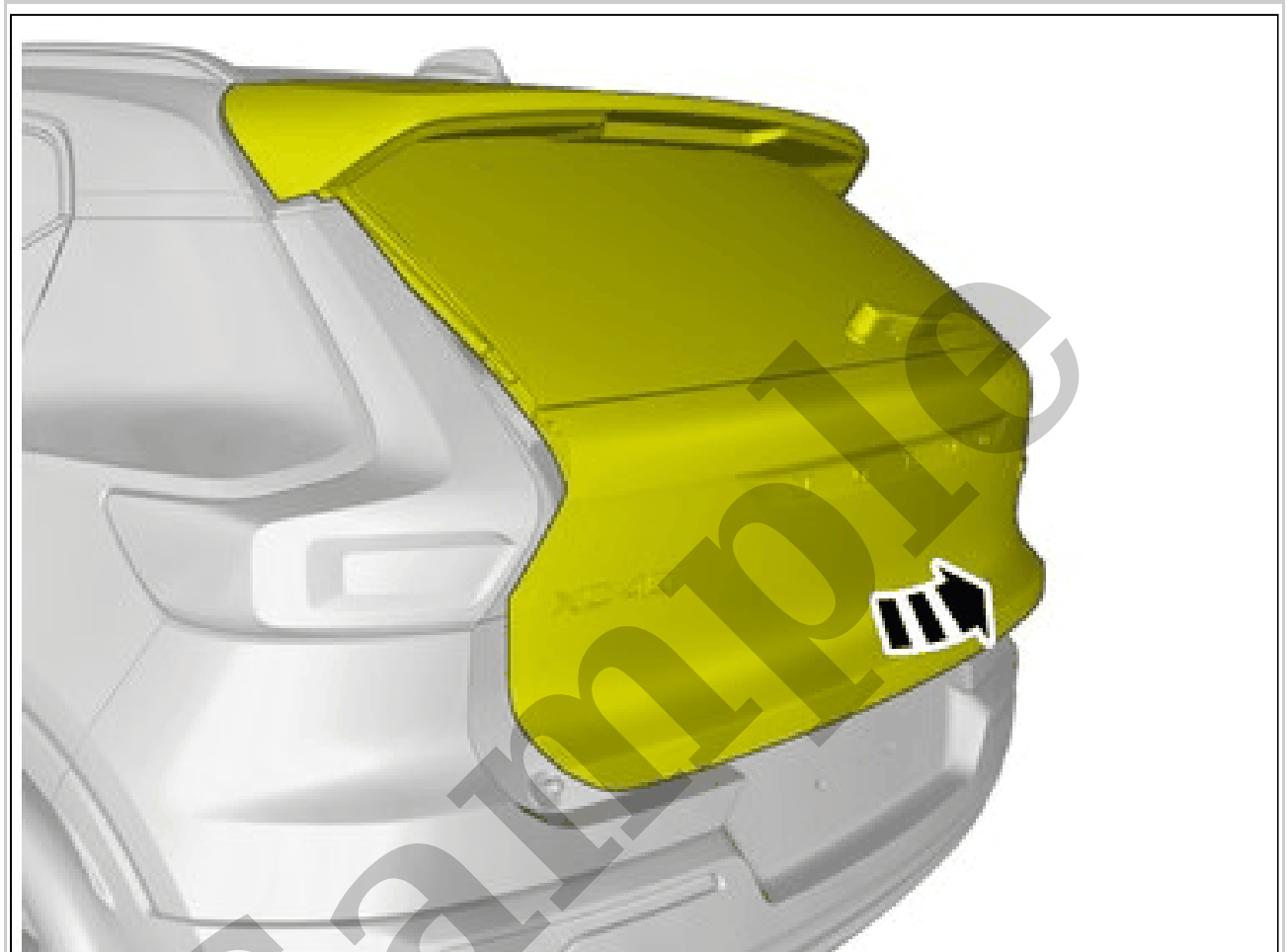

Courtesy of VOLVO CARS CORPORATION

Open the tailgate.

Set the vehicle to Inactive mode, described in user mode. Refer to: USAGE MODE

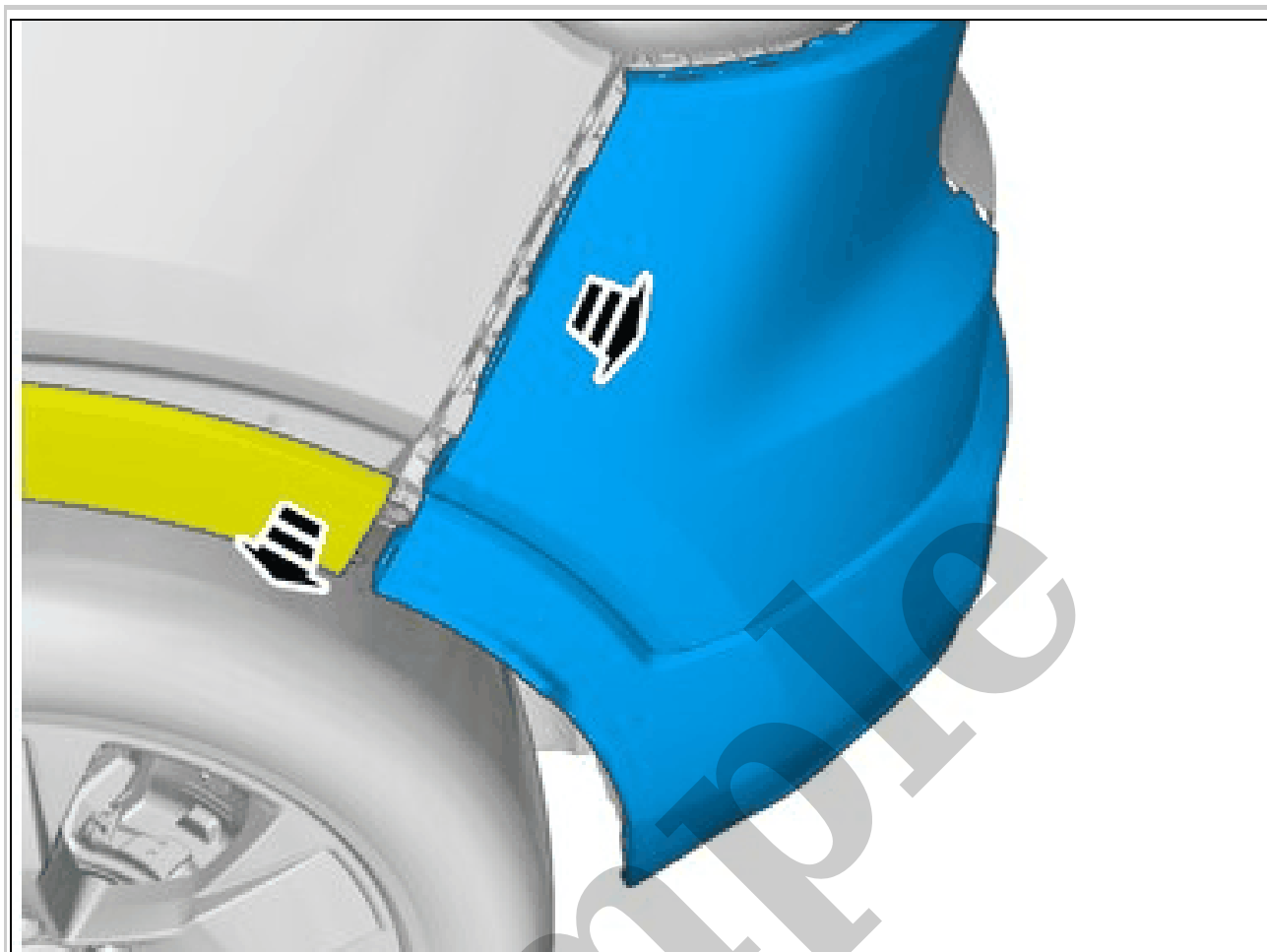

Courtesy of VOLVO CARS CORPORATION

CAUTION: *Be extra careful when removing or installing this component.*

Loosen the component indicated. Do not remove it.

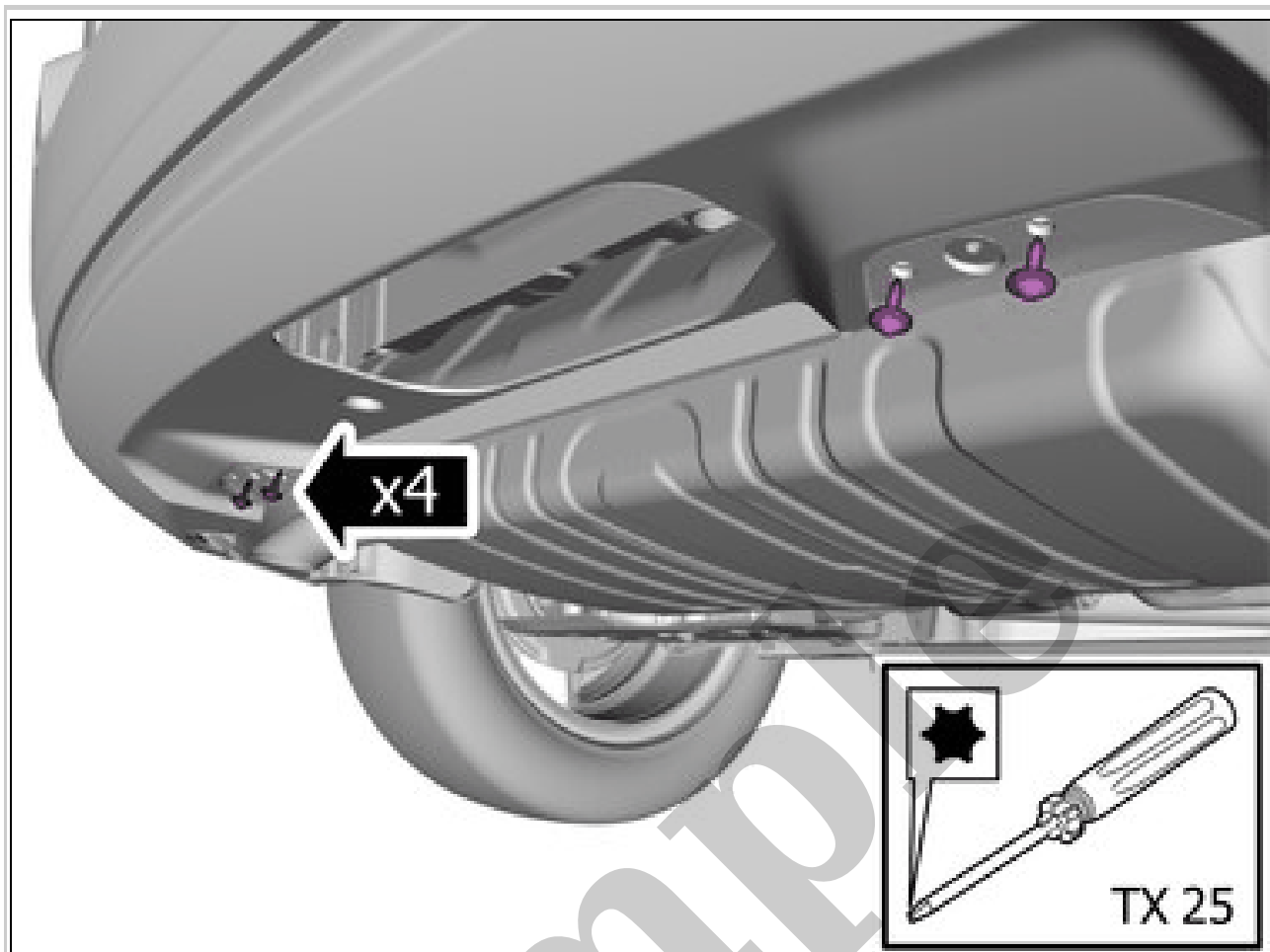

Courtesy of VOLVO CARS CORPORATION

Remove the screws.

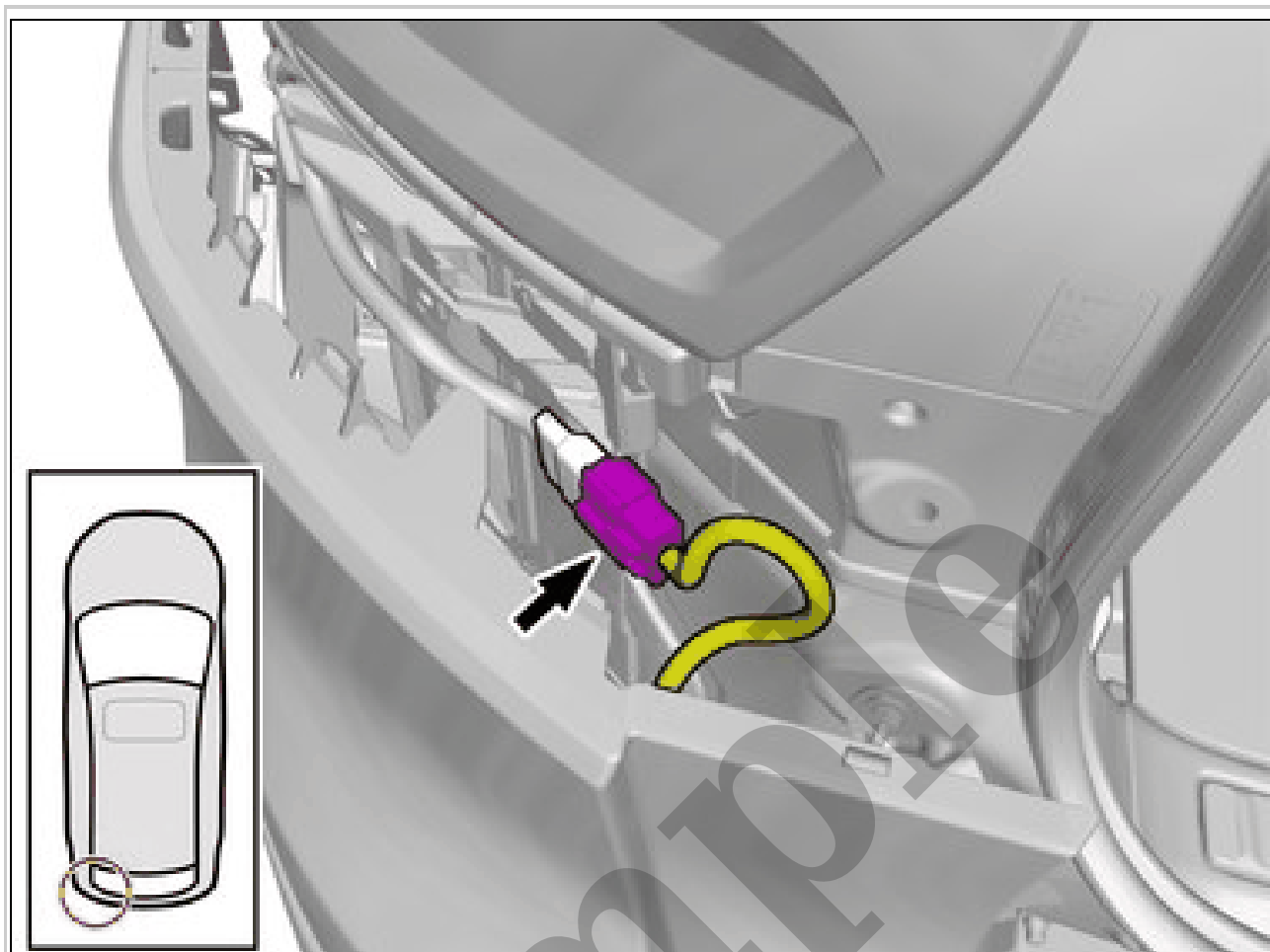

Courtesy of VOLVO CARS CORPORATION

Disconnect the connector.

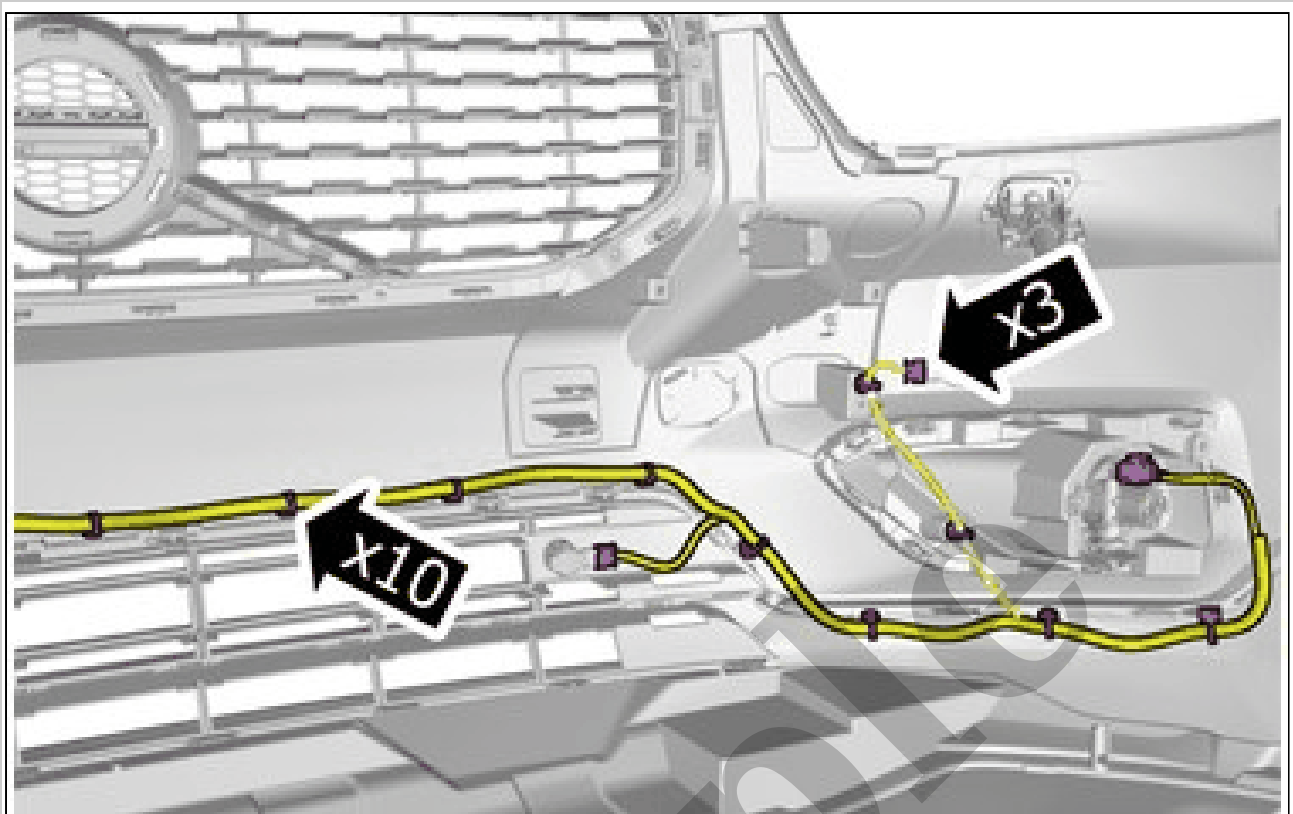

Courtesy of VOLVO CARS CORPORATION

NOTE: *The number of connectors may vary depending on the vehicle's equipment level.*

Disconnect the connectors.
Remove the cable harness clips.

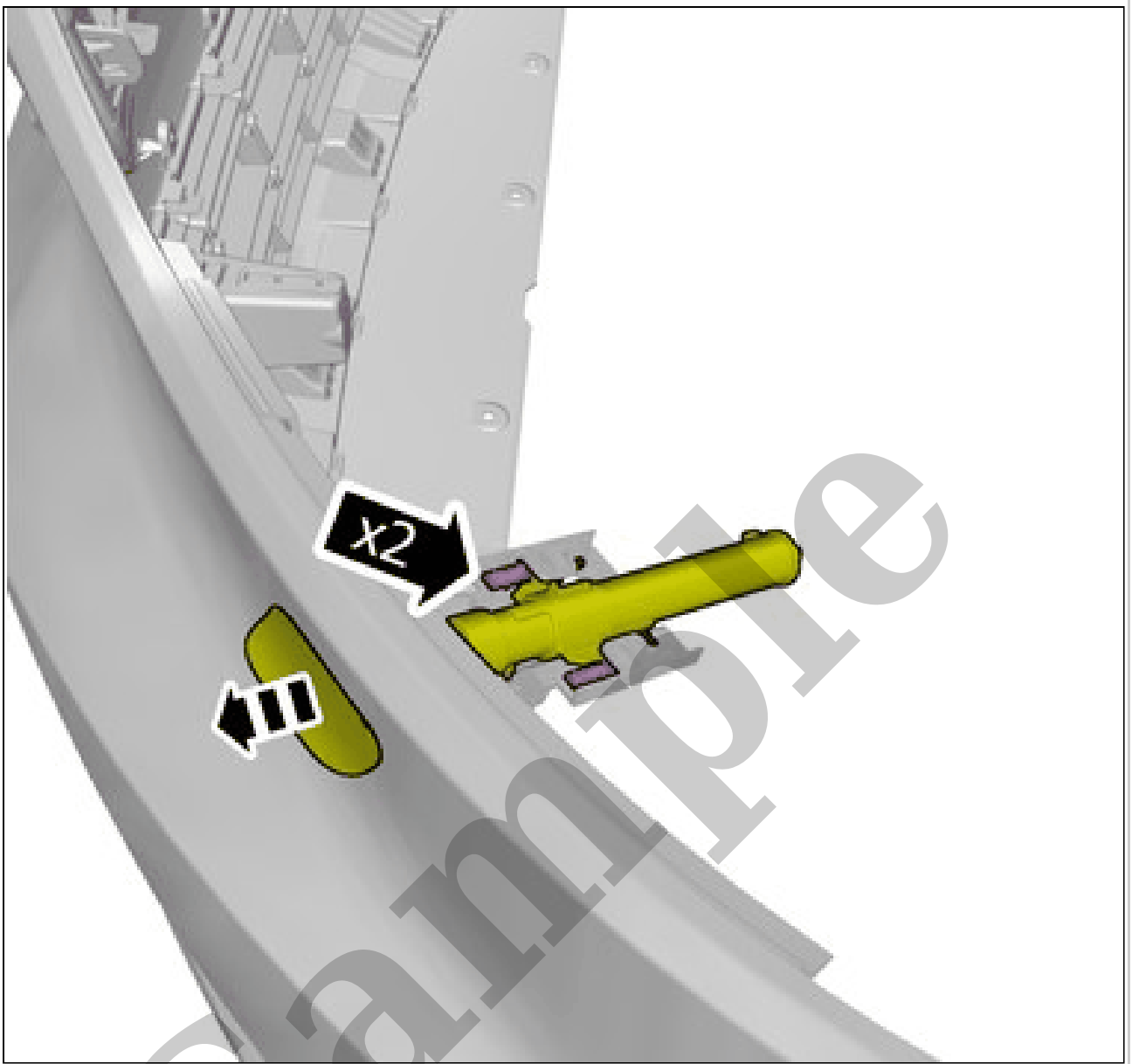

Courtesy of VOLVO CARS CORPORATION

Remove the part carefully
On both sides.