

# Your Ultimate Source for OEM Repair Manuals

FactoryManuals.net is a great resource for anyone who wants to save money on repairs by doing their own work. The manuals provide detailed instructions and diagrams that make it easy to understand how to fix a vehicle.

## 2001 FORD Ranger Super Cab OEM Service and Repair Workshop Manual

[Go to manual page](#)

[Click here to learn about symbols, color coding, and icons used in this manual.](#)

3. Apply adhesive (each side).

**Material** : Metal Bonding Adhesive / TA-1, TA-1-B, 3M™ 08115, LORD Fusor® 108B, Henkel Teroson EP 5055

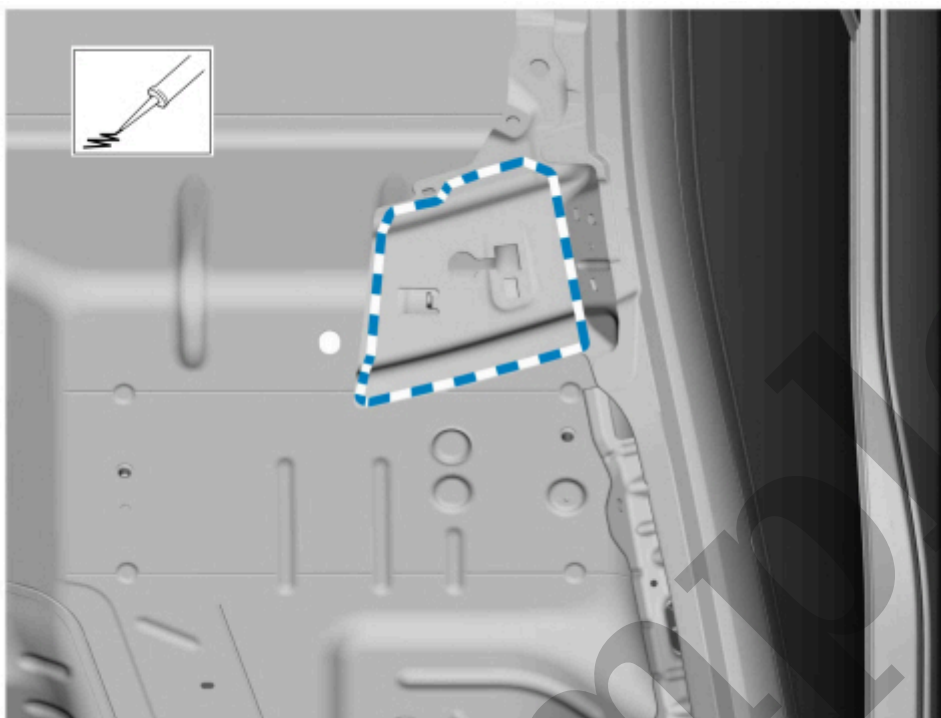

E191845

[Click here to learn about symbols, color coding, and icons used in this manual.](#)

4. Install and clamp the roof front frame.

Use the General Equipment: Locking Pliers

6. **NOTE**

SPR (self-piercing rivet) fasteners may not be placed directly over original SPR (self-piercing rivet) location. They must be placed adjacent to original location matching original quantity.

**NOTE**

Solid or blind rivets may be used in place of SPR (self-piercing rivet) fasteners in the original SPR (self-piercing rivet) location after enlarging hole to 6.5 mm.

Install fasteners (both sides).

| Item | SPR (self-piercing rivet) Number | SPR (self-piercing rivet) Code | Henrob® Mandrel | Pro-Spot® Mandrel | Blind Rivet   | Solid Rivet  | Rivnut® |
|------|----------------------------------|--------------------------------|-----------------|-------------------|---------------|--------------|---------|
| 1    | W710246-S900                     | BN                             | DP10-200/H      | SA-0400/SA-0402   | -             | W790377-S900 | -       |
| 2    | -                                | -                              | -               | -                 | W708777-S900C | -            | -       |

Use the General Equipment: Blind Rivet Gun

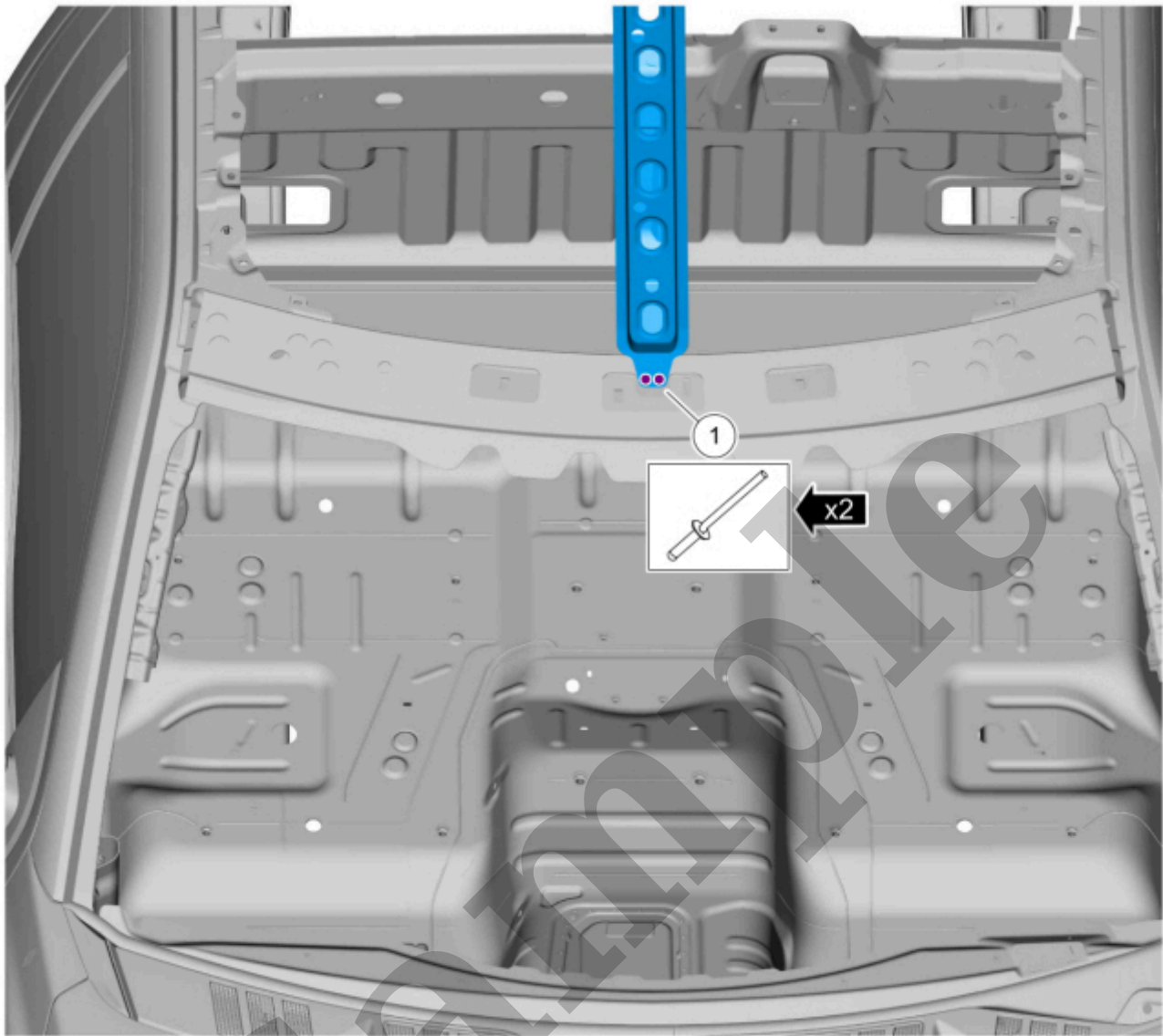

E191849

[Click here to learn about symbols, color coding, and icons used in this manual.](#)

### All vehicles

8. Install the roof outer panel.

Refer to: [Roof Panel - Regular Cab](#)(501-28 Roof Sheet Metal Repairs, Removal and Installation).

Refer to: [Roof Panel - SuperCab](#)(501-28 Roof Sheet Metal Repairs, Removal and Installation).

Refer to: [Roof Panel - SuperCrew](#)(501-28 Roof Sheet Metal Repairs, Removal and Installation).

Refer to: [Roof Panel - Regular Cab](#)(501-28 Roof Sheet Metal Repairs, Removal and Installation).

## Roof Panel - Regular Cab

|                                        |                                           |
|----------------------------------------|-------------------------------------------|
| <b>501-28 Roof Sheet Metal Repairs</b> | <b>2022 F-150</b>                         |
| <b>Removal and Installation</b>        | <b>Procedure revision date: 10/8/2020</b> |

### Roof Panel - Regular Cab

#### Removal

##### WARNING

Electric vehicles damaged by a crash may have compromised high voltage safety systems and present a potential high voltage electrical shock hazard. Exercise caution and wear appropriate Personal Protective Equipment (PPE) safety gear, including high voltage safety gloves and boots. Remove all metallic jewelry, including watches and rings. Isolate the HV system as directed by the Ford Emergency Response Guide for the vehicle. Failure to follow these instructions may result in serious personal injury or death.

##### NOTICE

Battery electric vehicle (BEV), hybrid electric vehicle (HEV) and plug-in hybrid electric vehicle (PHEV) contain a high-voltage battery. Before cutting or welding near the high-voltage battery it must be removed to avoid damage.

##### 1. WARNING

Before beginning any service procedure in this manual, refer to health and safety warnings in section 100-00 General Information. Failure to follow this instruction may result in serious personal injury.

Refer to: [Health and Safety Precautions](#)(100-00 General Information, Description and Operation).

Refer to: [Satellite Radio / Global Positioning System \(GPS\) Antenna Cable - Vehicles With: 8 Inch Center Display Screen/12 Inch Center Display Screen](#)(415-00 Information and Entertainment System - General Information, Removal and Installation).

9. Remove the roof ditch sealer.

Use the General Equipment: Hot Air Gun

Use the General Equipment: Scraper for Straight Edges

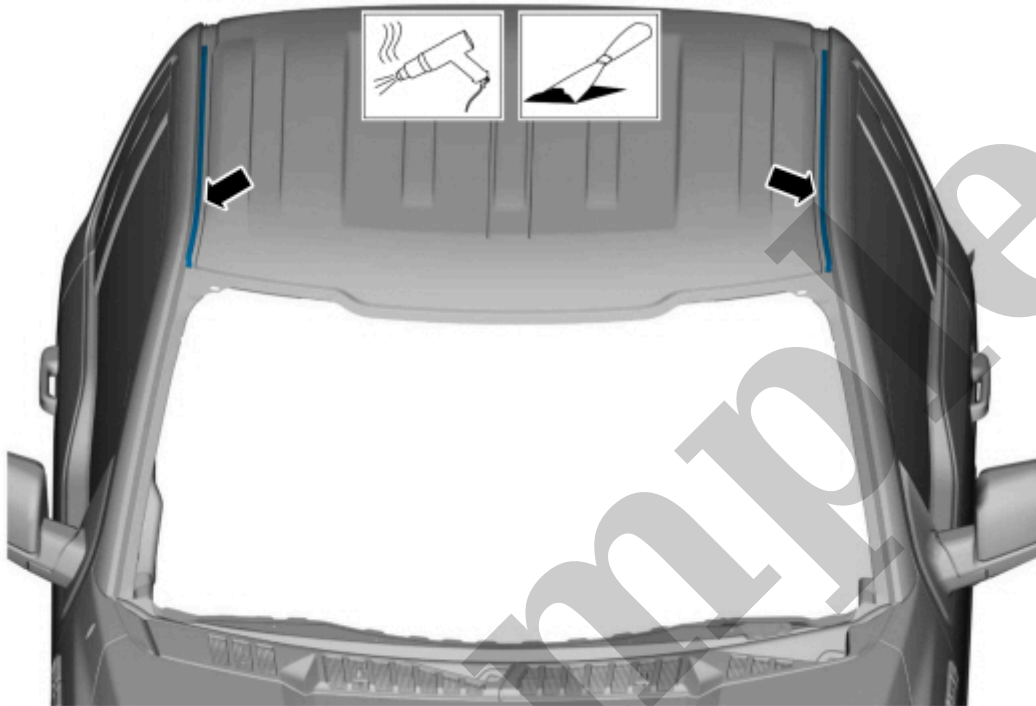

E191295

[Click here to learn about symbols, color coding, and icons used in this manual.](#)

10. Remove the front header SPR (self-piercing rivet) fasteners.

Use the General Equipment: Self-Piercing Rivet (SPR) Remover/Installer

Use the General Equipment: Belt Sander

[Click here to learn about symbols, color coding, and icons used in this manual.](#)

12. Carefully cut the roof

**outer panel only**

in the area shown (inboard on the roof ditch). Both sides.

Use the General Equipment: Air Body Saw

Use the General Equipment: Spherical Cutter

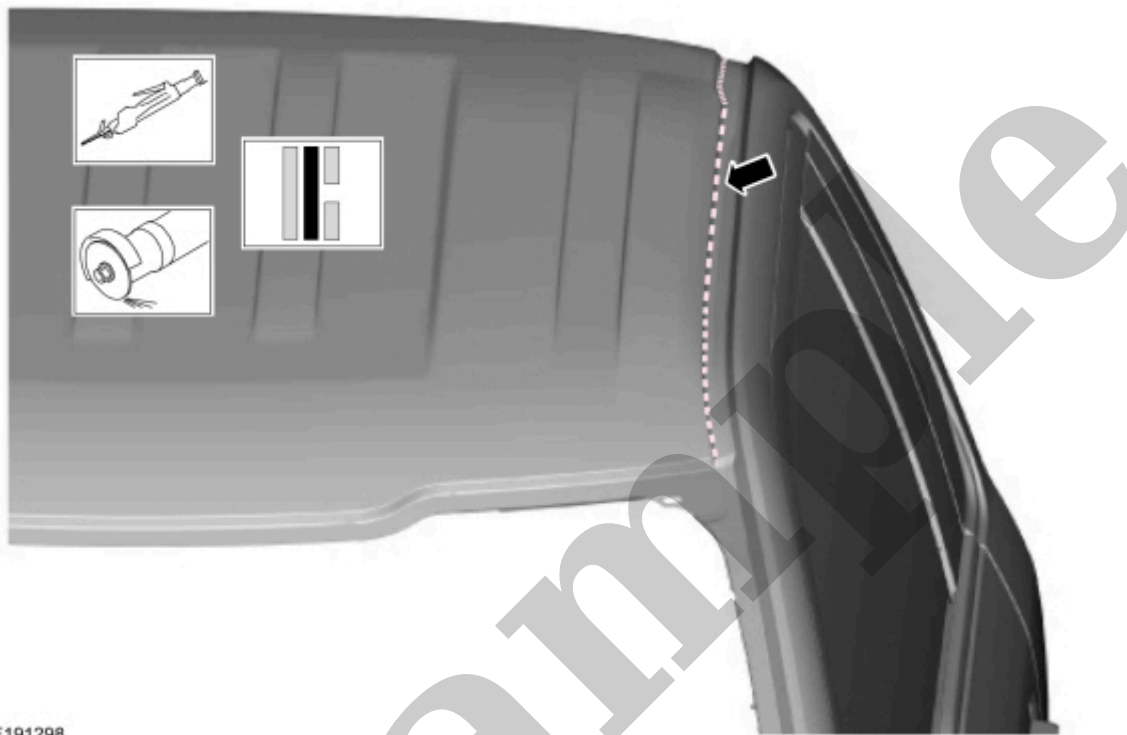

E191298

[Click here to learn about symbols, color coding, and icons used in this manual.](#)

13. Leave as much foam as possible intact on the roof bows.

Use the General Equipment: Knife

15. With the help of an assistant, remove the roof outer panel.

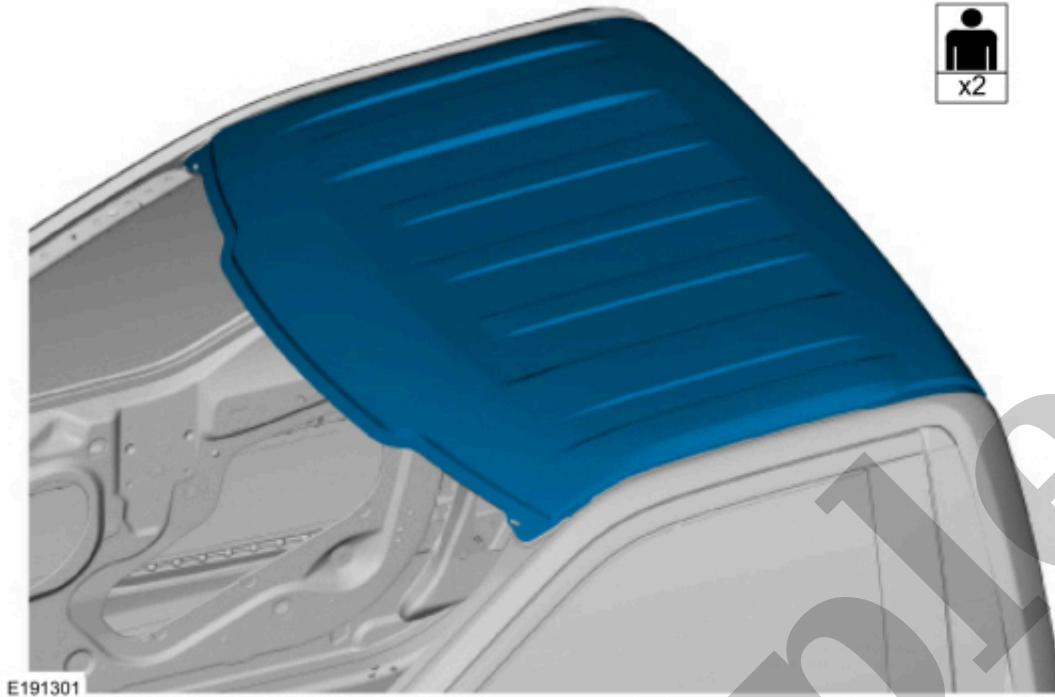

[Click here to learn about symbols, color coding, and icons used in this manual.](#)

16. **NOTE**

Carefully grind the area smooth removing remaining portions of the factory laser weld. use caution to avoid thinning of the metal.

Using a grinder or air chisel, carefully remove the remaining portion of the roof panel flange and laser weld bead.

Use the General Equipment: Grinder



Refer to: [Special Repair Considerations for Aluminum Repairs](#)(501-25 Body Repairs - General Information, Description and Operation).

2. Sand and clean the roof mating surfaces.

Use the General Equipment: Grinder

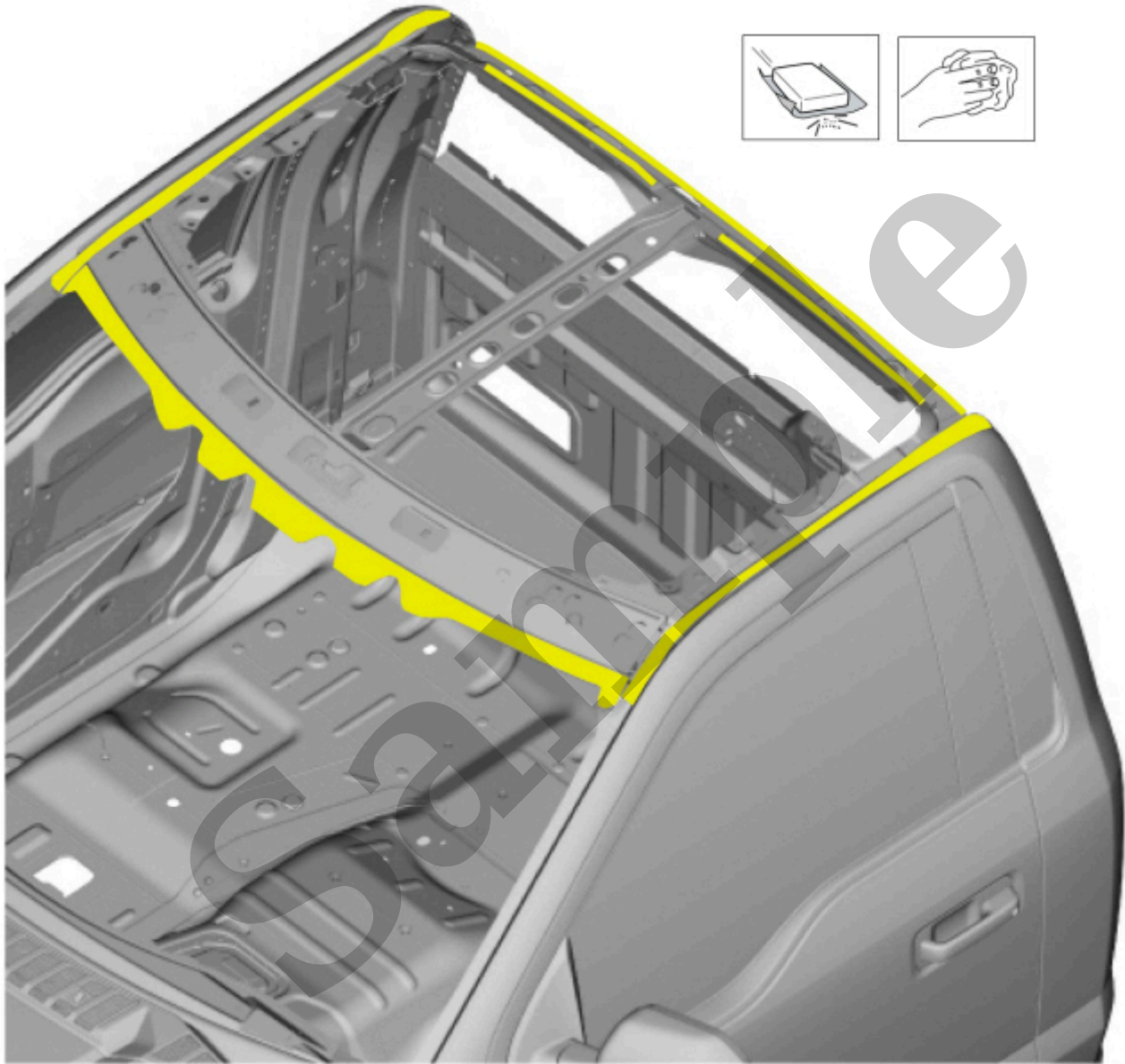

E191303

[Click here to learn about symbols, color coding, and icons used in this manual.](#)

3. Sand to remove the e-coat and clean the roof panel mating surface using 80 grit sandpaper.

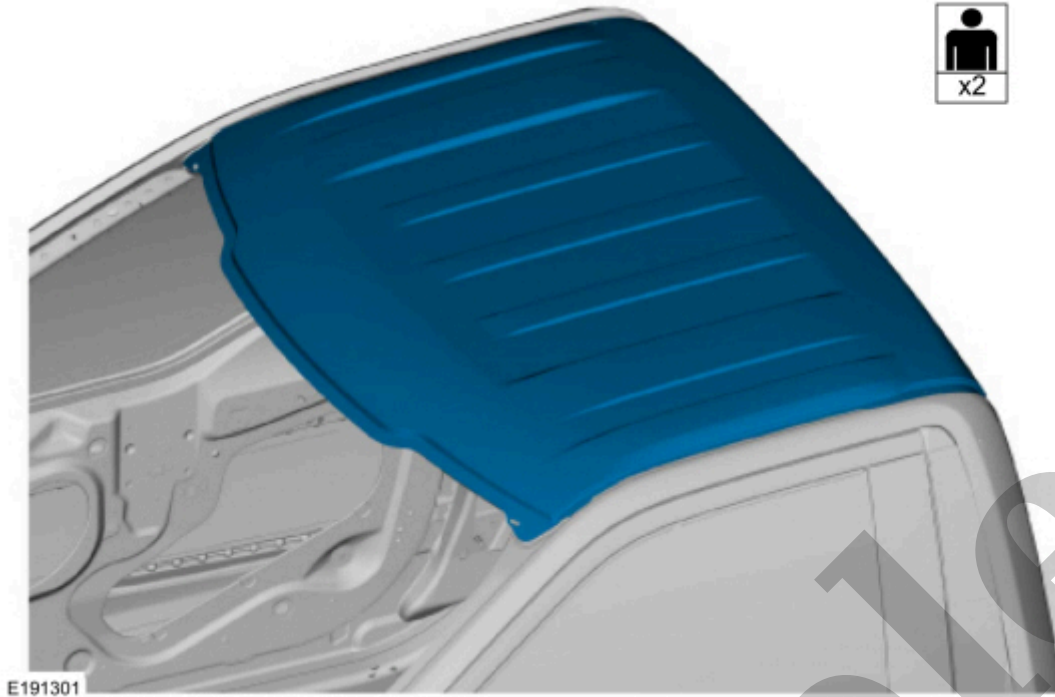

E191301

[Click here to learn about symbols, color coding, and icons used in this manual.](#)

5. Properly align and index mark the roof panel to the vehicle.

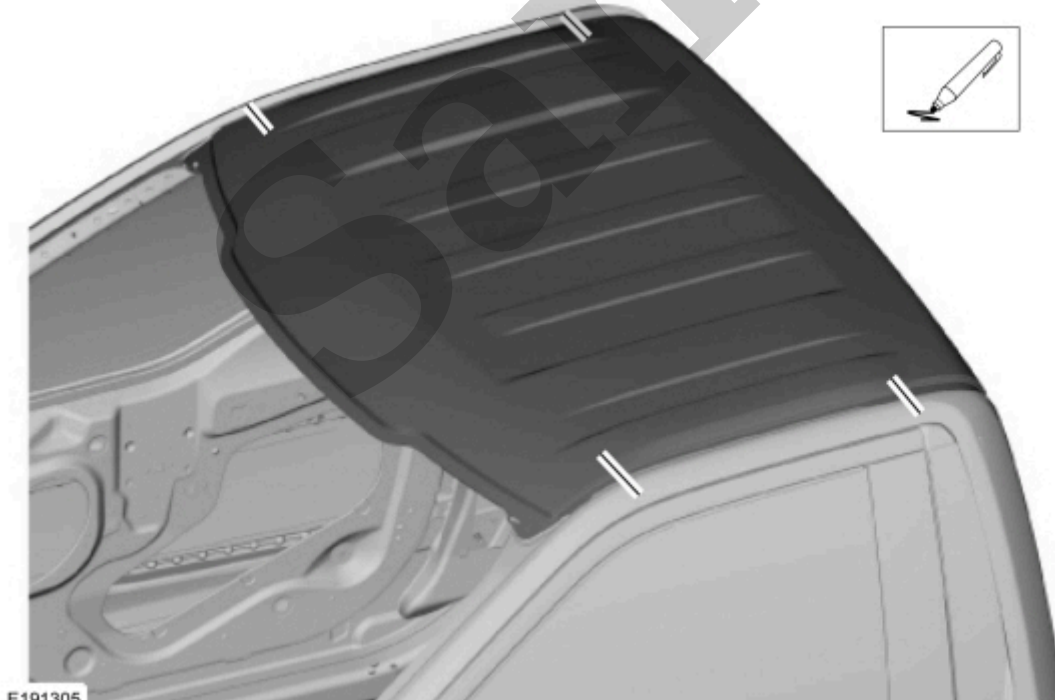

E191305

[Click here to learn about symbols, color coding, and icons used in this manual.](#)

6. With the help of an assistant, install the roof outer panel.