

# Your Ultimate Source for OEM Repair Manuals

FactoryManuals.net is a great resource for anyone who wants to save money on repairs by doing their own work. The manuals provide detailed instructions and diagrams that make it easy to understand how to fix a vehicle.

## 2000 VOLVO S70 OEM Service and Repair Workshop Manual

[Go to manual page](#)

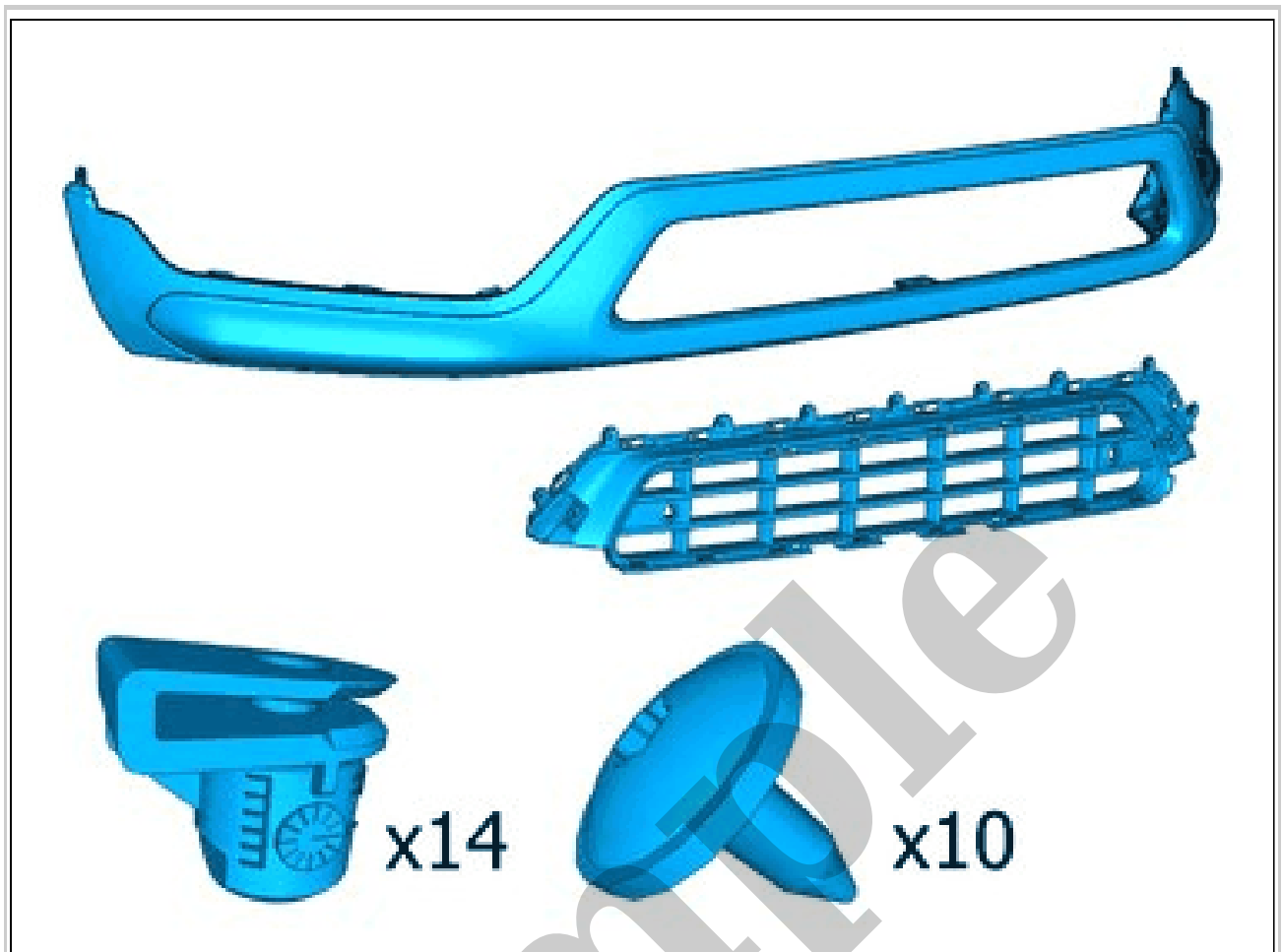

Courtesy of VOLVO CARS CORPORATION

## INFORMATION

- Read through all of the instructions before starting installation.
- Notifications and warning texts are for your safety and to minimize the risk of something breaking during installation.
- Ensure that all tools stated in the instructions are available before starting installation.
- Certain steps in the instructions are only presented in the form of images. Explanatory text is also given for more complicated steps.
- In the event of any problems with the instructions or the accessory, contact your local Volvo dealer.

## COLOR SYMBOLS

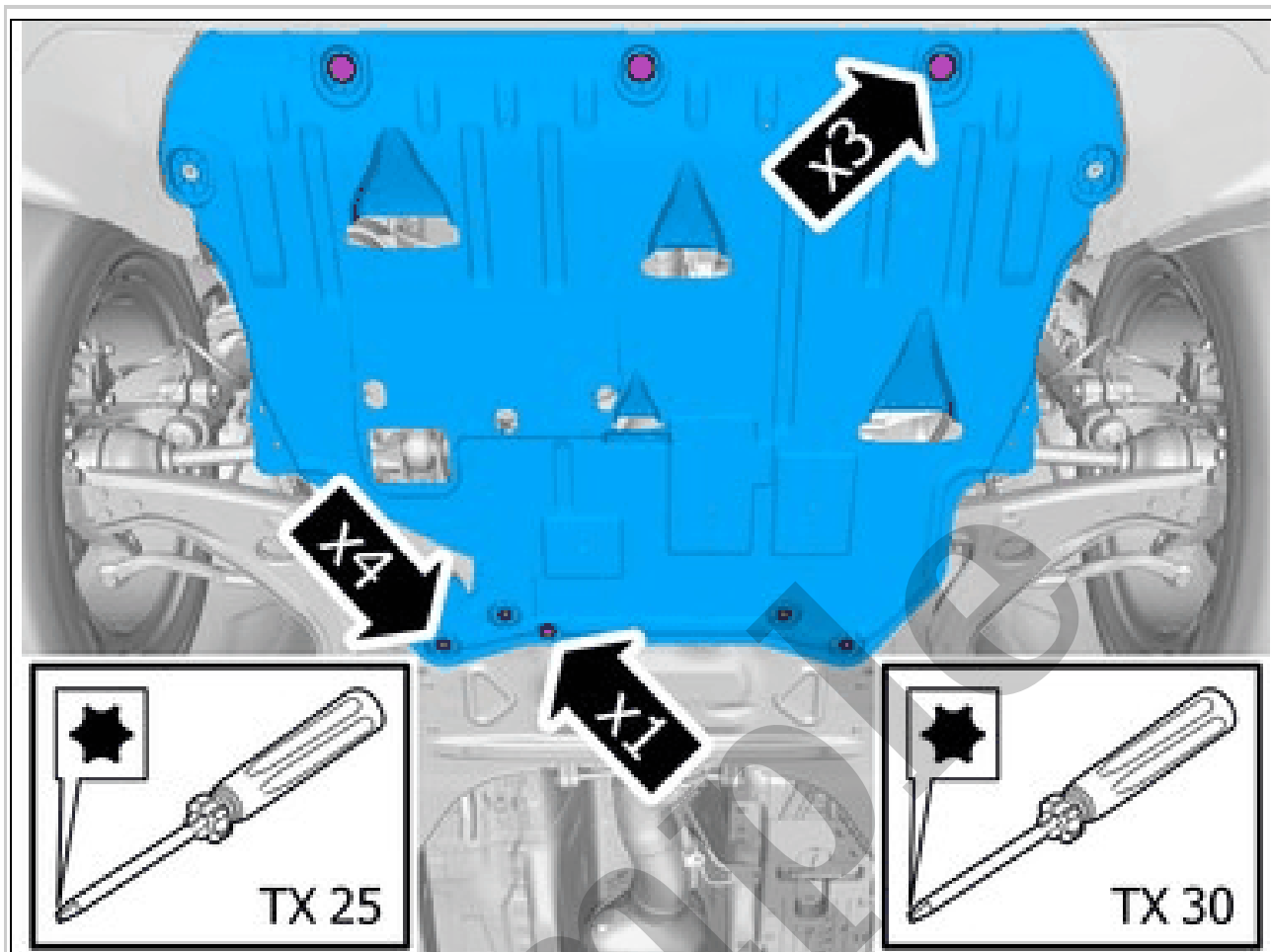

Courtesy of VOLVO CARS CORPORATION

- Remove the screws.
- Remove the clip.
- Remove the marked part.

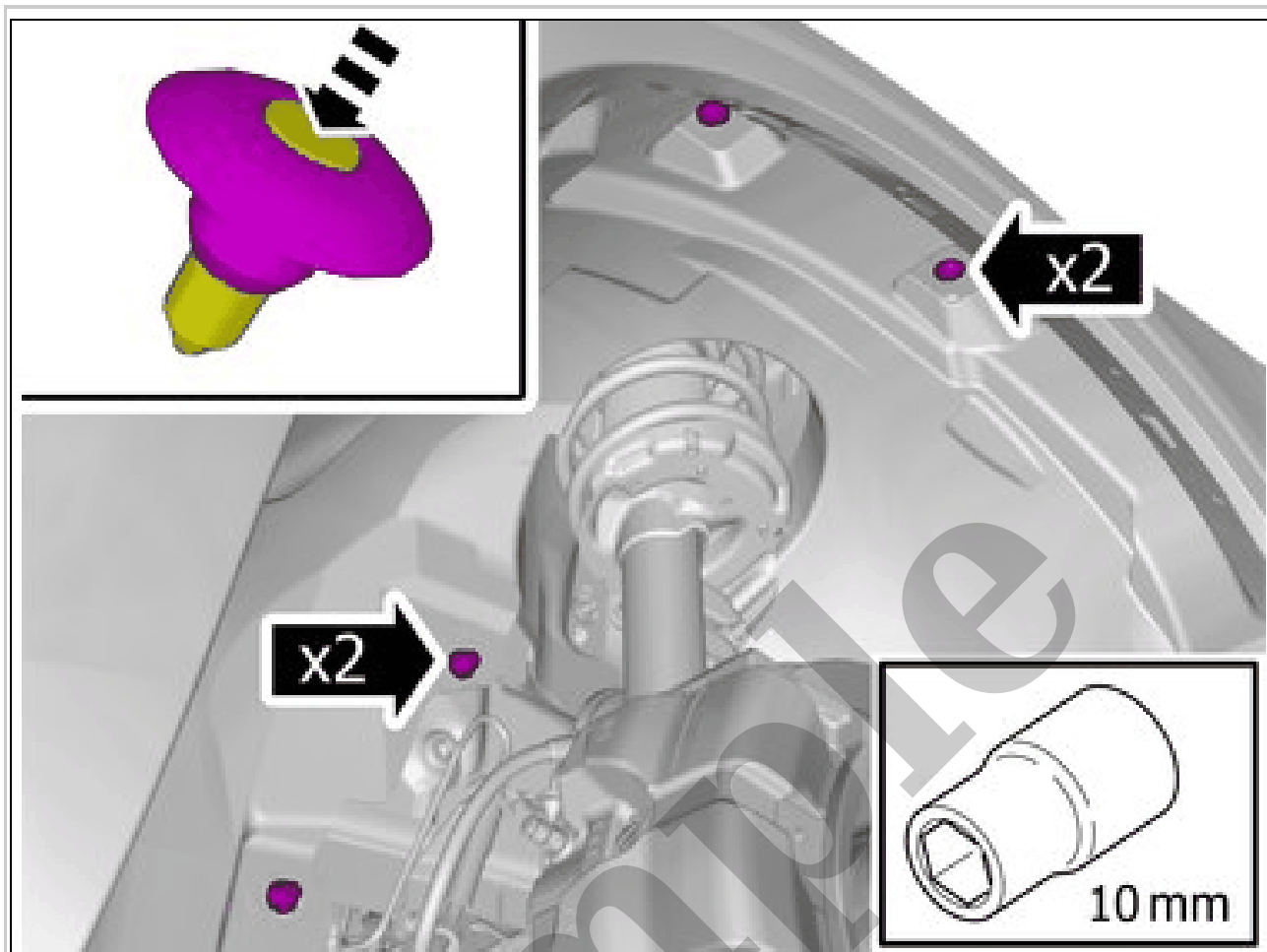

Courtesy of VOLVO CARS CORPORATION

Remove the nuts.  
Remove the clips.

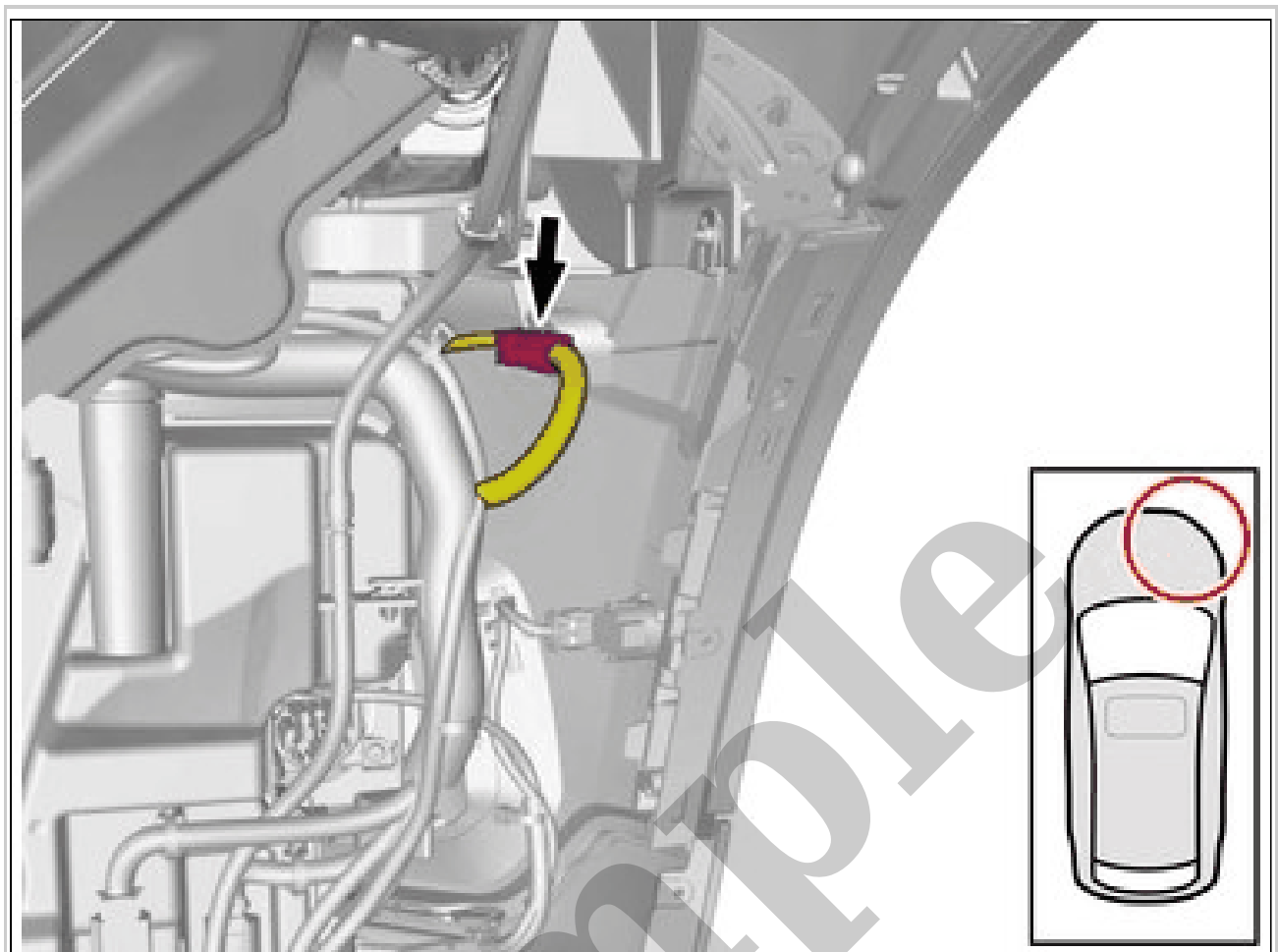

Courtesy of VOLVO CARS CORPORATION

**NOTE:** *The number of connectors may vary depending on the vehicle's equipment level.*

Disconnect the connector.

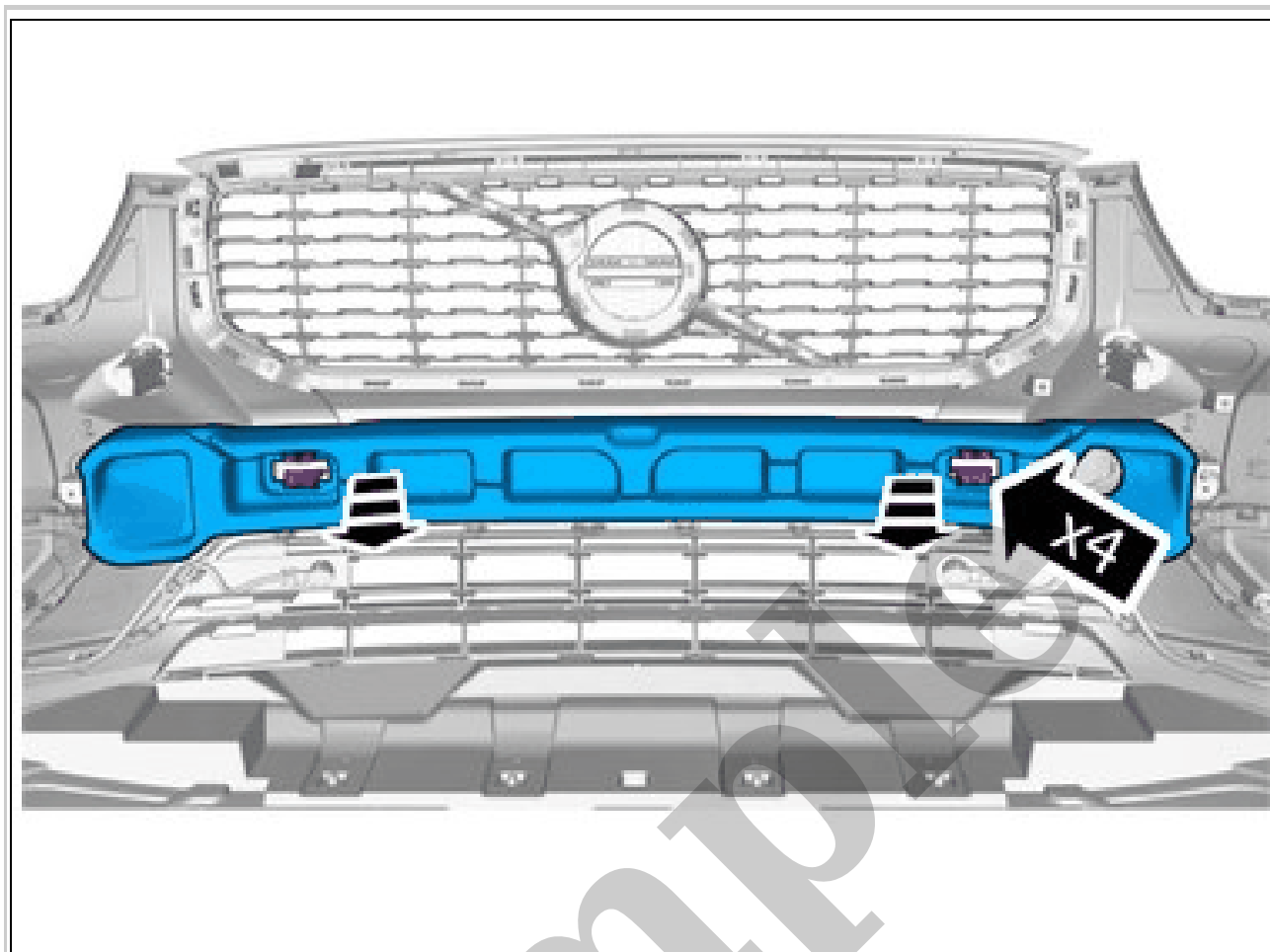

Courtesy of VOLVO CARS CORPORATION

Release the catches.  
Remove the marked part.

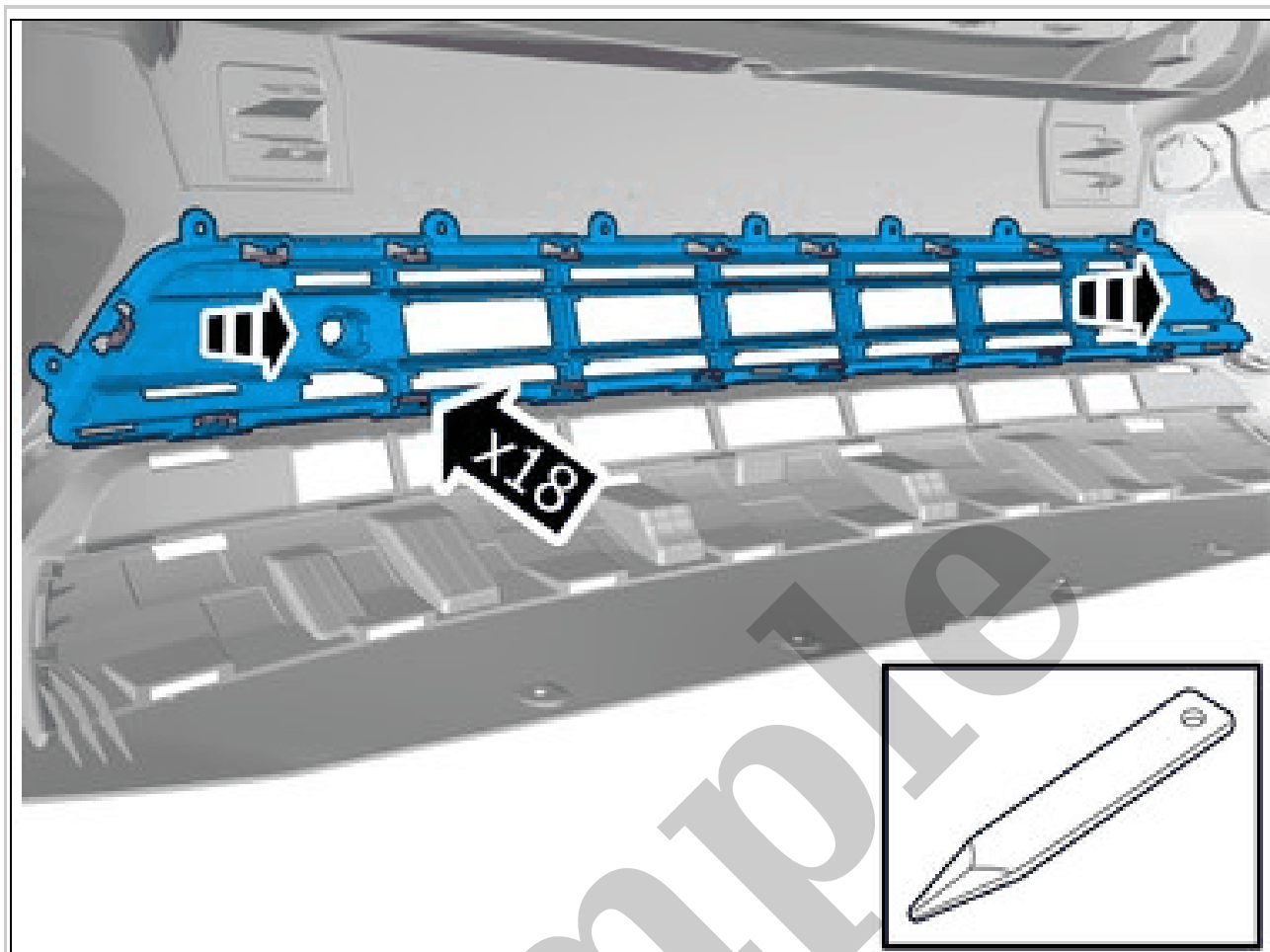

Courtesy of VOLVO CARS CORPORATION

Release the catches.  
Remove the marked part.

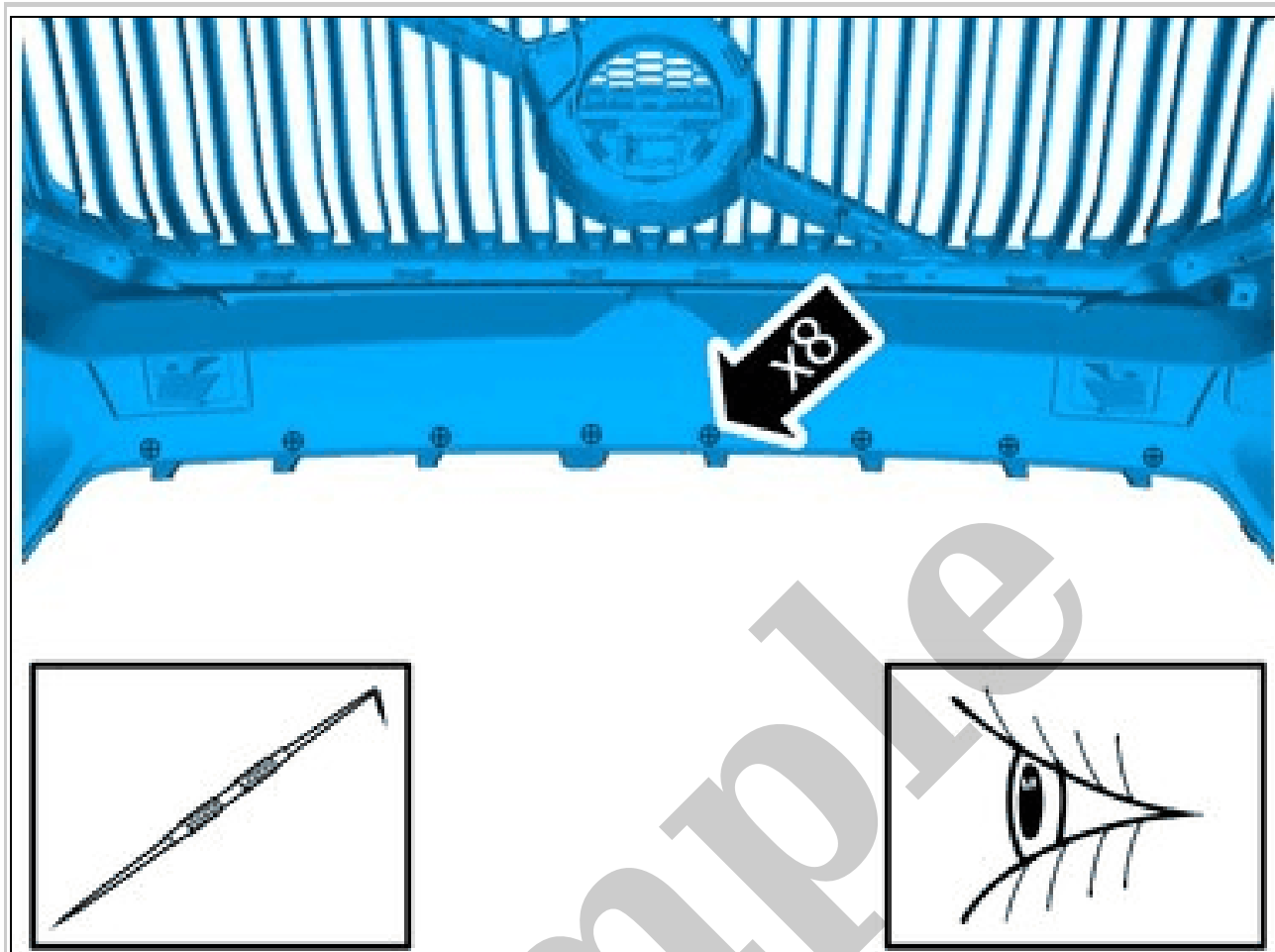

Courtesy of VOLVO CARS CORPORATION

Locate relevant marking.  
Mark the center.



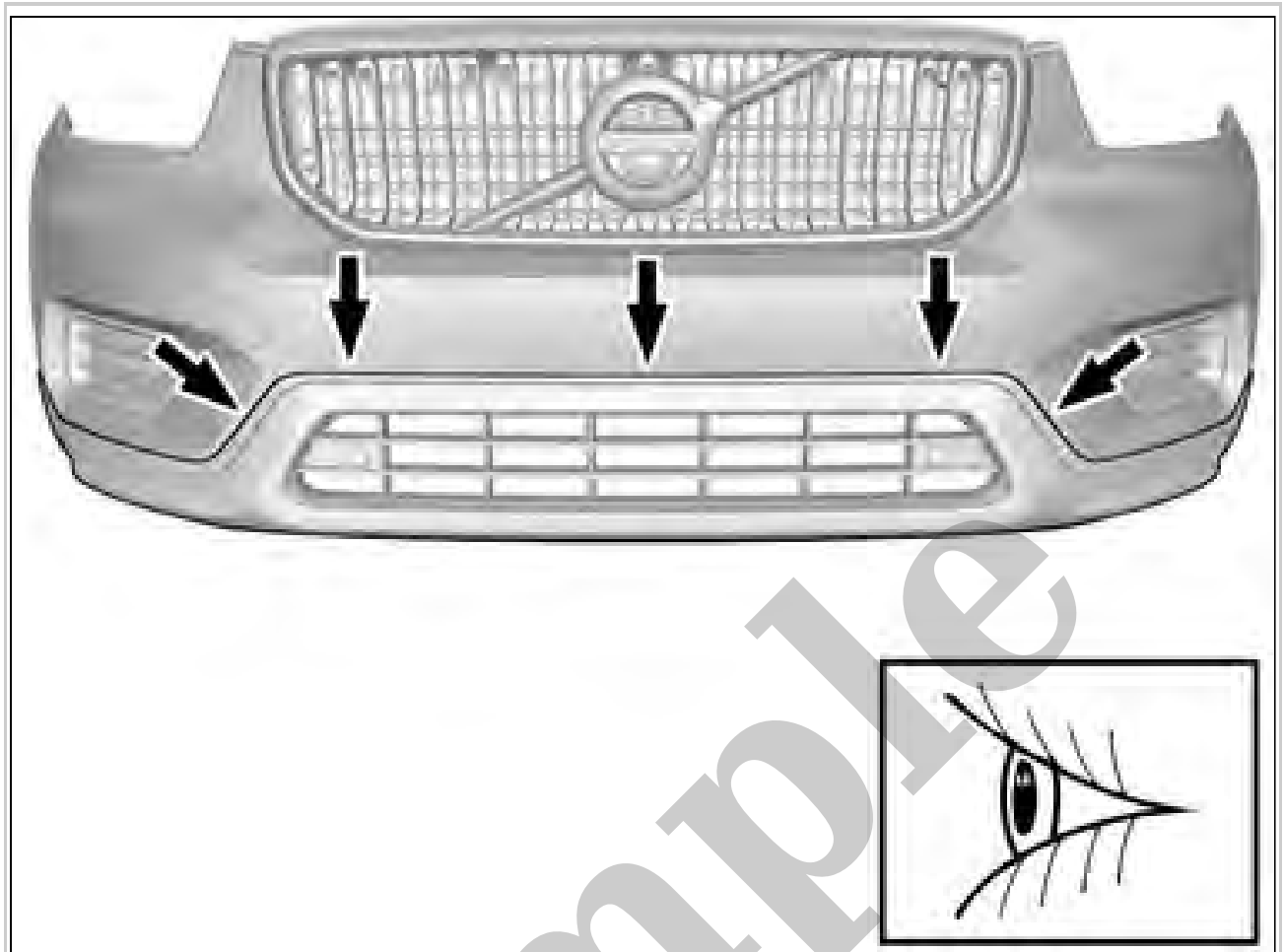

Courtesy of VOLVO CARS CORPORATION

**NOTE:** Adjust the position of the components to create even spaces.

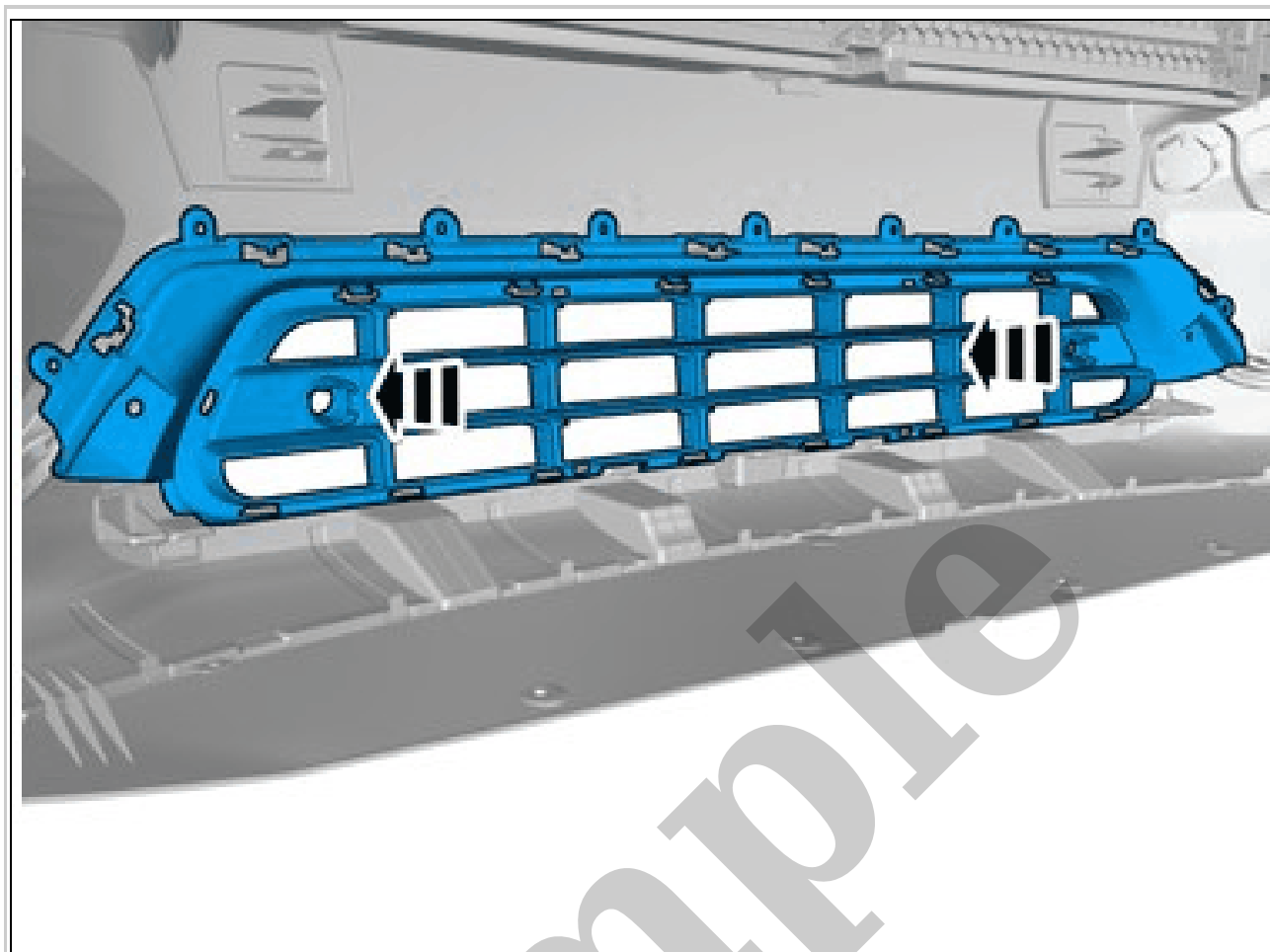

Courtesy of VOLVO CARS CORPORATION

Install component that comes with the accessory kit.