

Your Ultimate Source for OEM Repair Manuals

FactoryManuals.net is a great resource for anyone who wants to save money on repairs by doing their own work. The manuals provide detailed instructions and diagrams that make it easy to understand how to fix a vehicle.

1997 FORD Escort Cabrio OEM Service and Repair Workshop Manual

[Go to manual page](#)

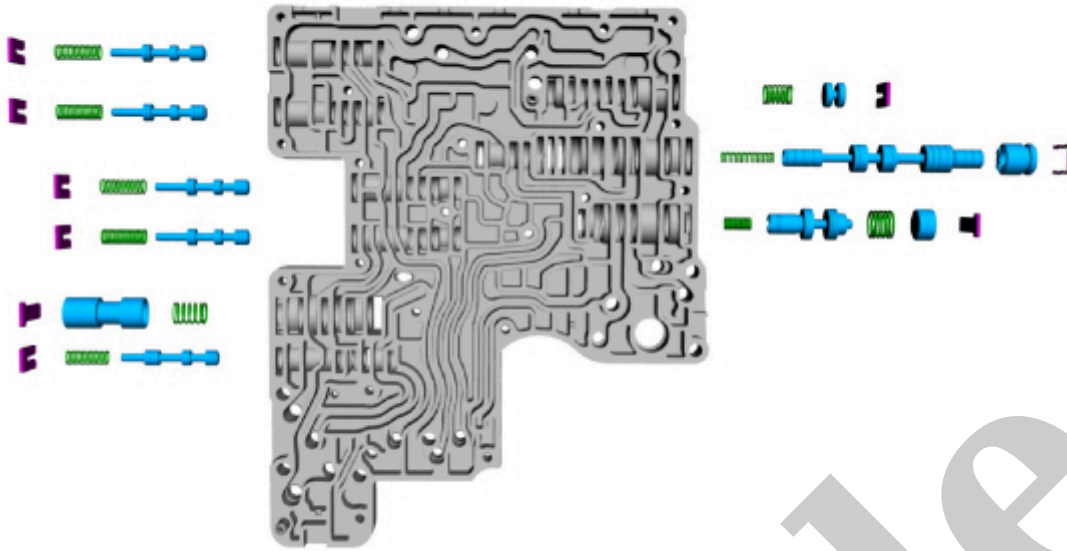

E330201

[Click here to learn about symbols, color coding, and icons used in this manual.](#)

Lower Valve Body

22. NOTICE

Failure to install the components in the correct location will result in harsh/soft or no shifts or damage to the transmission.

Install the valves, valve springs, cap and the retaining clips into the correct valve body valve bore.

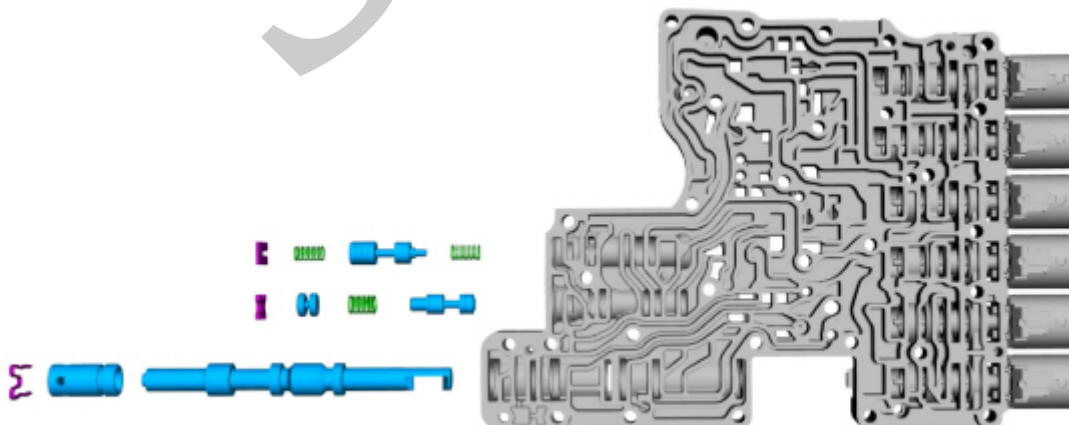

E261896

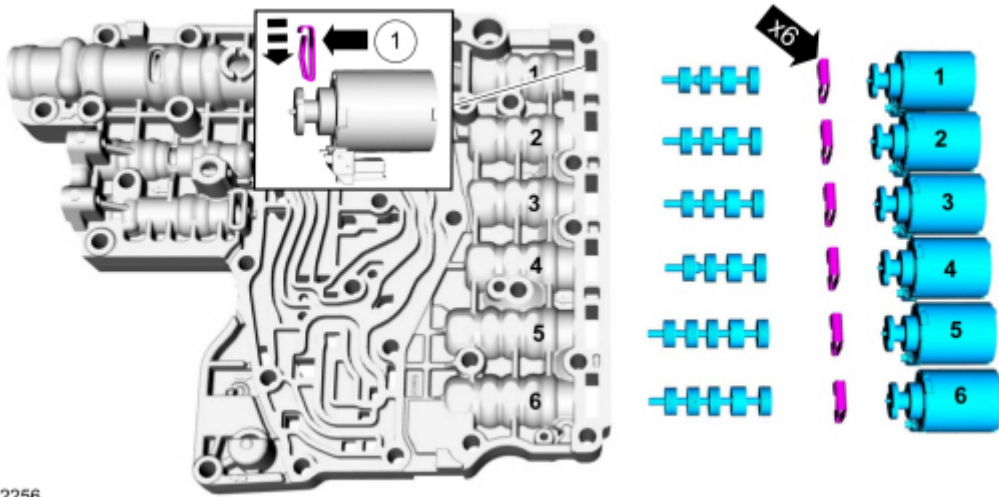

E242256

[Click here to learn about symbols, color coding, and icons used in this manual.](#)

25. Install the check balls.

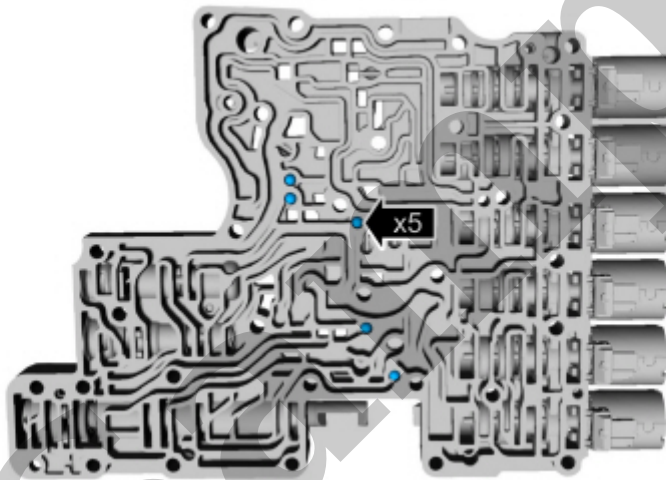

E261895

[Click here to learn about symbols, color coding, and icons used in this manual.](#)

26. **NOTE**

The orientation of the valves and springs.

Install the following items:

1. LPC (line pressure control) damper assembly
2. Clutch exhaust check valve
3. Transmission fluid auxiliary pump check valve

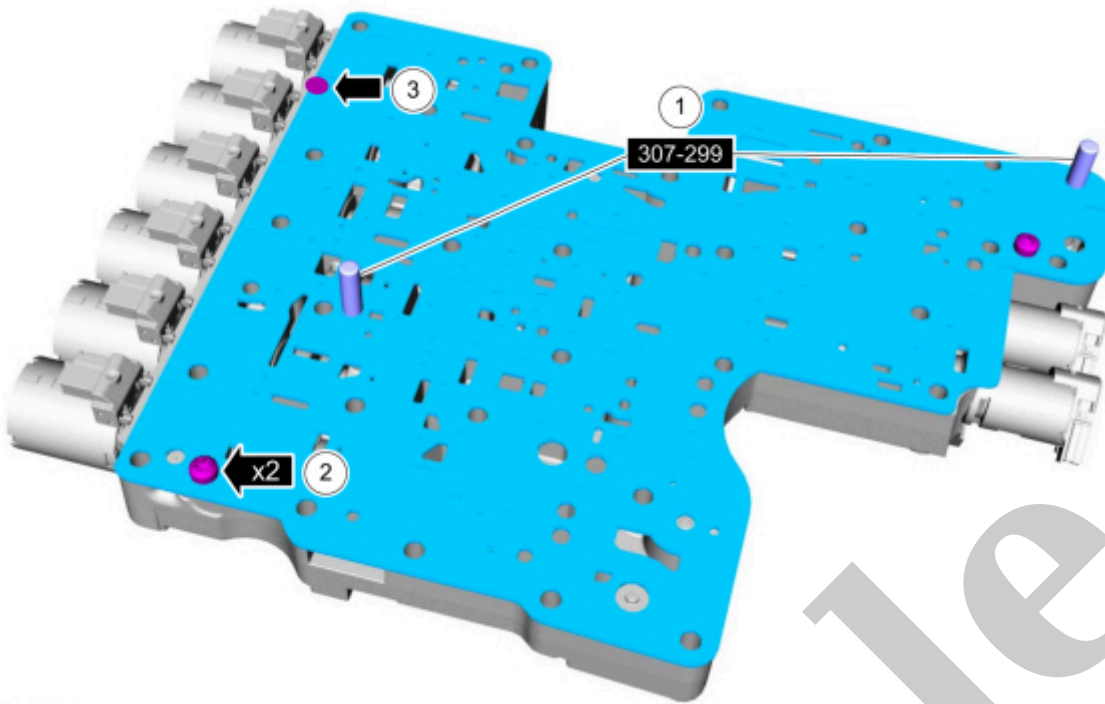

E262208

[Click here to learn about symbols, color coding, and icons used in this manual.](#)

Upper and Lower Valve Body

28. Align the guide pins on the upper valve body with the alignment holes in the lower valve body.

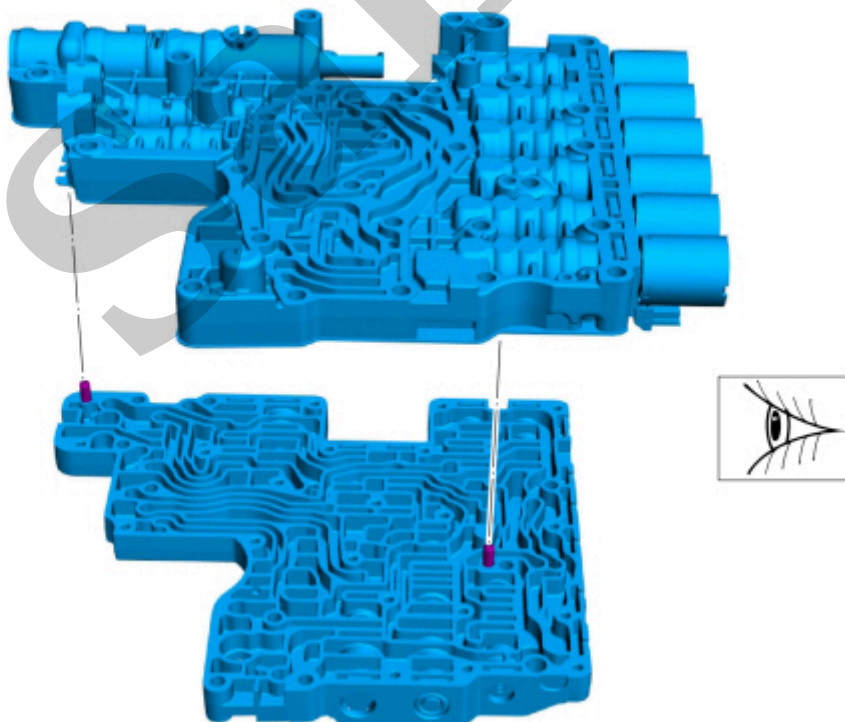

E261898

[Click here to learn about symbols, color coding, and icons used in this manual.](#)

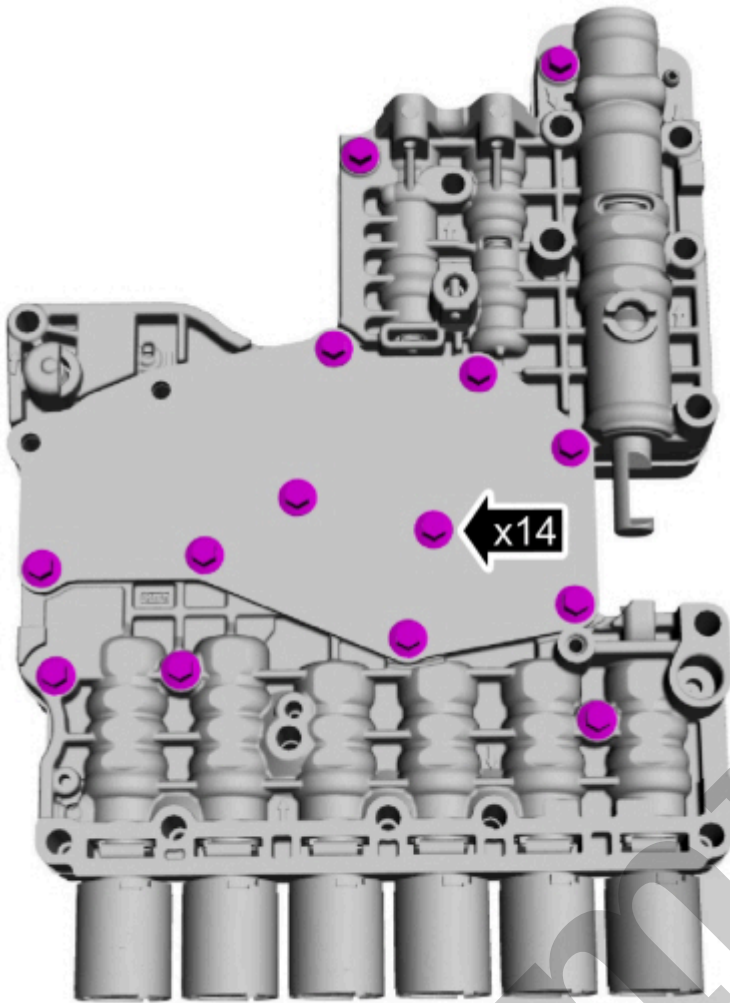

E261758

[Click here to learn about symbols, color coding, and icons used in this manual.](#)

31.
 1. Install the park lock pawl solenoid and loosely install the bolts.
 2. Install the shift solenoid retaining plate and loosely install the bolts.

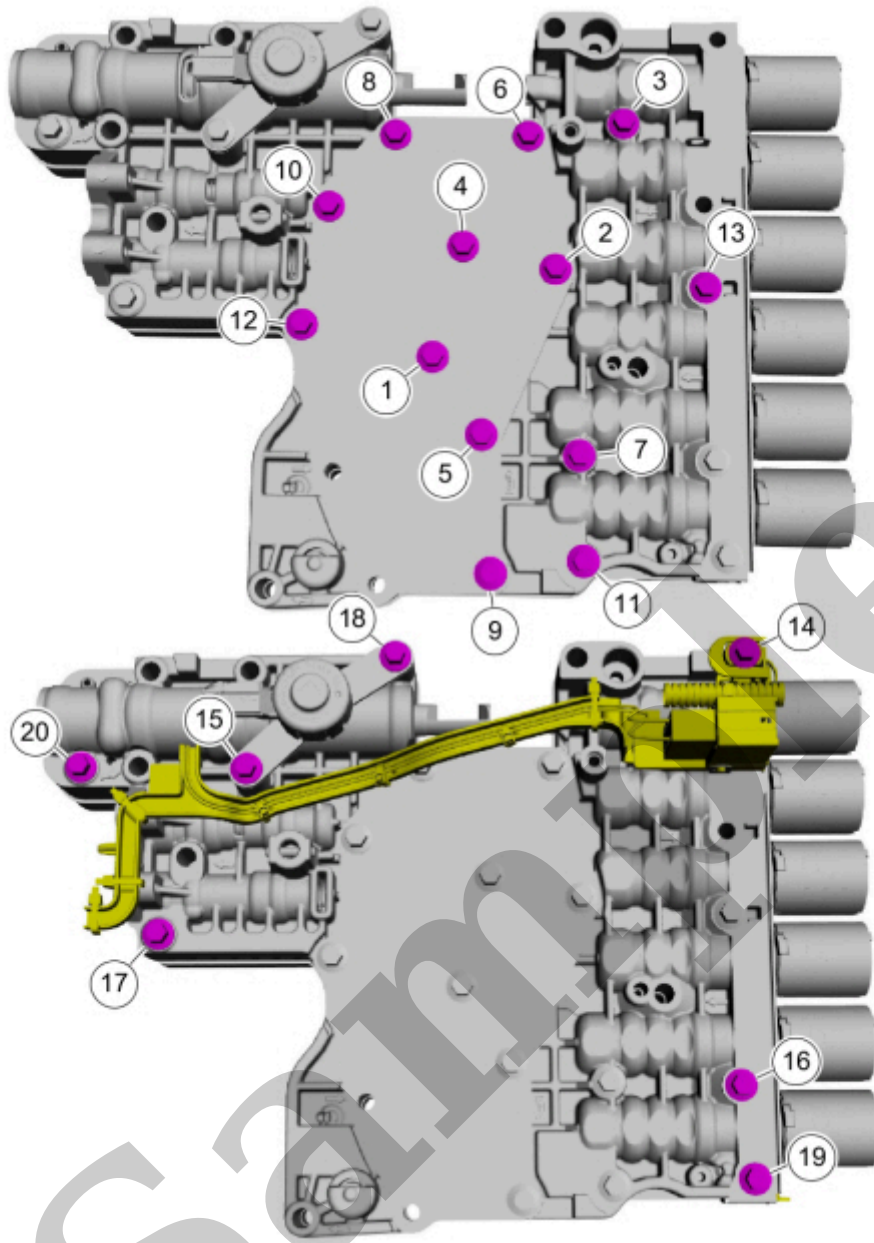

E262421

[Click here to learn about symbols, color coding, and icons used in this manual.](#)

33. Push the internal wiring harness into the retainer.

- Slide the plastic lock to the locked position.

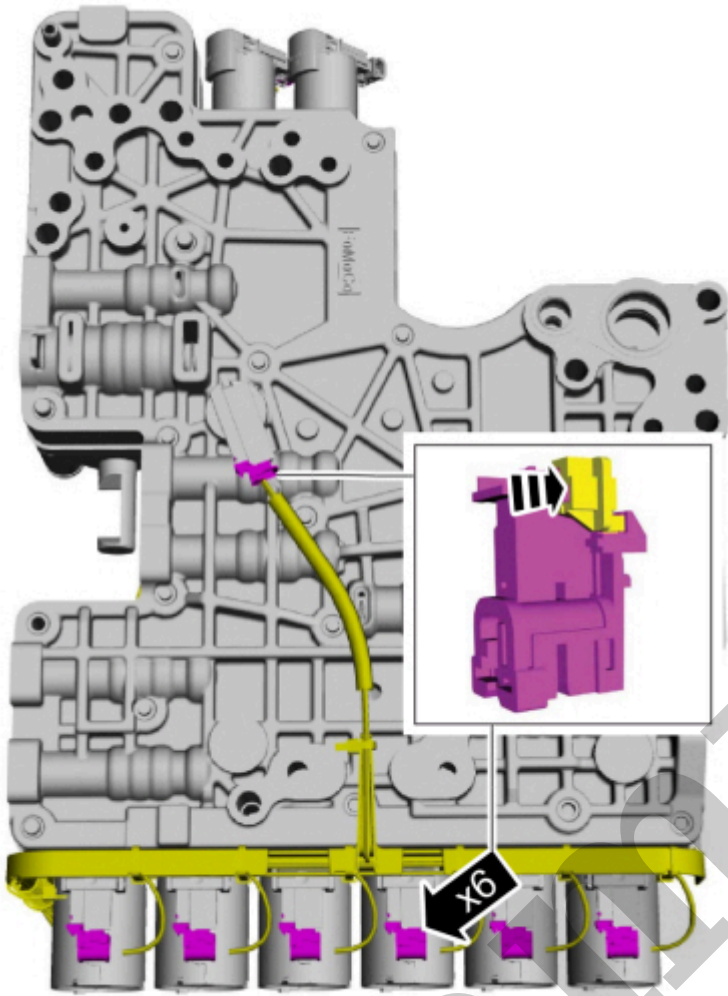

E262210

[Click here to learn about symbols, color coding, and icons used in this manual.](#)

36. NOTICE

Solenoids are calibrated from the factory and are not all the same. To replace a solenoid, match the replacement solenoid type (normally high/normally low) and the band number with the original solenoid or harsh shifts or damage to the transmission can occur.

If new solenoids are needed, identify which type (normally high/normally low) of solenoid it is and the solenoid band number.

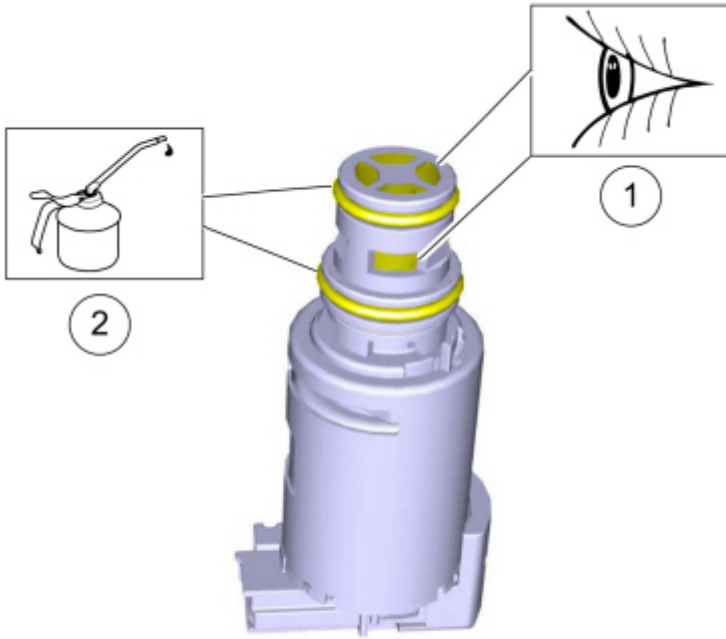

E242988

[Click here to learn about symbols, color coding, and icons used in this manual.](#)

38. Install the TCC (torque converter clutch) solenoid, LPC (line pressure control) solenoid, solenoid retaining plate and the new bolts.

Torque : 80 lb.in (9 Nm)

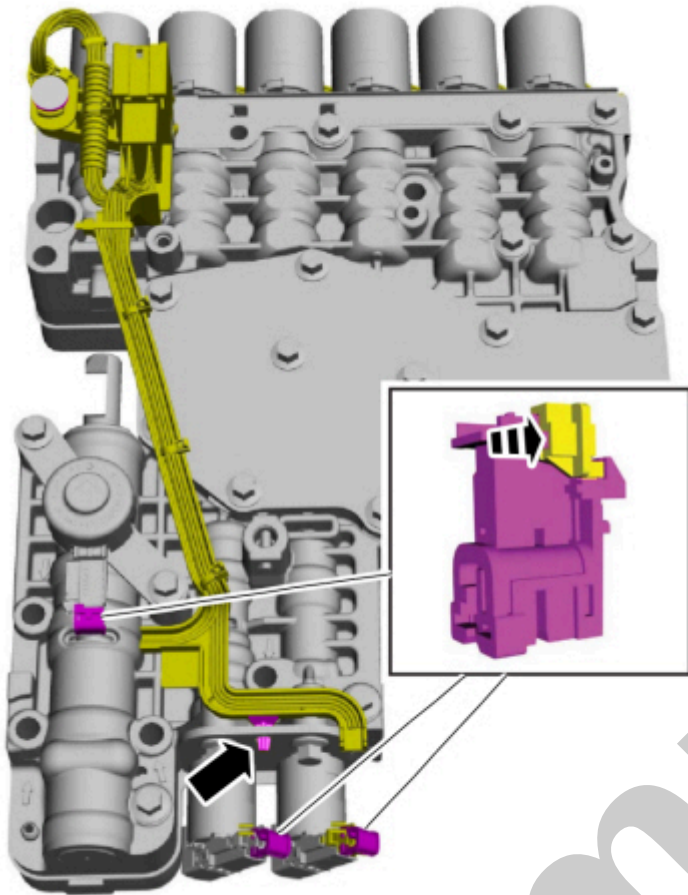

E261753

[Click here to learn about symbols, color coding, and icons used in this manual.](#)

40. Install the main control assembly to transmission fluid pump seal.

Transmission

307-01A Automatic Transmission - 10-Speed Automatic Transmission - 10R80	2022 F-150
Overhaul	Procedure revision date: 08/22/2022

Transmission

All vehicles

1. Transmission overhaul includes the following:

- Complete disassembly of the transmission
- Cleaning and inspecting of all components
- Replacement of all seals, gaskets, and one time use components. Use gasket kit -7153-
- Complete assembly with clearances adjusted to specification
- Replacement of any additional parts that may be required if worn or damaged

2. For information on component views and base part numbers.

Refer to: [Transmission Description](#)(307-01A Automatic Transmission - 10-Speed Automatic Transmission - 10R80, Description and Operation).

3. Using the special tool, install the transmission on a bench.

Use Special Service Tool : 307-003 (T57L-500-B) Holding Fixture, Transmission