

# Your Ultimate Source for OEM Repair Manuals

FactoryManuals.net is a great resource for anyone who wants to save money on repairs by doing their own work. The manuals provide detailed instructions and diagrams that make it easy to understand how to fix a vehicle.

## 1995 NISSAN Terrano II 3 Doors OEM Service and Repair Workshop Manual

[Go to manual page](#)

b While connector lock is pushed in , disconnect brake fluid level switch harness connector (B) in lateral direction (2) of vehicle.

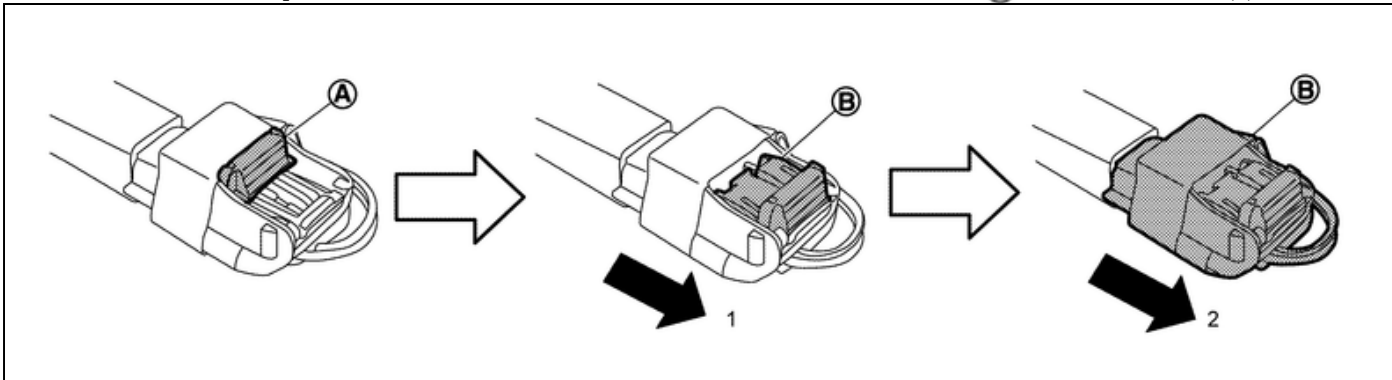

RPR-001824852-12-000347659

9 Disconnect electrically-driven intelligent brake unit harness connector (A) as follows;

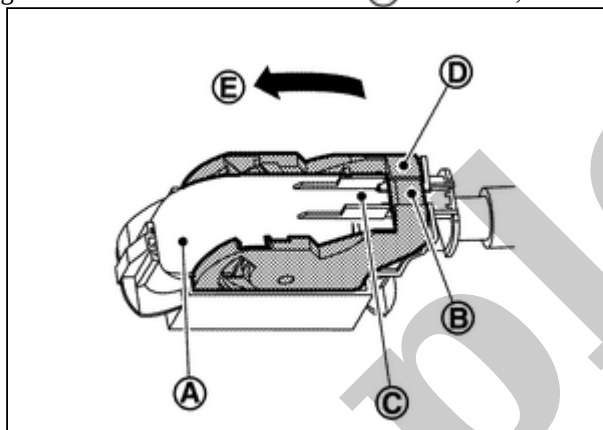

RPR-001824852-13-000347682

a Slide lever lock to right of vehicle and unlock it.

b While connector lock is pushed in, move lever to arrow (E) direction.

c Disconnect electrically-driven intelligent brake unit harness connector.

10 Disconnect stroke sensor harness connector as follows;

a Slide connector lock (A) to right (1) of vehicle.

b While connector lock (2) is pushed in , disconnect stroke sensor harness connector (B) in the front direction (3) of vehicle.

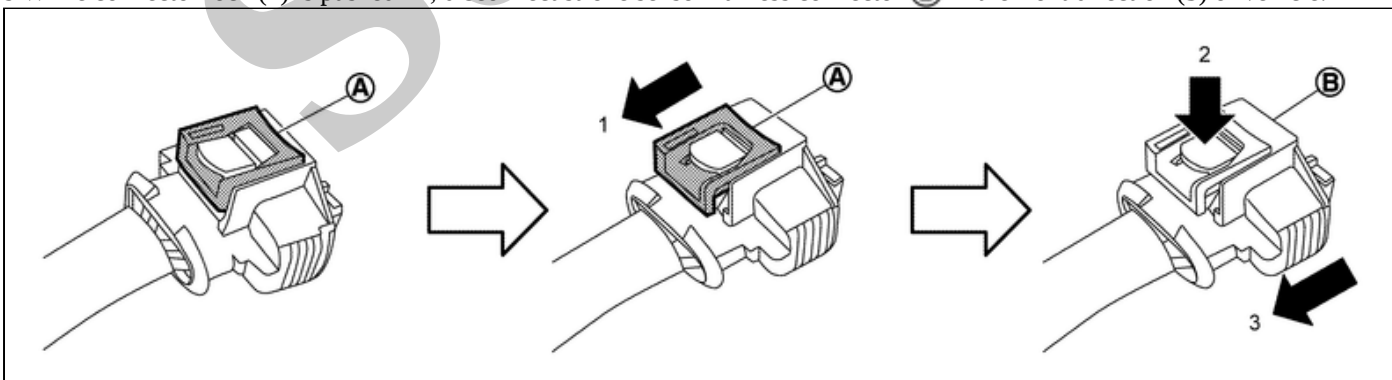

RPR-001824852-07-000347660

11 Remove stroke sensor harness clip (A) behind brake master cylinder (1).

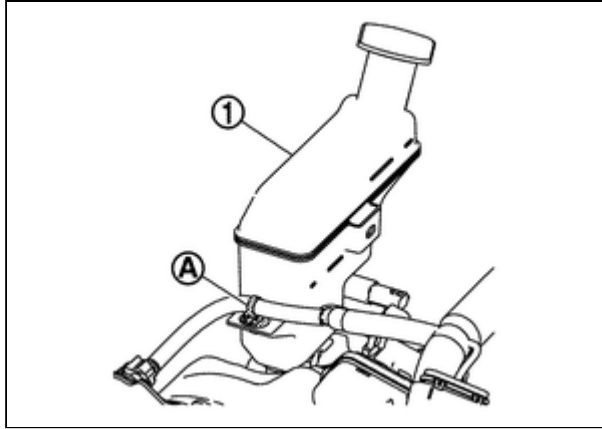

RPR-001824852-09-000347663

12 Remove snap pin and clevis pin from clevis.

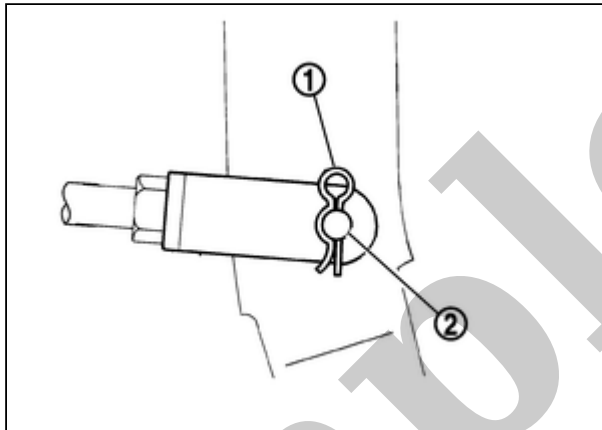

RPR-001824852-10-PFIA0019ZZ

13 Remove brake pedal bracket assembly. Refer to [Removal & Installation](#).

**CAUTION:**

**Hold electrically-driven intelligent brake unit to prevent it from dropping.**

14 Remove electrically-driven intelligent brake unit mounting nut.

15 Remove electrically-driven intelligent brake unit.

**CAUTION:**

**Never deform the brake tube when removing electrically-driven intelligent brake unit.**

16 Remove gasket from electrically-driven intelligent brake unit.

## INSTALLATION

**CAUTION:**

**When installing electrically-driven intelligent brake unit, never deform brake tube.**

- If electrically-driven intelligent brake unit is dropped or impacted, replace electrically-driven intelligent brake unit assembly.
- When installing, hold part **A** of electrically-driven intelligent brake unit.

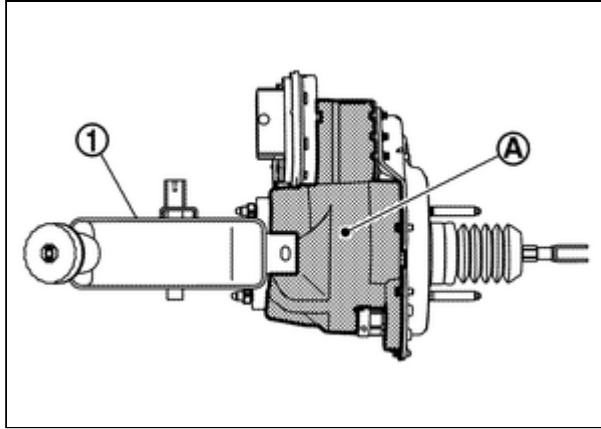

RPR-001824852-01-000354375

- Never apply grease or lubricant to the parts that contact with brake fluid and rubber parts.
- Never spill or splash brake fluid on painted surfaces. Brake fluid may seriously damage paint. Wipe it off immediately and wash with water if it gets on a painted surface. For brake component parts, never wash them with water.
- Never depress brake pedal during removal and installation of brake hose because brake fluid may scatter.

Note the following, and install in the reverse order of removal.

- Never crush threads of stud bolts of the electrically-driven intelligent brake unit. When installing diagonally, the dash panel may damage the threads.
- Never deform brake tube when installing electrically-driven intelligent brake unit.
- Never reuse clevis pin.
- Temporarily tighten flare nut of brake tube ① by hand, and then install it to the electrically-driven intelligent brake unit ② to the specified tightening torque using flare nut torque wrench (A). Refer to [Exploded View](#).

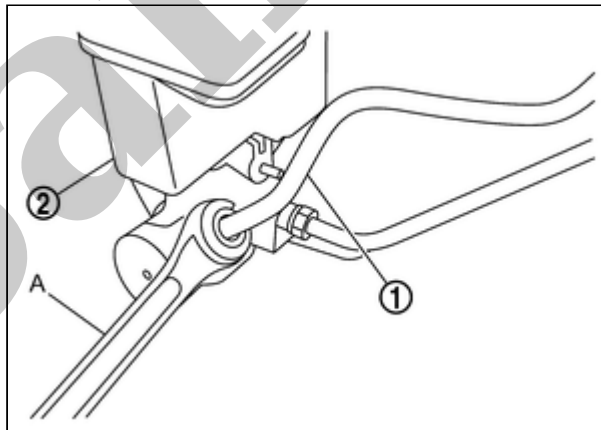

RPR-001824852-03-000279706

- After installing electrically-driven intelligent brake unit harness connector (A), move lever part (B) in the (C) direction until it locks, and push in lock part (D) to lock it securely.

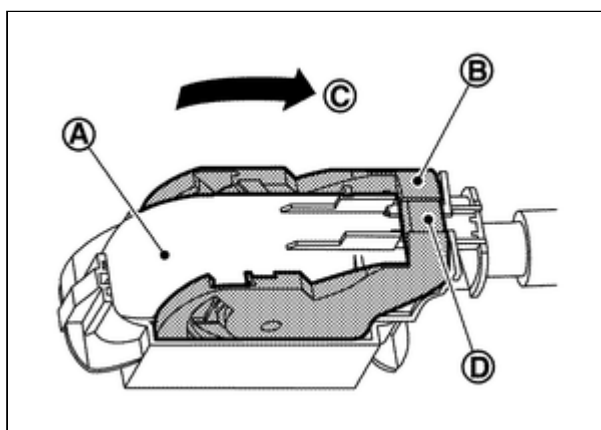

RPR-001824852-02-000347683

- Install stroke sensor harness connector as follows;

1. Insert connector lock (A) into electrically-driven intelligent brake unit (1).
2. Push in the connector lock (B) in the (2) direction and securely lock.

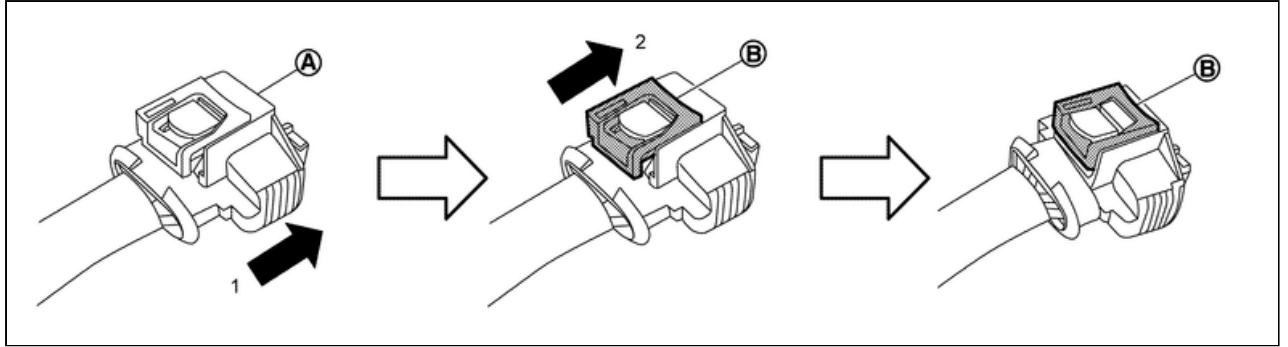

RPR-001824852-04-000353815

- Install brake fluid level switch harness connector as follows;

1. Insert connector (A) to brake fluid level switch.
2. Push in connector lock (B) in the (2) direction and securely lock.

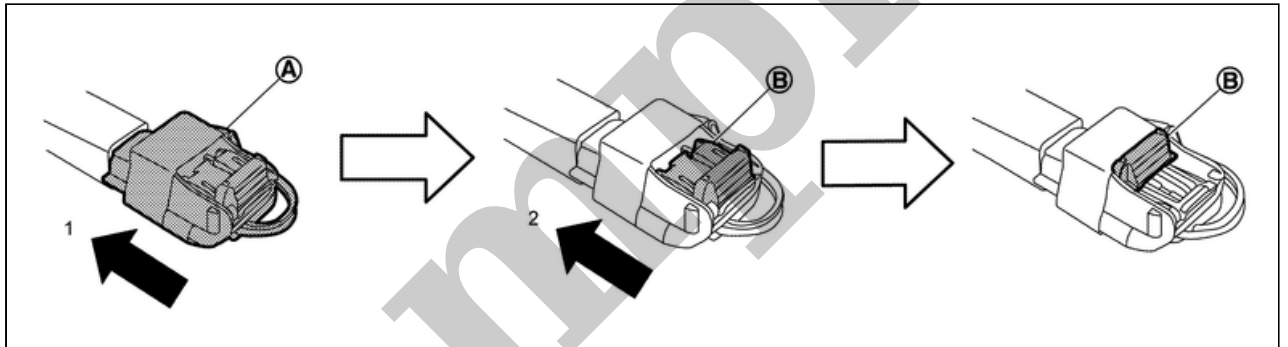

RPR-001824852-14-000353814

- Perform air bleeding. Refer to [Air Bleeding](#).
- Check brake pedal for each item, adjust when there is deviation from the specified value. Refer to [Periodic Maintenance Operation](#).

## INSPECTION BEFORE REMOVAL

---

Check brake fluid level switch. Refer to [DTC Diagnosis Procedure](#).

## INSPECTION AFTER REMOVAL

---

Check the following items, and replace the part if necessary.

- Check for damage, deformation, interference with the other parts, and looseness of connection.
- Check for fluid leakage from connection. Refer to [Inspection](#)

**CAUTION:**

**When fluid leakage is occurred, tighten each bolt to the specified torque. Replace parts if there is still leakage.**

## INSPECTION AFTER INSTALLATION

---

Must be performed additional service when replacing electrically-driven intelligent brake unit. Refer to [Description](#).

Sample

DTC	Display item	Brake warning lamp	Brake system warning lamp	Refer to
B14E0-02	Wheel sensor	OFF	ON	<a href="#">DTC Description</a>
B14E0-09	Wheel sensor	OFF	ON	<a href="#">DTC Description</a>
B14E0-11	Wheel sensor	OFF	ON	<a href="#">DTC Description</a>
B14E0-12	Wheel sensor	OFF	ON	<a href="#">DTC Description</a>
B14E0-13	Wheel sensor	OFF	ON	<a href="#">DTC Description</a>
B14E0-1C	Wheel sensor	OFF	ON	<a href="#">DTC Description</a>
B14E0-38	Wheel sensor	OFF	ON	<a href="#">DTC Description</a>
B14E0-4A	Wheel sensor	OFF	ON	<a href="#">DTC Description</a>
B14E0-64	Wheel sensor	OFF	ON	<a href="#">DTC Description</a>
B14E1-02	Wheel sensor	OFF	ON	<a href="#">DTC Description</a>
B14E1-09	Wheel sensor	OFF	ON	<a href="#">DTC Description</a>
B14E1-11	Wheel sensor	OFF	ON	<a href="#">DTC Description</a>
B14E1-12	Wheel sensor	OFF	ON	<a href="#">DTC Description</a>
B14E1-13	Wheel sensor	OFF	ON	<a href="#">DTC Description</a>
B14E1-1C	Wheel sensor	OFF	ON	<a href="#">DTC Description</a>
B14E1-38	Wheel sensor	OFF	ON	<a href="#">DTC Description</a>
B14E1-4A	Wheel sensor	OFF	ON	<a href="#">DTC Description</a>
B14E1-64	Wheel sensor	OFF	ON	<a href="#">DTC Description</a>
B14E2-02	Wheel sensor	OFF	ON	<a href="#">DTC Description</a>
B14E2-09	Wheel sensor	OFF	ON	<a href="#">DTC Description</a>
B14E2-11	Wheel sensor	OFF	ON	<a href="#">DTC Description</a>
B14E2-12	Wheel sensor	OFF	ON	<a href="#">DTC Description</a>
B14E2-13	Wheel sensor	OFF	ON	<a href="#">DTC Description</a>
B14E2-1C	Wheel sensor	OFF	ON	<a href="#">DTC Description</a>

DTC	Display item	Brake warning lamp	Brake system warning lamp	Refer to
B14E2-38	Wheel sensor	OFF	ON	<a href="#">DTC Description</a>
B14E2-4A	Wheel sensor	OFF	ON	<a href="#">DTC Description</a>
B14E2-64	Wheel sensor	OFF	ON	<a href="#">DTC Description</a>
B14E3-02	Wheel sensor	OFF	ON	<a href="#">DTC Description</a>
B14E3-09	Wheel sensor	OFF	ON	<a href="#">DTC Description</a>
B14E3-11	Wheel sensor	OFF	ON	<a href="#">DTC Description</a>
B14E3-12	Wheel sensor	OFF	ON	<a href="#">DTC Description</a>
B14E3-13	Wheel sensor	OFF	ON	<a href="#">DTC Description</a>
B14E3-1C	Wheel sensor	OFF	ON	<a href="#">DTC Description</a>
B14E3-38	Wheel sensor	OFF	ON	<a href="#">DTC Description</a>
B14E3-4A	Wheel sensor	OFF	ON	<a href="#">DTC Description</a>
B14E3-64	Wheel sensor	OFF	ON	<a href="#">DTC Description</a>
B14E4-64	Wheel sensor	OFF	ON	<a href="#">DTC Description</a>
B14E5-64	Brake control system	OFF	OFF	<a href="#">DTC Description</a>
B14E5-92	Brake control system	OFF	OFF	<a href="#">DTC Description</a>
B14E6-85	Brake control system	OFF	OFF	<a href="#">DTC Description</a>
B14E6-92	Brake control system	OFF	OFF	<a href="#">DTC Description</a>
C18D0-01	Backup power supply unit	OFF	ON	<a href="#">DTC Description</a>
C18D1-09	Backup power supply unit	OFF	ON	<a href="#">DTC Description</a>
C18D2-12	Backup power supply unit	OFF	ON	<a href="#">DTC Description</a>
C18D3-14	Backup power supply unit	OFF	ON	<a href="#">DTC Description</a>
C18D4-14	Backup power supply unit	OFF	ON	<a href="#">DTC Description</a>
C18D5-09	Backup power supply unit	OFF	ON	<a href="#">DTC Description</a>
C18D6-09	Backup power supply unit	OFF	ON	<a href="#">DTC Description</a>
C18D7-09	Backup power supply unit	OFF	ON	<a href="#">DTC Description</a>



DTC	Display item	Brake warning lamp	Brake system warning lamp	Refer to
C18D8-09	Backup power supply unit	OFF	ON	<a href="#">DTC Description</a>
C18D9-09	Backup power supply unit	OFF	ON	<a href="#">DTC Description</a>
C18DA-09	Backup power supply unit	OFF	ON	<a href="#">DTC Description</a>
C18DB-09	Backup power supply unit	OFF	ON	<a href="#">DTC Description</a>
C18DC-09	Backup power supply unit	OFF	ON	<a href="#">DTC Description</a>
C18DD-09	Backup power supply unit	OFF	ON	<a href="#">DTC Description</a>
C18DE-82	Backup power supply unit communication	OFF	ON	<a href="#">DTC Description</a>
C18DE-83	Backup power supply unit communication	OFF	ON	<a href="#">DTC Description</a>
C18DE-87	Backup power supply unit communication	OFF	ON	<a href="#">DTC Description</a>
C18E1-04	Motor	OFF	OFF	<a href="#">DTC Description</a>
C18E1-07	Motor	ON	ON	<a href="#">DTC Description</a>
C18E1-18	Motor	ON	ON	<a href="#">DTC Description</a>
C18E1-19	Motor	ON	ON	<a href="#">DTC Description</a>
C18E1-49	Motor	ON	ON	<a href="#">DTC Description</a>
C18E1-4B	Motor	ON	ON	<a href="#">DTC Description</a>
C18E3-86	VDC system	OFF	ON	<a href="#">DTC Description</a>
C18E4-88	CAN communication system	OFF	ON	<a href="#">DTC Description</a>
C18E5-88	CAN communication system	OFF	ON	<a href="#">DTC Description</a>
C18E6-49	CAN communication system	OFF	ON	<a href="#">DTC Description</a>
C18E7-13	Power supply system	OFF	ON	<a href="#">DTC Description</a>
C18E7-16	Power supply system	ON	ON	<a href="#">DTC Description</a>
C18E7-17	Power supply system	ON	ON	<a href="#">DTC Description</a>
C18E7-1C	Power supply system	OFF	ON*	<a href="#">DTC Description</a>
C18E9-01	Control module	ON	ON	<a href="#">DTC Description</a>
C18E9-04	Control module	ON	ON	<a href="#">DTC Description</a>

DTC	Display item	Brake warning lamp	Brake system warning lamp	Refer to
C18E9-44	Control module	ON	ON	<a href="#">DTC Description</a>
C18E9-45	Control module	ON	ON	<a href="#">DTC Description</a>
C18E9-46	Control module	ON	ON	<a href="#">DTC Description</a>
C18E9-47	Control module	ON	ON	<a href="#">DTC Description</a>
C18E9-48	Control module	ON	ON	<a href="#">DTC Description</a>
C18E9-49	Control module	ON	ON	<a href="#">DTC Description</a>
C18E9-96	Control module	ON	ON	<a href="#">DTC Description</a>
C18EA-01	VDC system	OFF	ON	<a href="#">DTC Description</a>
C18EB-01	Backup power supply unit	ON	ON	<a href="#">DTC Description</a>
C18EC-01	Stroke sensor	ON	ON	<a href="#">DTC Description</a>
C18EC-04	Stroke sensor	ON	ON	<a href="#">DTC Description</a>
C18EC-11	Stroke sensor	ON	ON	<a href="#">DTC Description</a>
C18EC-12	Stroke sensor	ON	ON	<a href="#">DTC Description</a>
C18EC-13	Stroke sensor	ON	ON	<a href="#">DTC Description</a>
C18EC-14	Stroke sensor	ON	ON	<a href="#">DTC Description</a>
C18EC-15	Stroke sensor	ON	ON	<a href="#">DTC Description</a>
C18EC-1F	Stroke sensor	ON	ON	<a href="#">DTC Description</a>
C18ED-04	Motor power supply	ON	ON	<a href="#">DTC Description</a>
C18EE-01	Stroke sensor	ON	ON	<a href="#">DTC Description</a>
C18EE-04	Stroke sensor	ON	ON	<a href="#">DTC Description</a>
C18EE-64	Stroke sensor	ON	ON	<a href="#">DTC Description</a>
C18EE-87	Stroke sensor	ON	ON	<a href="#">DTC Description</a>
C18EE-96	Stroke sensor	ON	ON	<a href="#">DTC Description</a>
C18EF-16	Rotor position sensor	ON	ON	<a href="#">DTC Description</a>
C18EF-17	Rotor position sensor	ON	ON	<a href="#">DTC Description</a>