

# Your Ultimate Source for OEM Repair Manuals

FactoryManuals.net is a great resource for anyone who wants to save money on repairs by doing their own work. The manuals provide detailed instructions and diagrams that make it easy to understand how to fix a vehicle.

## 1994 FORD Maverick LWB OEM Service and Repair Workshop Manual

[Go to manual page](#)

A scan tool that is capable of performing a self-test on the BECM (battery energy control module) is required. If the scan tool does not communicate with the BECM, refer to module communication network section 418-00.

- Using a scan tool perform BECM (battery energy control module) self test and record the Diagnostic Trouble Codes (DTCs).
- If BECM (battery energy control module) Diagnostic Trouble Codes (DTCs) P0563:00/P0AA1:00

**AND**

P0AA4:00 are present.

Refer to: [High Voltage Battery, Mounting and Cables - Electric](#)(414-03A High Voltage Battery, Mounting and Cables, Diagnosis and Testing).

12. **NOTICE**

Failure to turn the ignition off may result in component damage.

Turn the ignition OFF.

13. • Detach the retainers and remove the LH (left-hand) trim panel.

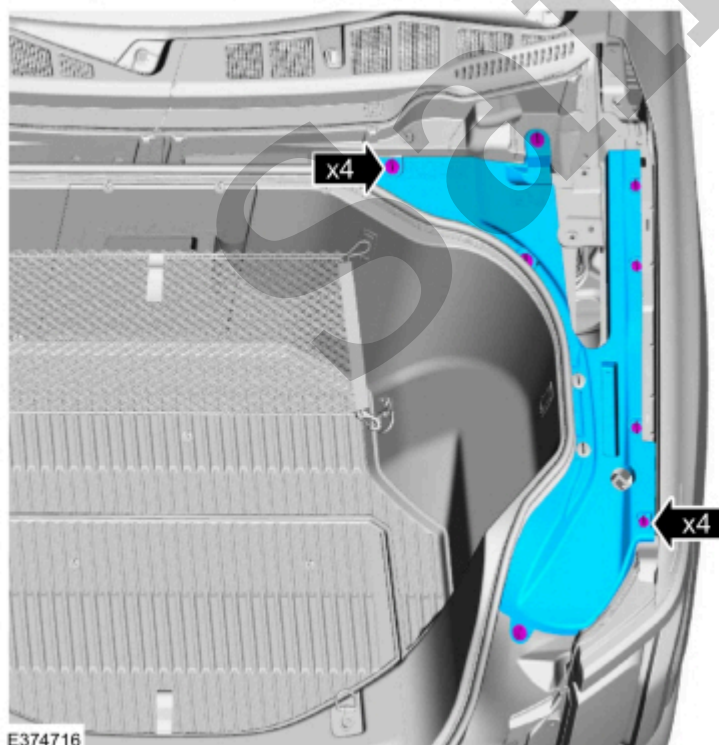

[Click here to learn about symbols, color coding, and icons used in this manual.](#)

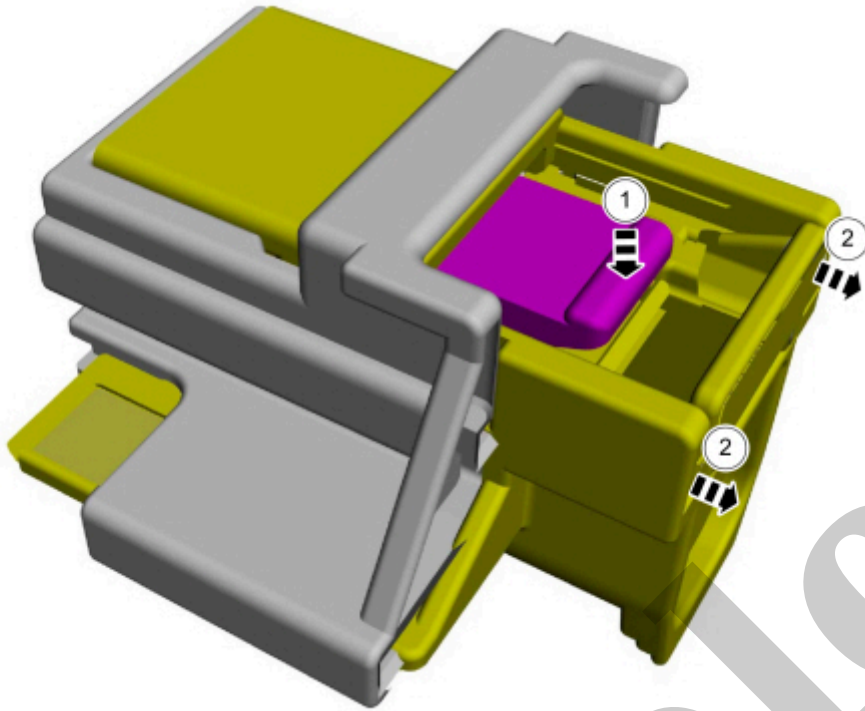

E316330

[Click here to learn about symbols, color coding, and icons used in this manual.](#)

16. **NOTE**

Make sure the electrical connector is secured with a cable tie when opened.

**NOTE**

The "Do not operate" Sign can be downloaded and printed out here: Sign „Do not operate“  
([https://www.fordservicecontent.com/ford\\_content/pdf/workshop/DoNotSwitch.pdf](https://www.fordservicecontent.com/ford_content/pdf/workshop/DoNotSwitch.pdf))

Install and secure the cable tie and the sign.

Install the General Equipment: Cable Ties

Video version of this procedure:

([https://www.fordservicecontent.com/Ford\\_Content/videos/WorkShopManual/V100.mp4](https://www.fordservicecontent.com/Ford_Content/videos/WorkShopManual/V100.mp4))

the vehicle again.

20. If disconnected, connect the high voltage electrical connectors to the High Voltage Battery.

21. If disconnected, connect the low voltage electrical connector to the High Voltage Battery.

22. Remove the cable tie and the sign.

Remove the General Equipment: Cable Ties

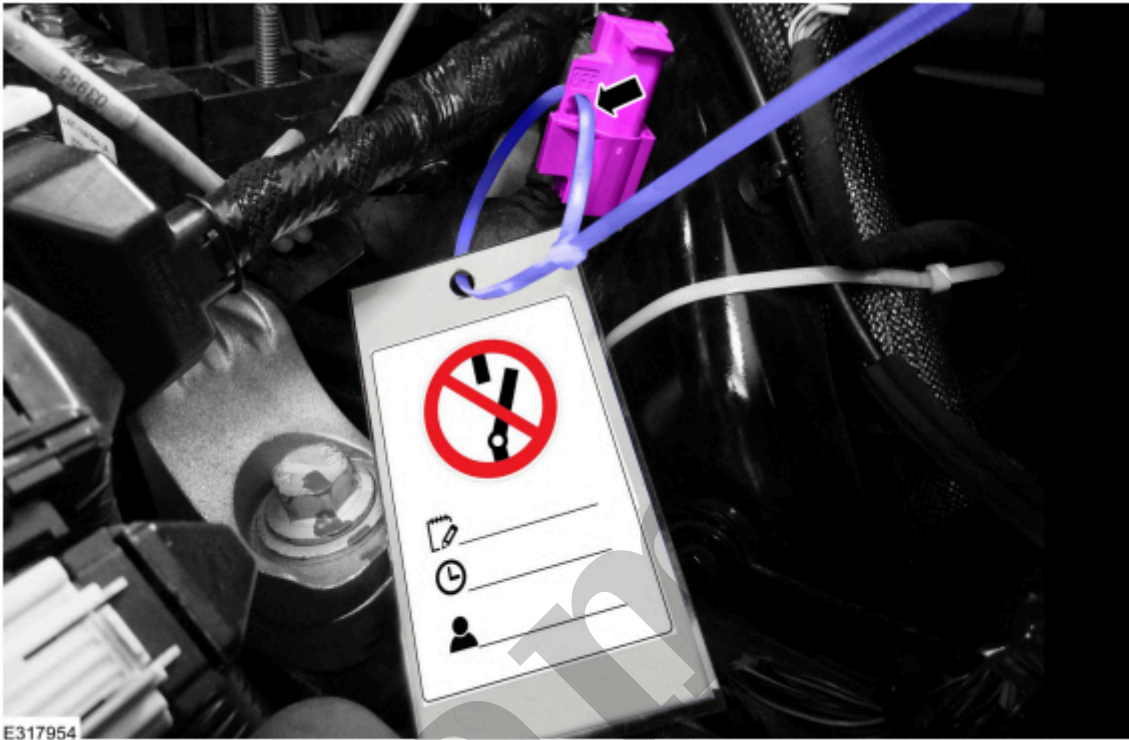

[Click here to learn about symbols, color coding, and icons used in this manual.](#)

23. **NOTE**

The tab must be depressed prior to pushing the connector back in or damage to the connector may result.

- Depress the tab while pushing the connector until the hole is not visible on the top of the connector.

25. • Install the LH (left-hand) trim panel and the fasteners.

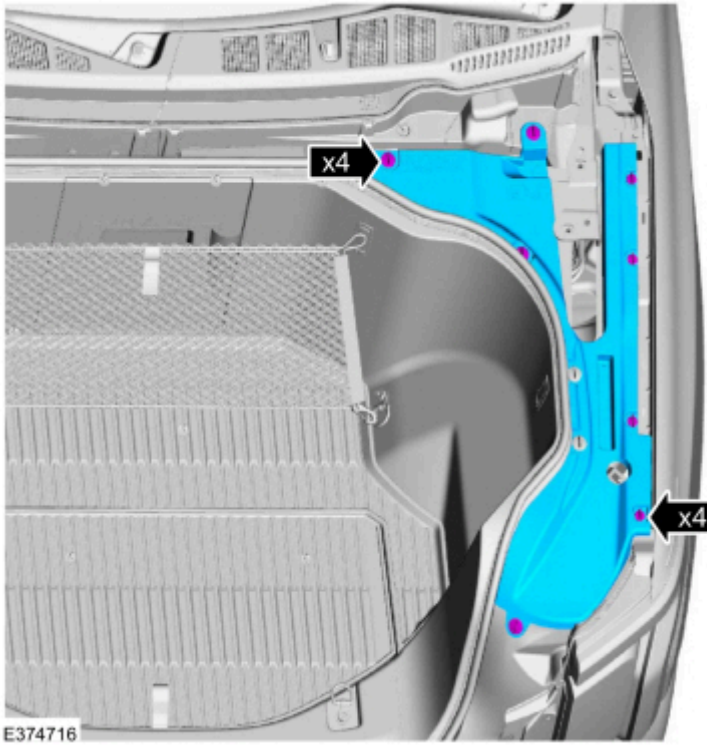

[Click here to learn about symbols, color coding, and icons used in this manual.](#)

Copyright © Ford Motor Company

Using the FDRS (Ford Diagnosis and Repair System) CARRY OUT the BECM (battery energy control module) -High Voltage System De-energizing and follow the on-screen instructions.

3. • Release the Connector Position Assurance (CPA) clip.

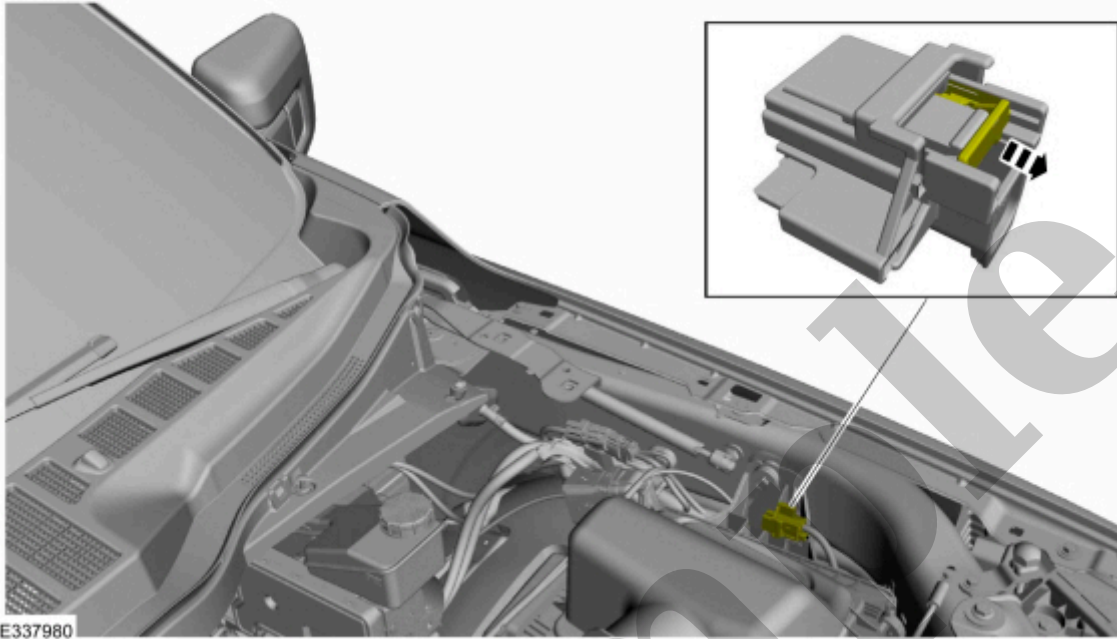

[Click here to learn about symbols, color coding, and icons used in this manual.](#)

4. • Depress the tab while pulling the connector until the hole is completely visible on the top of the connector.

- Using the FDRS (Ford Diagnosis and Repair System) COMPLETE the BECM (battery energy control module) -High Voltage System De-energizing and verify the high voltage system has been de-energized.

## Manual Depower

### WARNING

To prevent the risk of high-voltage shock, always follow precisely all warnings and service instructions, including instructions to depower the system. The high-voltage system utilizes approximately 450 volts DC, provided through high-voltage cables to its components and modules. The high-voltage cables and wiring are identified by orange harness tape or orange wire covering. All high-voltage components are marked with high-voltage warning labels with a high-voltage symbol. Failure to follow these instructions may result in serious personal injury or death.

### NOTICE

Manual De-energization should only be performed when a Ford – specific diagnostic tool is not available or the diagnostic tool procedure fails.

### NOTICE

Excessive use of this method may cause damage to electrical connectors.

### NOTICE

To prevent the risk of high voltage shock, the high voltage battery cover must not be removed if any of the following conditions exist: BECM (battery energy control module)DTC (diagnostic trouble code) P0AA6:00 that has been diagnosed to be an internal fault with the high voltage Battery. BECM (battery energy control module) Diagnostic Trouble Codes (DTCs) P0AA1:00 AND P0AA4:00 are present. BECM (battery energy control module) Diagnostic Trouble Codes (DTCs) P0D0F:00 AND P0AA4:00 are present ( PHEV (plug-in hybrid electric vehicle) only).

### 7. WARNING

Before beginning any service procedure in this manual, refer to health and safety warnings in section 100-00 General Information. Failure to follow this instruction may result in serious personal injury.

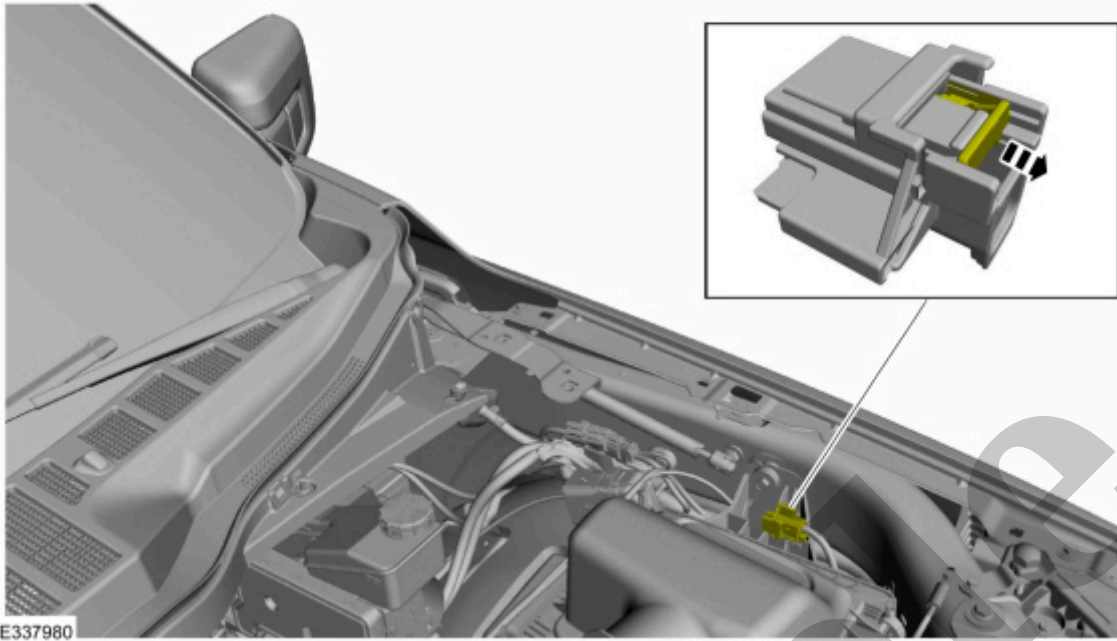

[Click here to learn about symbols, color coding, and icons used in this manual.](#)

13. • Depress the tab while pulling the connector until the hole is completely visible on the top of the connector.

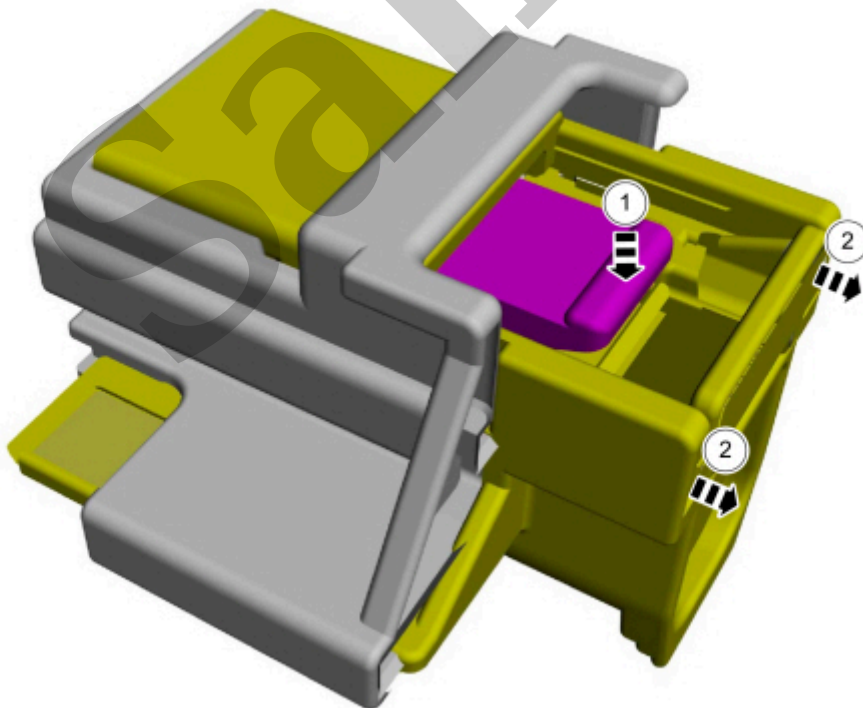

[Click here to learn about symbols, color coding, and icons used in this manual.](#)



In some cases the vehicle may be temporarily immobilized when attempting to start the vehicle after performing the repower procedure. If this occurs allow the vehicle to set for 5 minutes and attempt to start the vehicle again.

18.
  - Remove the suitable tool from the connector hole.



E318945

[Click here to learn about symbols, color coding, and icons used in this manual.](#)

19. **NOTE**

The tab must be depressed prior to pushing the connector back in or damage to the connector may result.

- Depress the tab while pushing the connector until the hole is not visible on the top of the connector.

21. If previously disconnected, connect the high voltage electrical connector to the high voltage battery.

22. If previously disconnected, connect the low voltage electrical connector to the high voltage battery.

Copyright © Ford Motor Company

Sample