

# Your Ultimate Source for OEM Repair Manuals

FactoryManuals.net is a great resource for anyone who wants to save money on repairs by doing their own work. The manuals provide detailed instructions and diagrams that make it easy to understand how to fix a vehicle.

## 1993 VOLVO 940 OEM Service and Repair Workshop Manual

[Go to manual page](#)

## CHARGE CONNECTOR > CHARGE CONNECTOR [2021-2022, E400V6] > REMOVAL AND INSTALLATION

### REMOVAL

Remove the high voltage battery. Refer to: HIGH VOLTAGE BATTERY

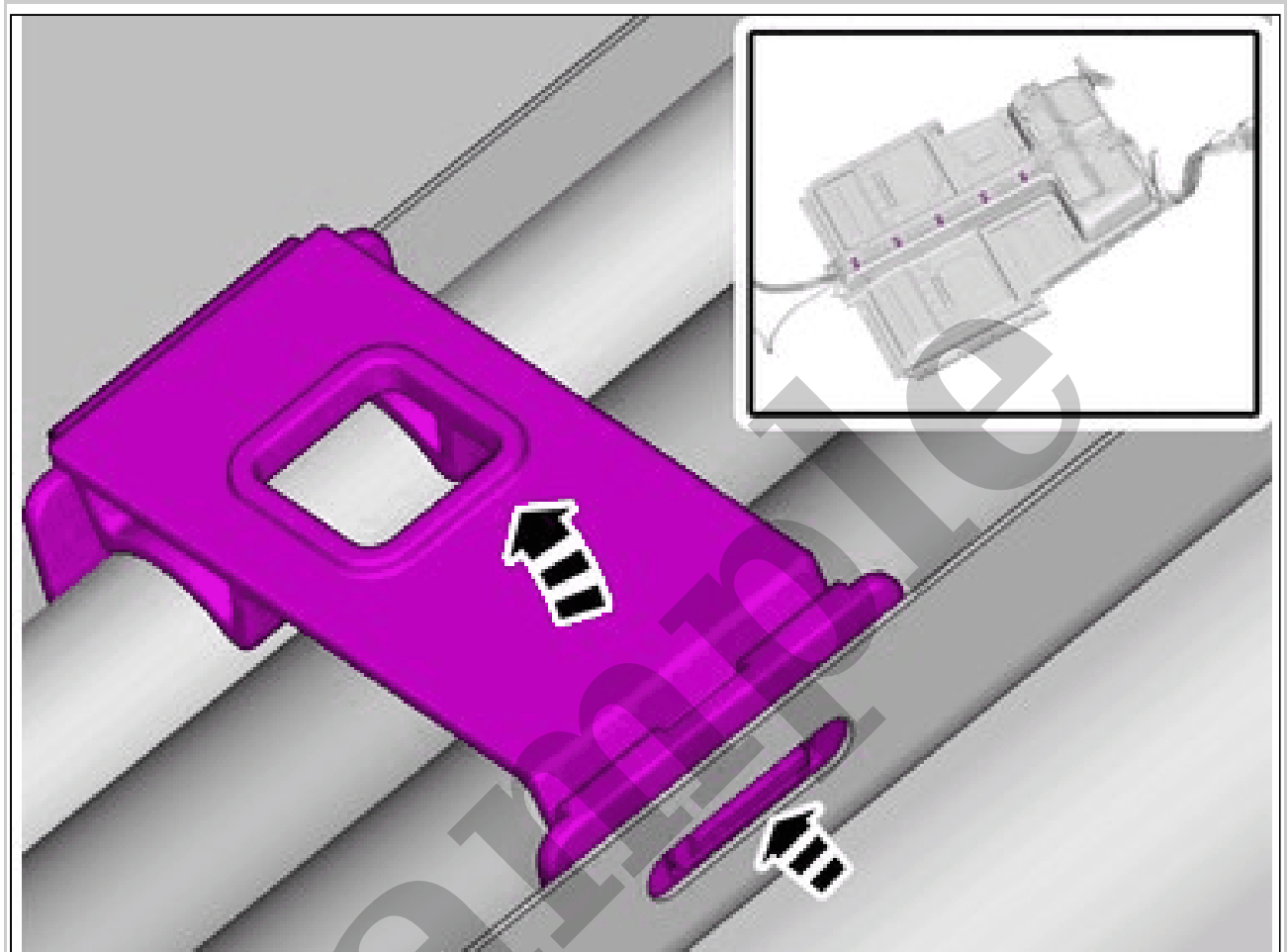

Courtesy of VOLVO CARS CORPORATION

Loosen the clips.

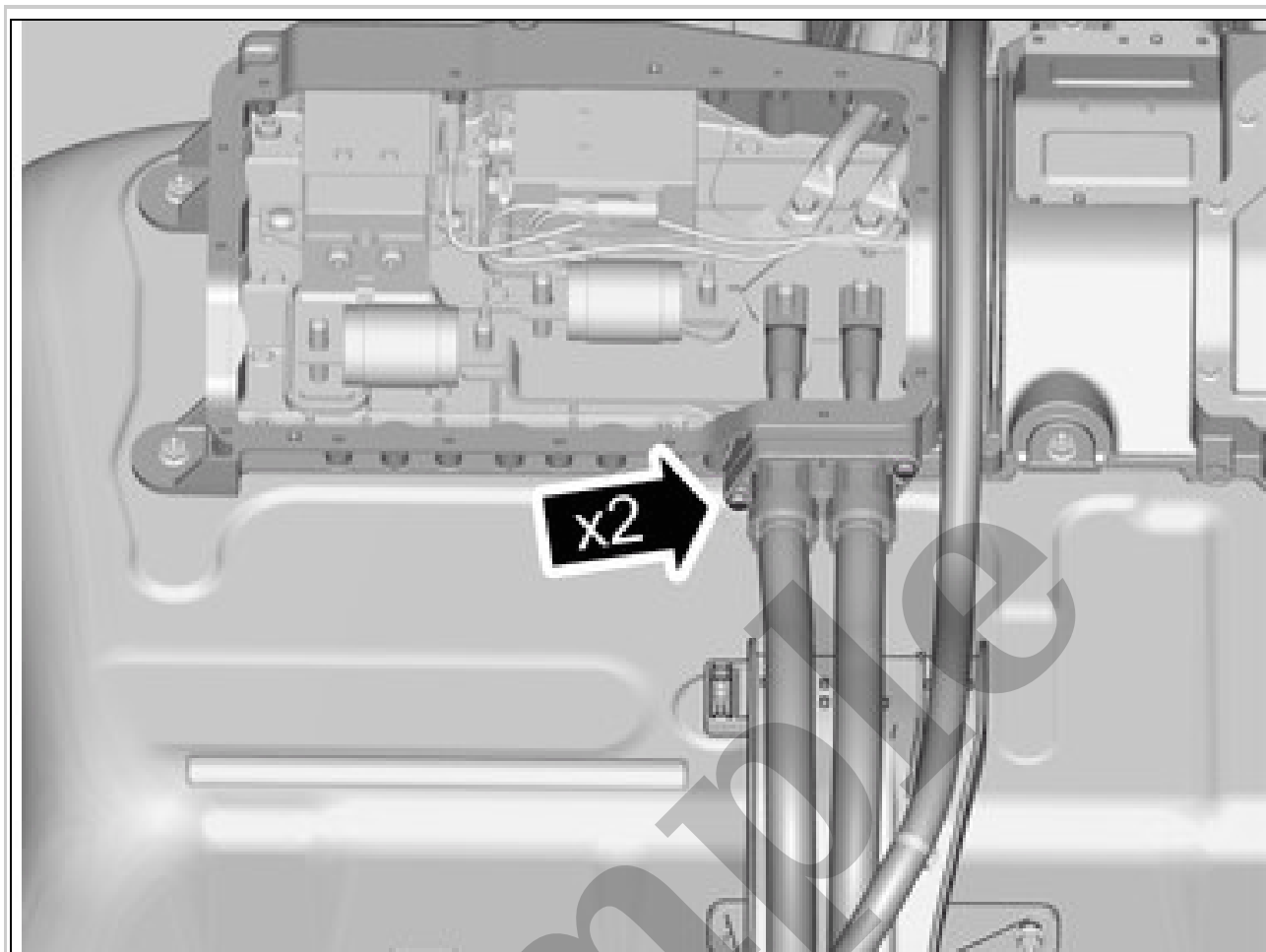

Courtesy of VOLVO CARS CORPORATION

Remove the screws.

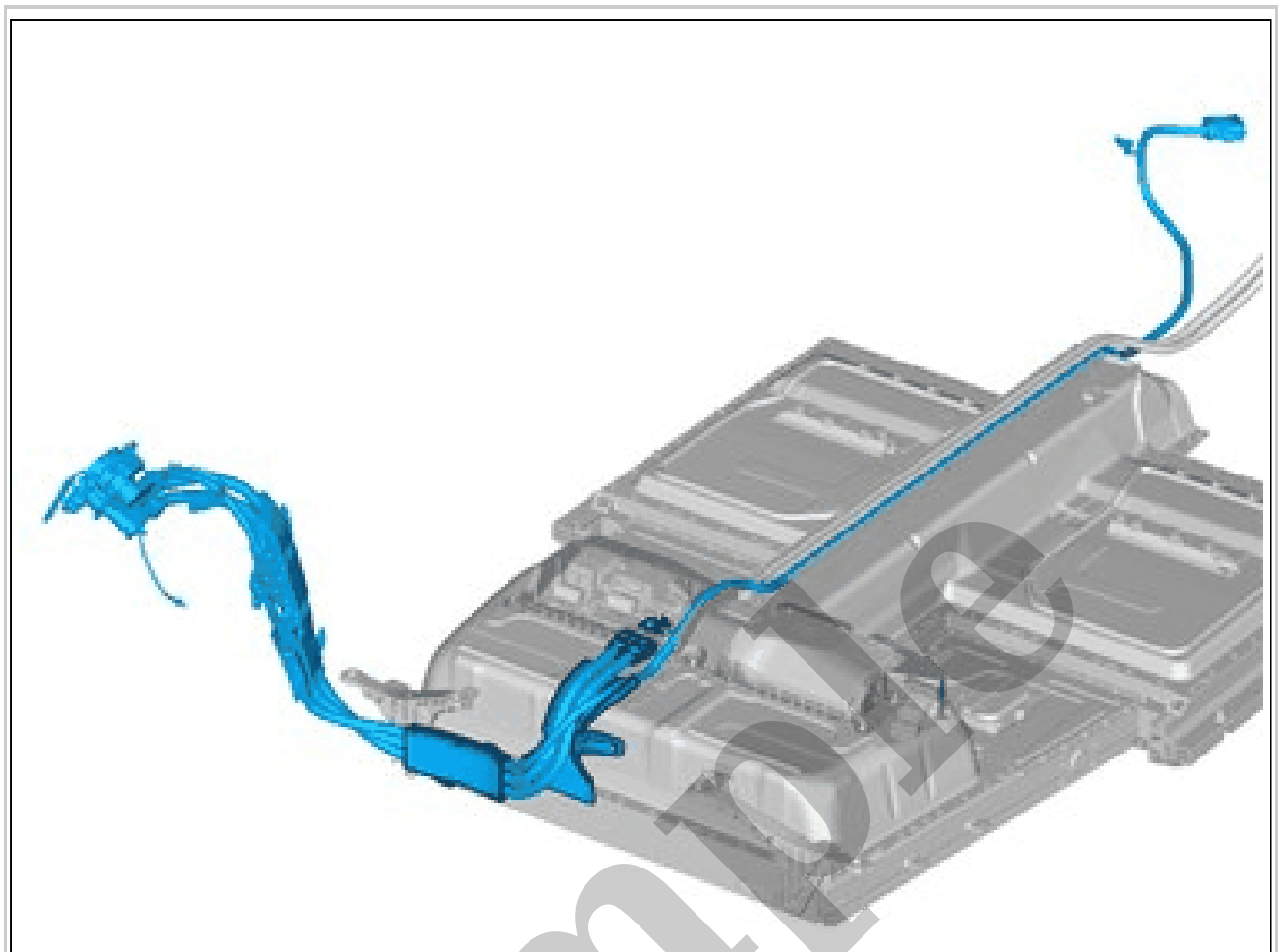

Courtesy of VOLVO CARS CORPORATION

Remove the marked part.

**INSTALLATION**

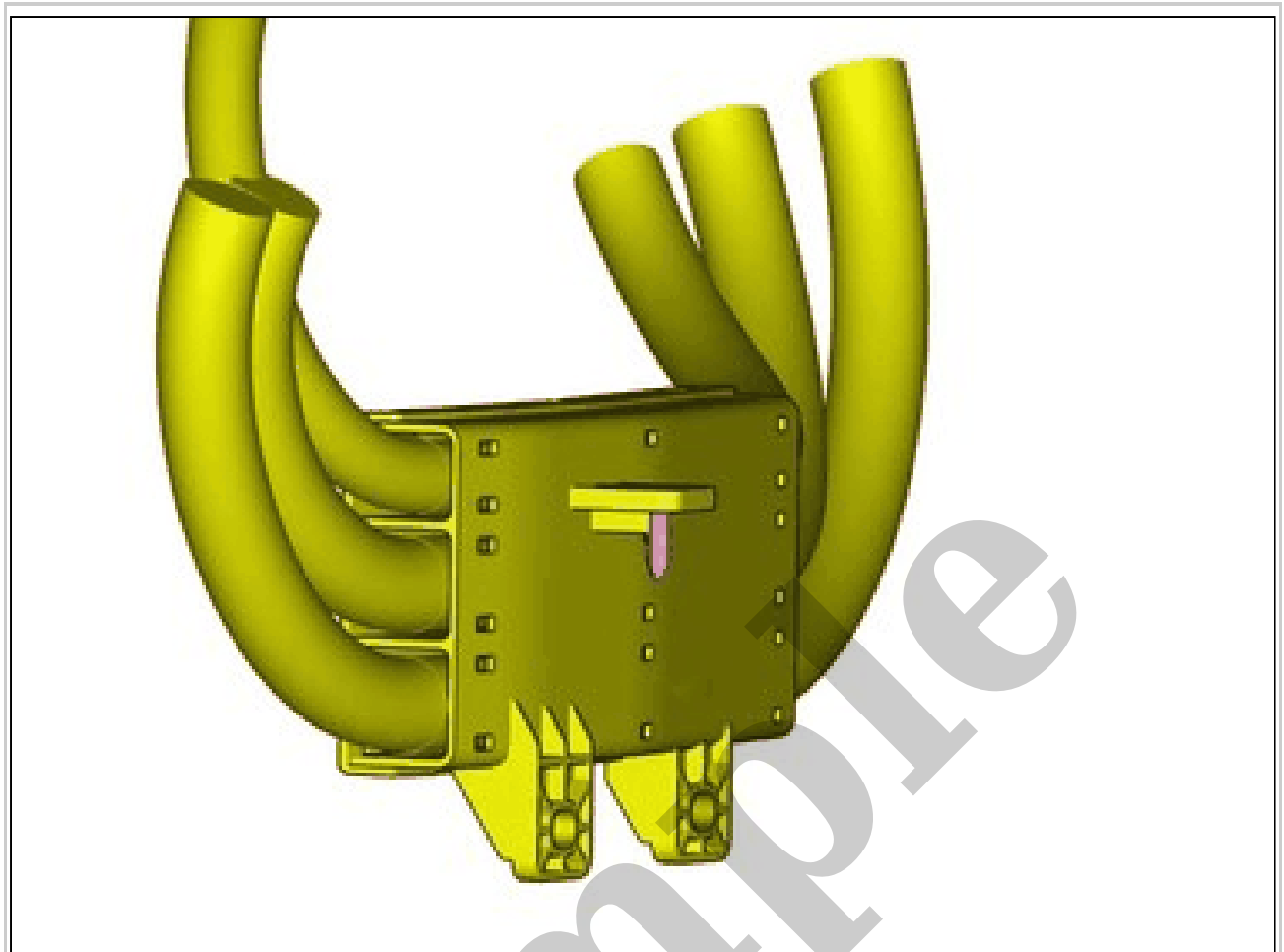

Courtesy of VOLVO CARS CORPORATION

The graphic shows the back of the component.

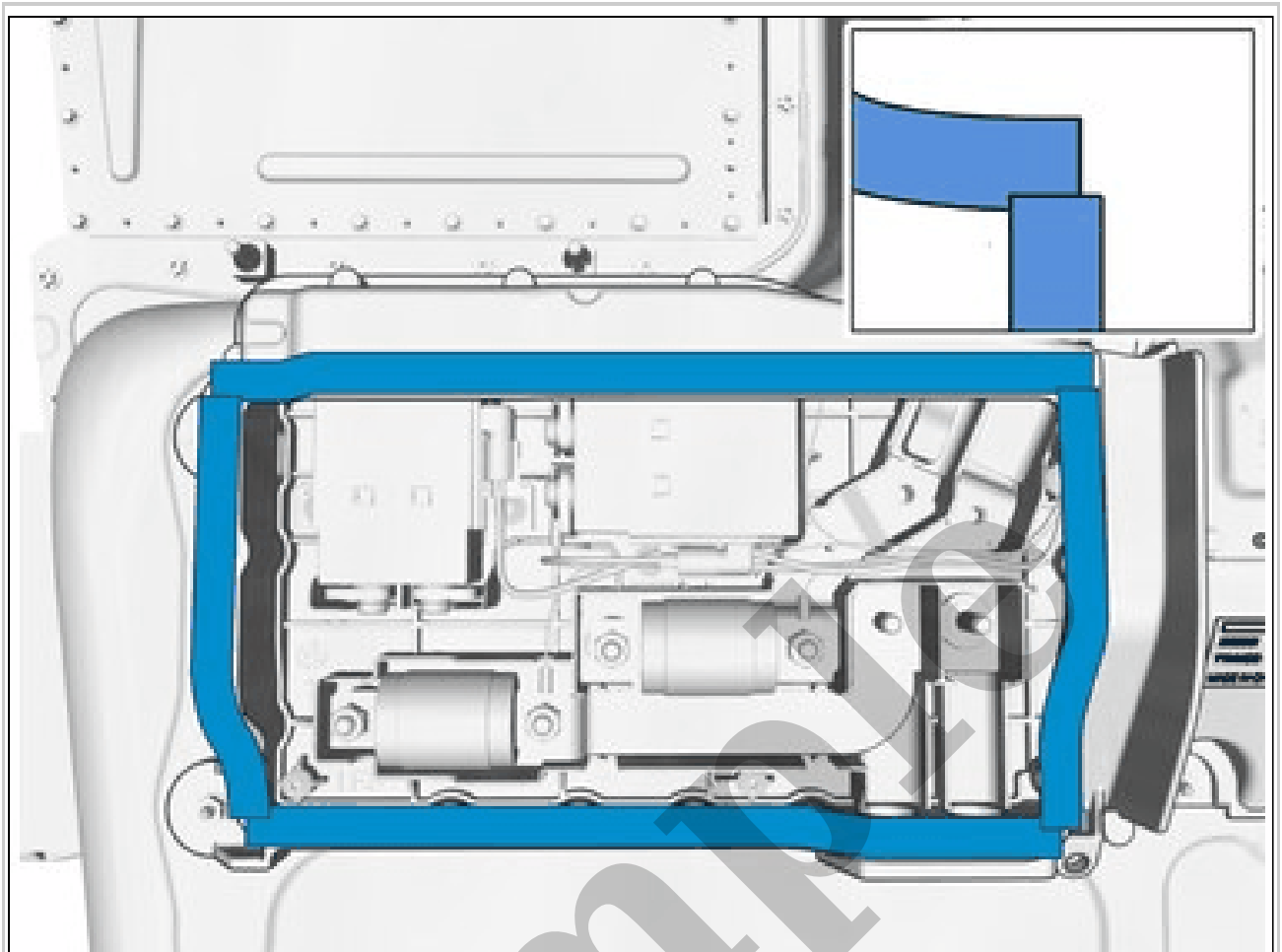

Courtesy of VOLVO CARS CORPORATION

**NOTE:** *Do not remove the protective film.*

New sealing.  
Note the position.  
**Use:** Butyl tape,

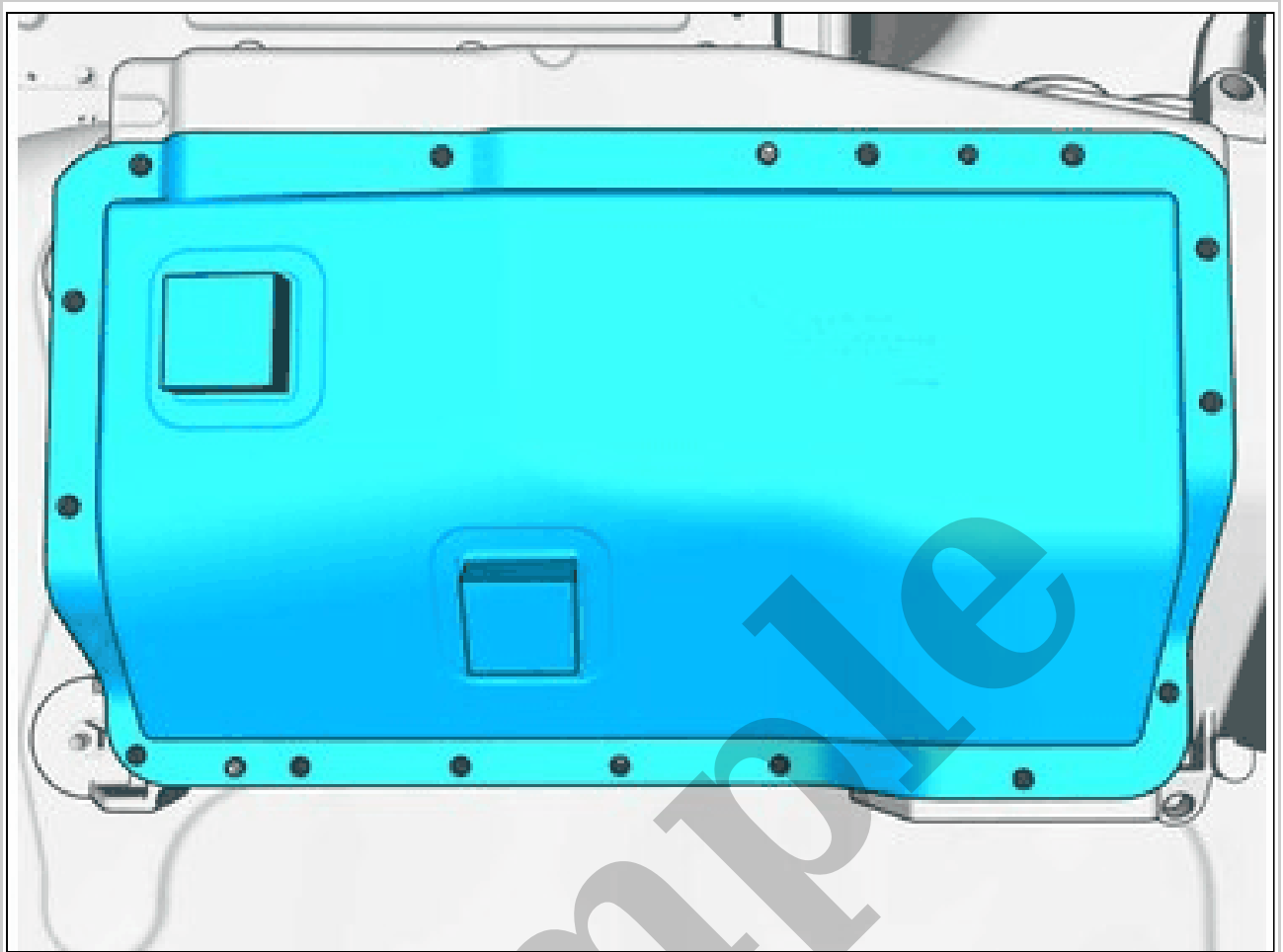

Courtesy of VOLVO CARS CORPORATION

Remove the marked part.

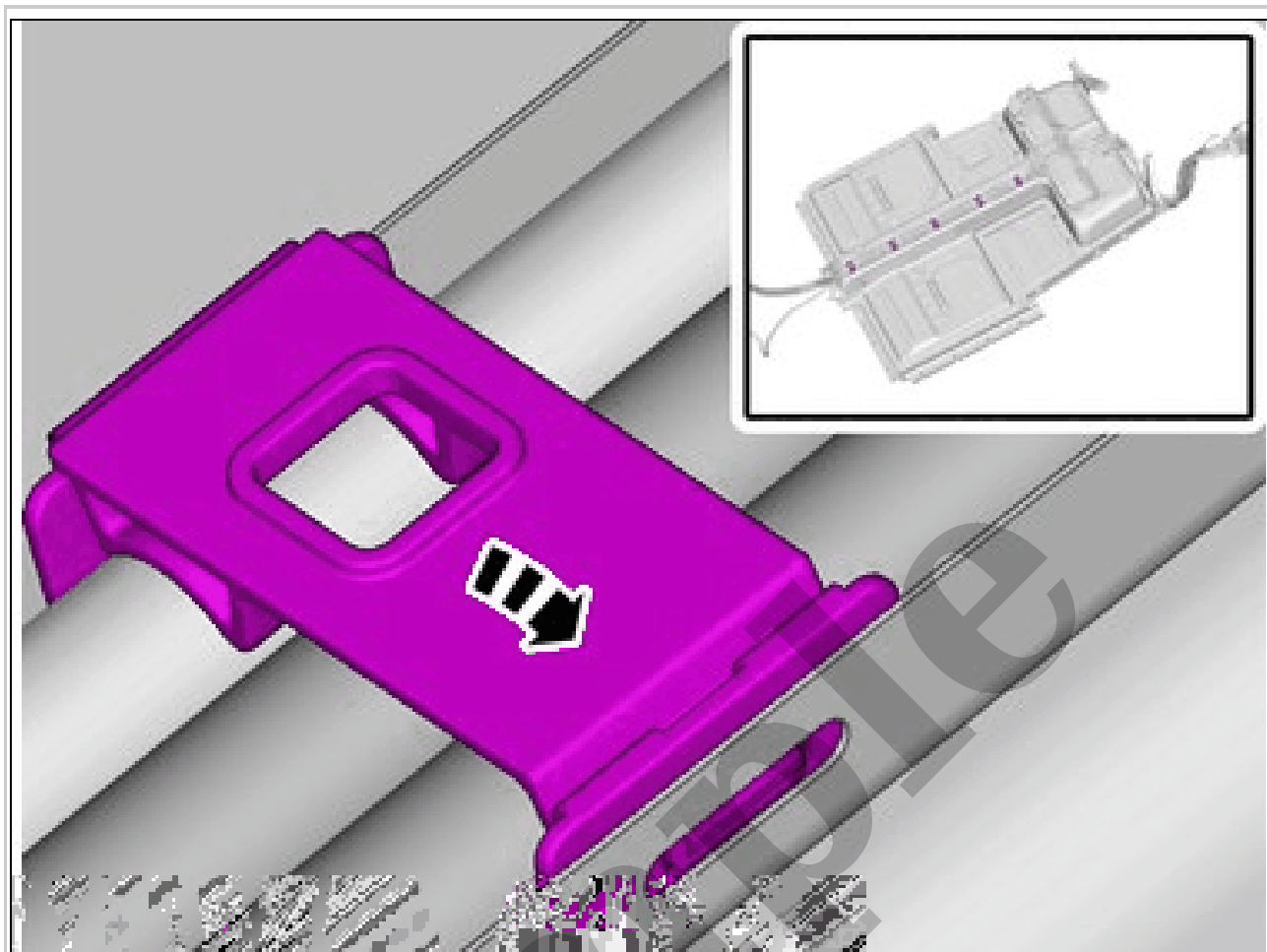

Courtesy of VOLVO CARS CORPORATION

Press the clip(s) into position.



## DIAGNOSTIC SOCKET OBD 2 > DIAGNOSTIC SOCKET OBD 2 [2018-2022] > REMOVAL

Set the vehicle to Inactive mode, described in user mode. Refer to: USAGE MODE

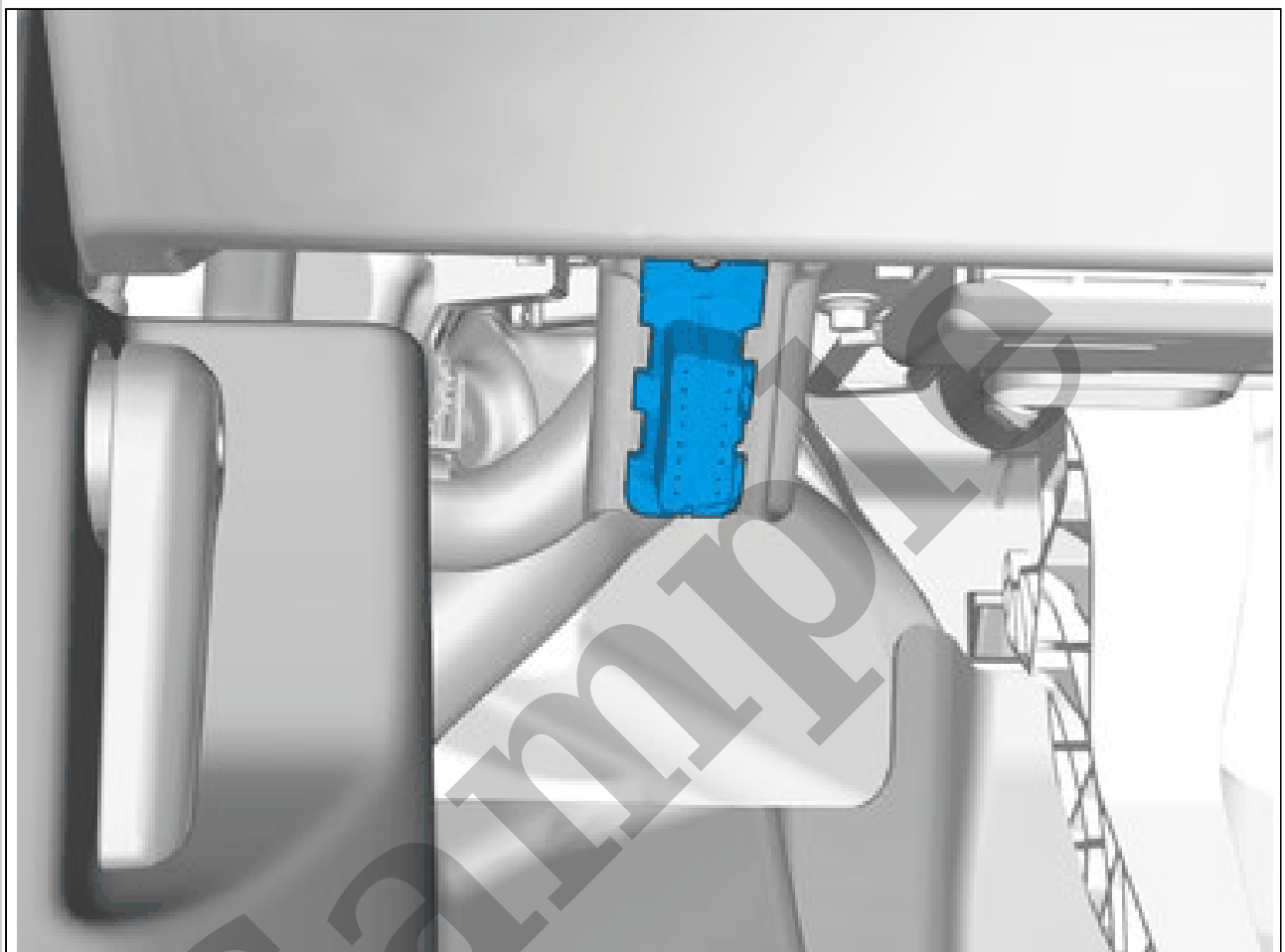

Courtesy of VOLVO CARS CORPORATION

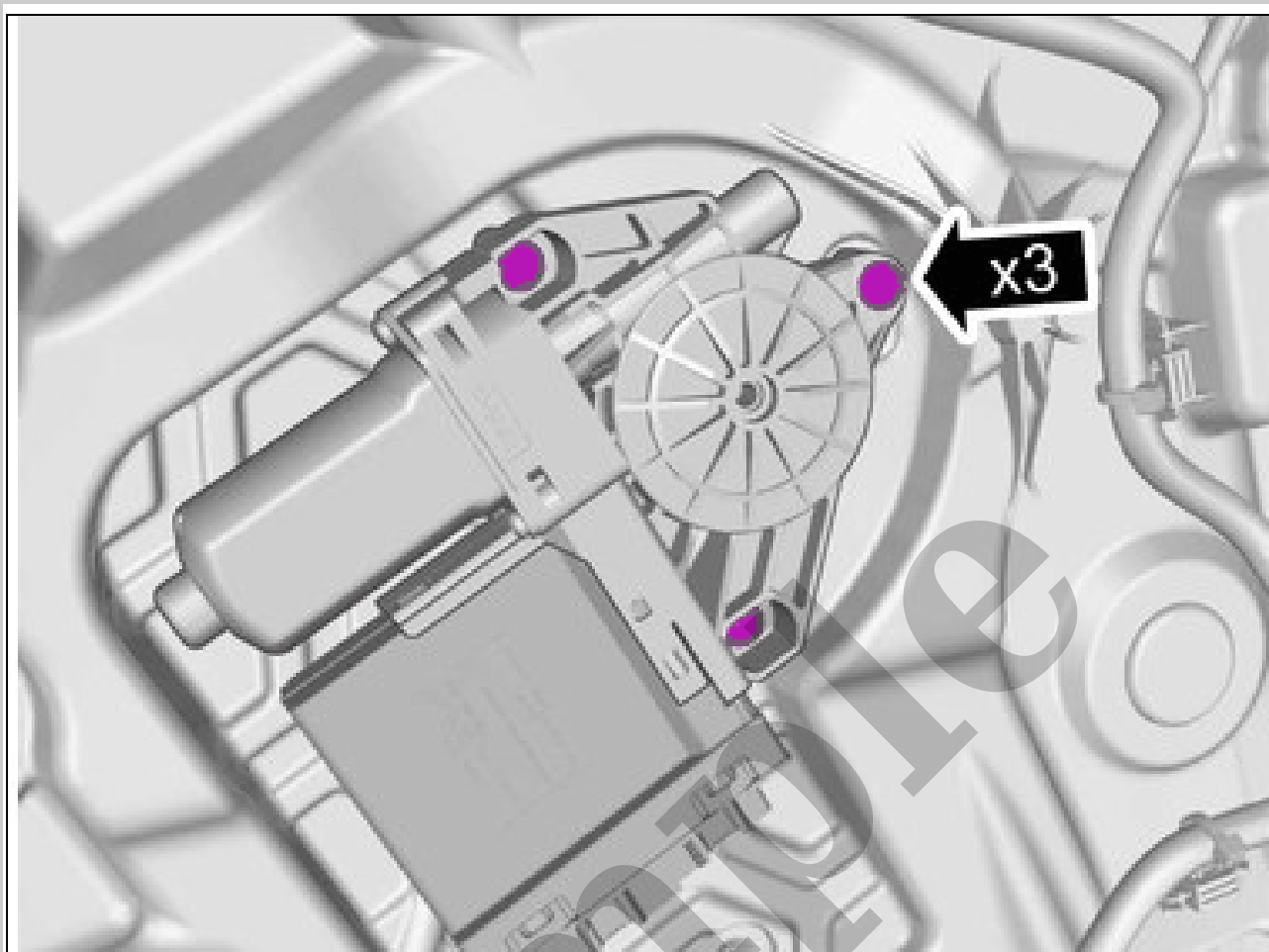

Courtesy of VOLVO CARS CORPORATION

Remove the screws.