

Your Ultimate Source for OEM Repair Manuals

FactoryManuals.net is a great resource for anyone who wants to save money on repairs by doing their own work. The manuals provide detailed instructions and diagrams that make it easy to understand how to fix a vehicle.

1991 VOLVO 940 OEM Service and Repair Workshop Manual

[Go to manual page](#)

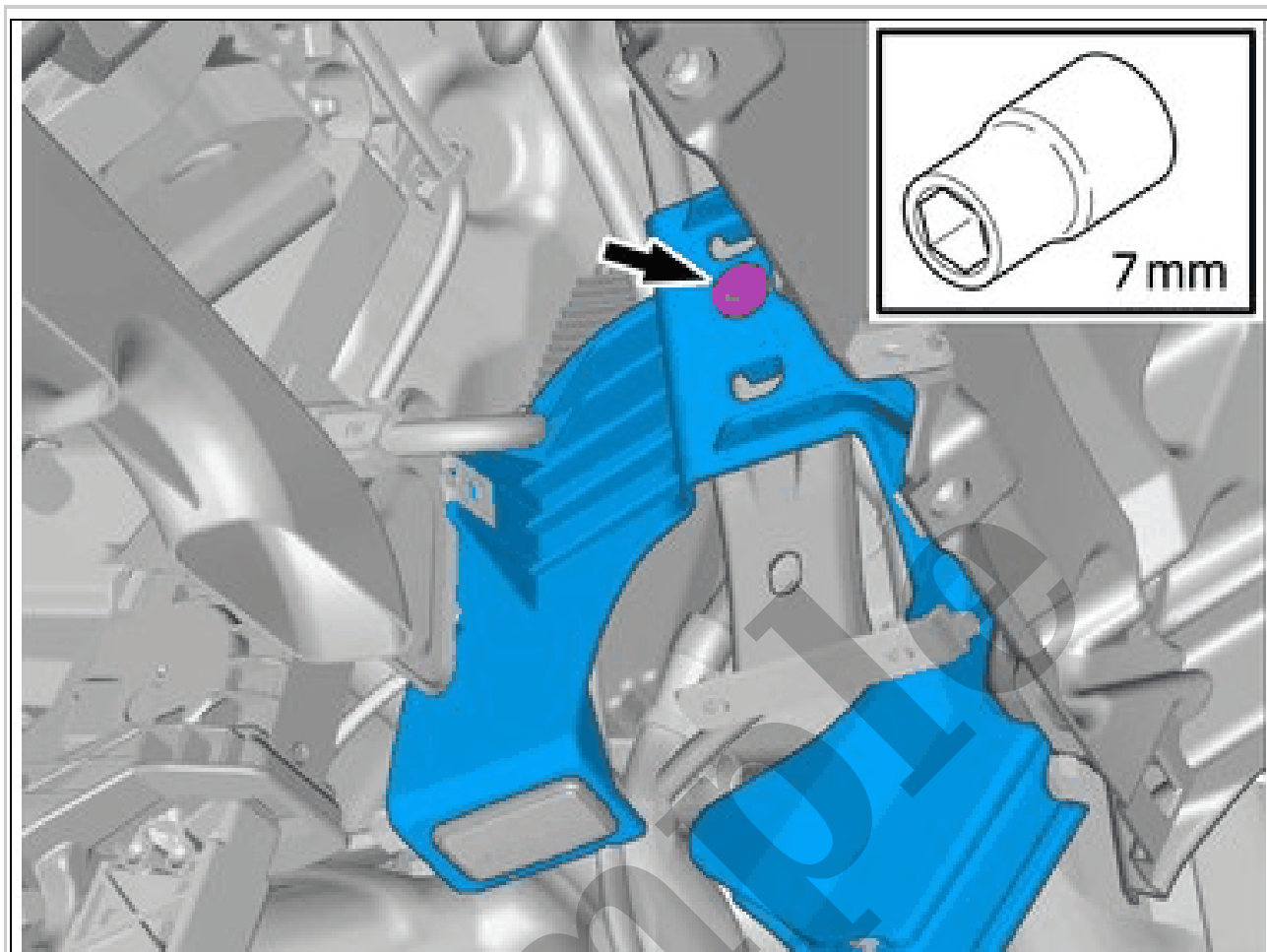

Courtesy of VOLVO CARS CORPORATION

View from below
Remove the nut.
Remove the marked part.

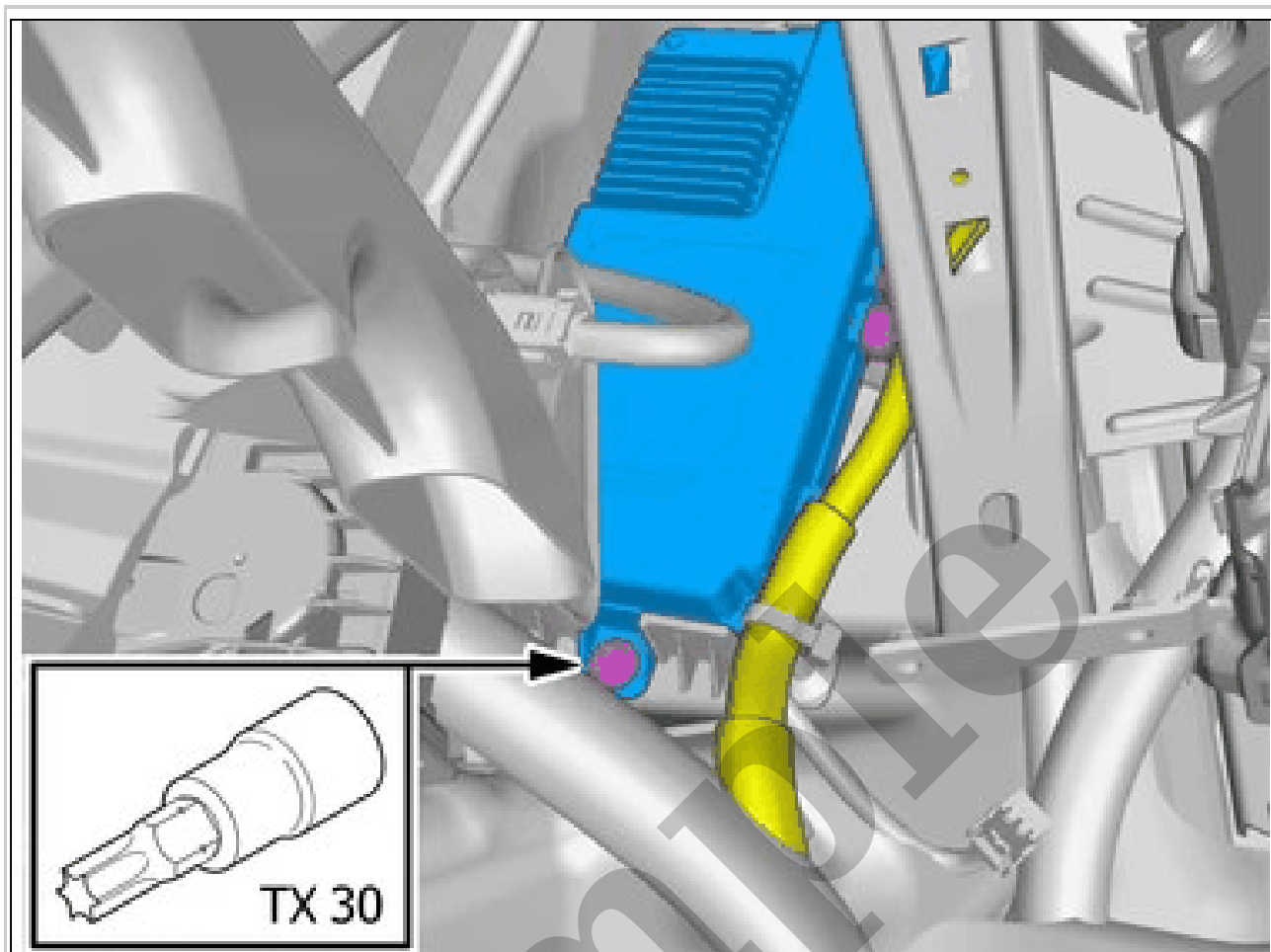

Courtesy of VOLVO CARS CORPORATION

Remove the screw.
Remove the marked part.

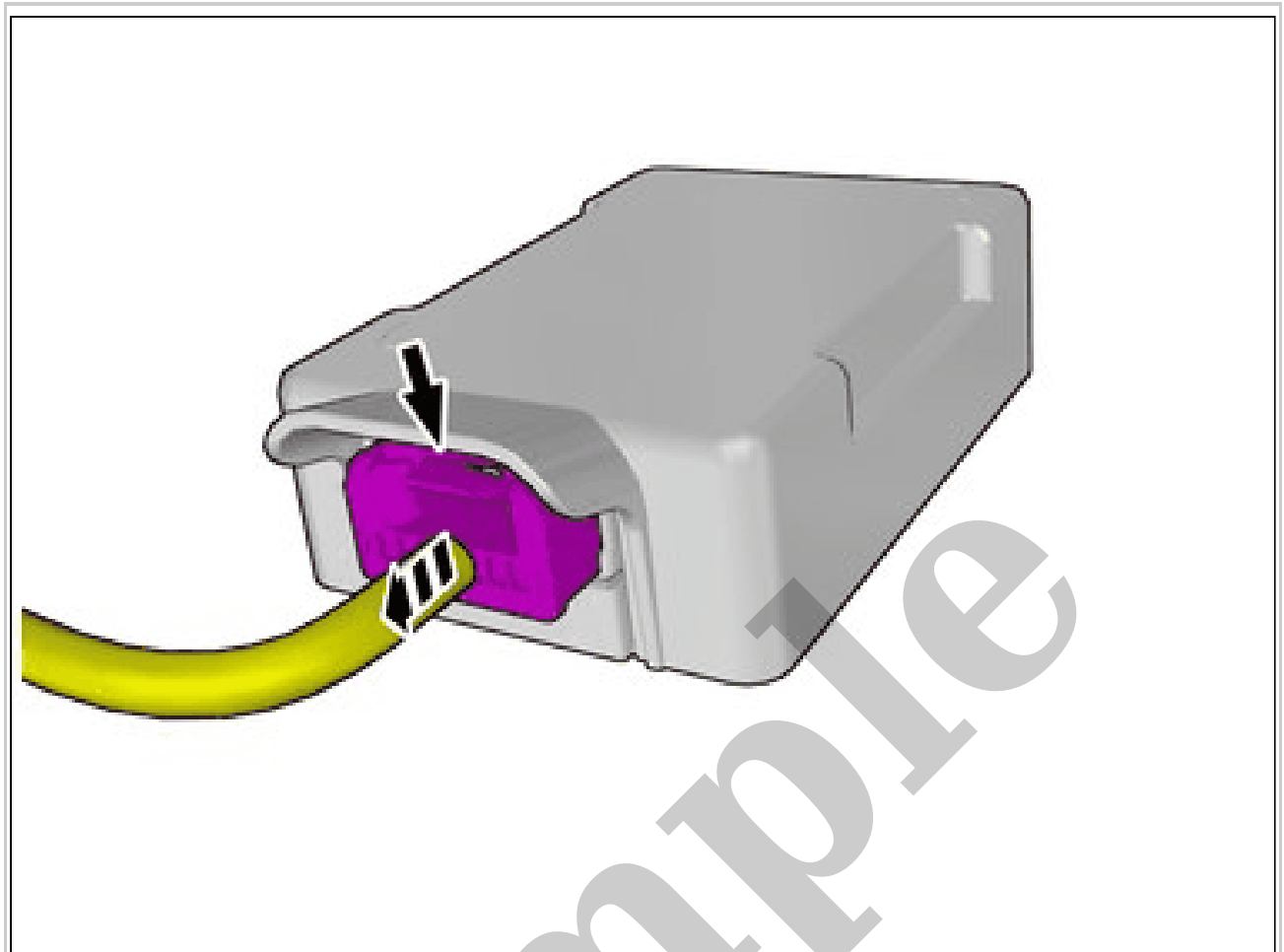

Courtesy of VOLVO CARS CORPORATION

Depress the locking device.
Disconnect the connector.

OBD FIREWALL MODULE > OBD FIREWALL MODULE (OFM) [2018-2020] > INSTALLATION

To install, reverse the removal procedure.

WIRELESS PHONE CHARGER > WIRELESS PHONE CHARGER (WPC) [2018-2022] > REMOVAL

Set the vehicle to Inactive mode, described in user mode. Refer to: USAGE MODE

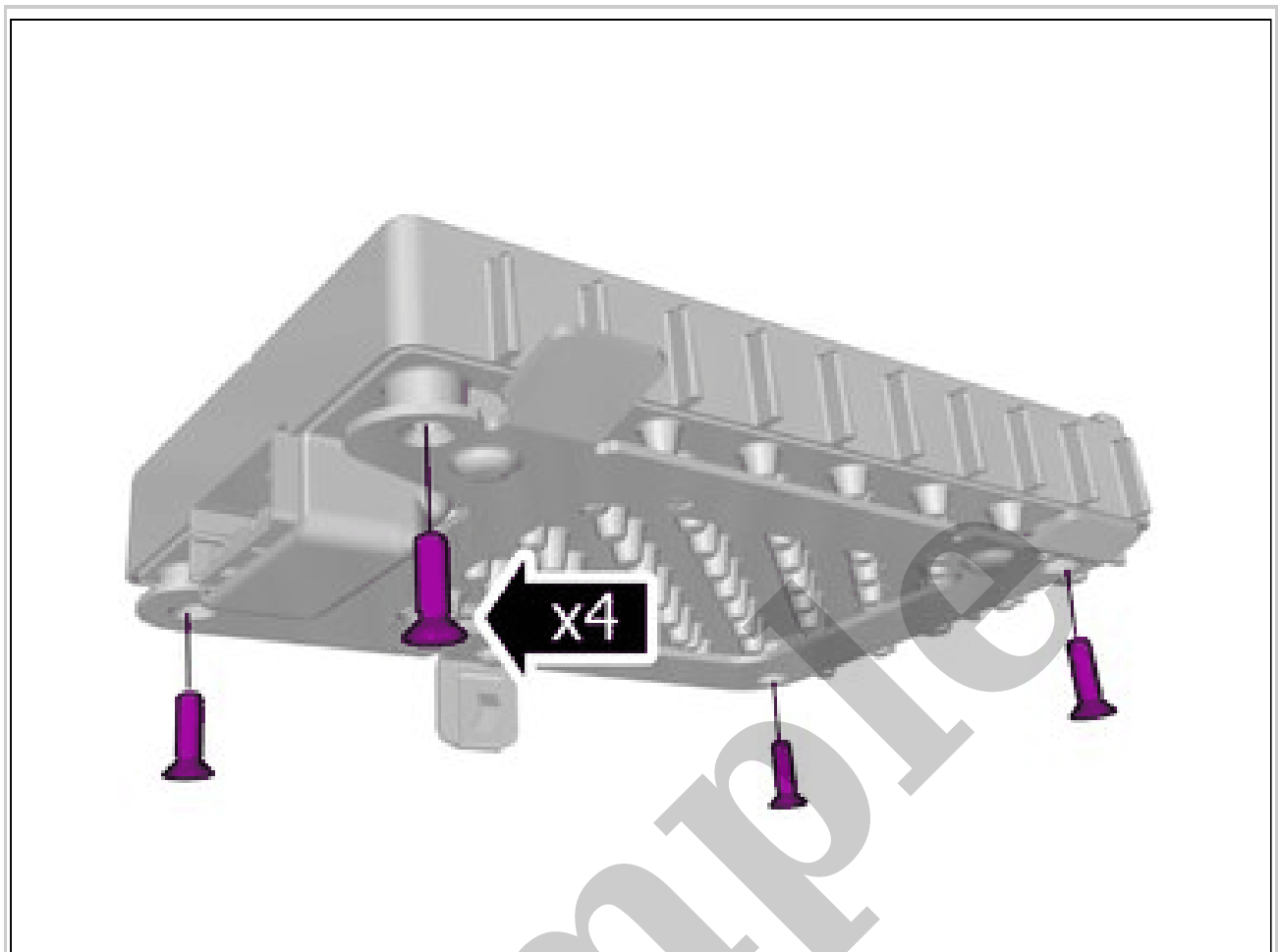

Courtesy of VOLVO CARS CORPORATION

Loosen the screws.

WIRELESS PHONE CHARGER > WIRELESS PHONE CHARGER (WPC) [2018-2022] > INSTALLATION

To install, reverse the removal procedure.

The Forward Looking Camera 2 (FLC2) is a high definition camera that is mounted behind the windshield, near the rear view mirror. It has a field of view that is 100° horizontal and 39.2° vertical and is used by safety related functions. The FLC2 has built-in heating to prevent the windshield from being fogged up.

FORWARD LOOKING CAMERA 2 > FORWARD LOOKING CAMERA 2 (FLC2) (4/318) [2021-2022, E400V6] > DIAGNOSTIC INFORMATION

The Forward Looking Camera 2 (FLC2) has a built-in diagnostic system, which continuously monitors the control module. The FLC2 sets DTCs and has readable parameters.

FORWARD LOOKING CAMERA 2 > FORWARD LOOKING CAMERA 2 (FLC2) (4/318) [2021-2022, E400V6] > CONNECTION AND COMMUNICATION

The Forward Looking Camera 2 (FLC2) is a FlexRay slave and communicates with the Active Safety Domain Master (ASDM).

FORWARD LOOKING RADAR > FORWARD LOOKING RADAR (FLR) (4/291) [2021- 2022, E400V6] > DESCRIPTION

The Forward Looking Radar (FLR) is mounted in the grill in the front of the vehicle. It identifies objects in front of the vehicle when using safety related functions. There is heating in the cover of the radar to prevent ice from building up.

FORWARD LOOKING RADAR > FORWARD LOOKING RADAR (FLR) (4/291) [2021- 2022, E400V6] > DIAGNOSTIC INFORMATION

The Forward Looking Radar (FLR) has a built-in diagnostic system, which continuously monitors the control module. The FLR sets DTCs and has readable parameters.

FORWARD LOOKING RADAR > FORWARD LOOKING RADAR (FLR) (4/291) [2021- 2022, E400V6] > CONNECTION AND COMMUNICATION

The Forward Looking Radar (FLR) is a CAN slave and communicates with the Active Safety Domain Master (ASDM).

PARKING ASSISTANCE CAMERA > PARKING ASSISTANCE CAMERA (27/6 - 27/8, 27/11) [2018-2022] > DESCRIPTION

The parking assistance camera is a satellite camera that scans the vehicle surroundings and provides a Low-Voltages Differential Signal LVDS video signal output.

PARKING ASSISTANCE CAMERA > PARKING ASSISTANCE CAMERA (27/6 - 27/8, 27/11) [2018-2022] > DIAGNOSTIC INFORMATION



Courtesy of VOLVO CARS CORPORATION

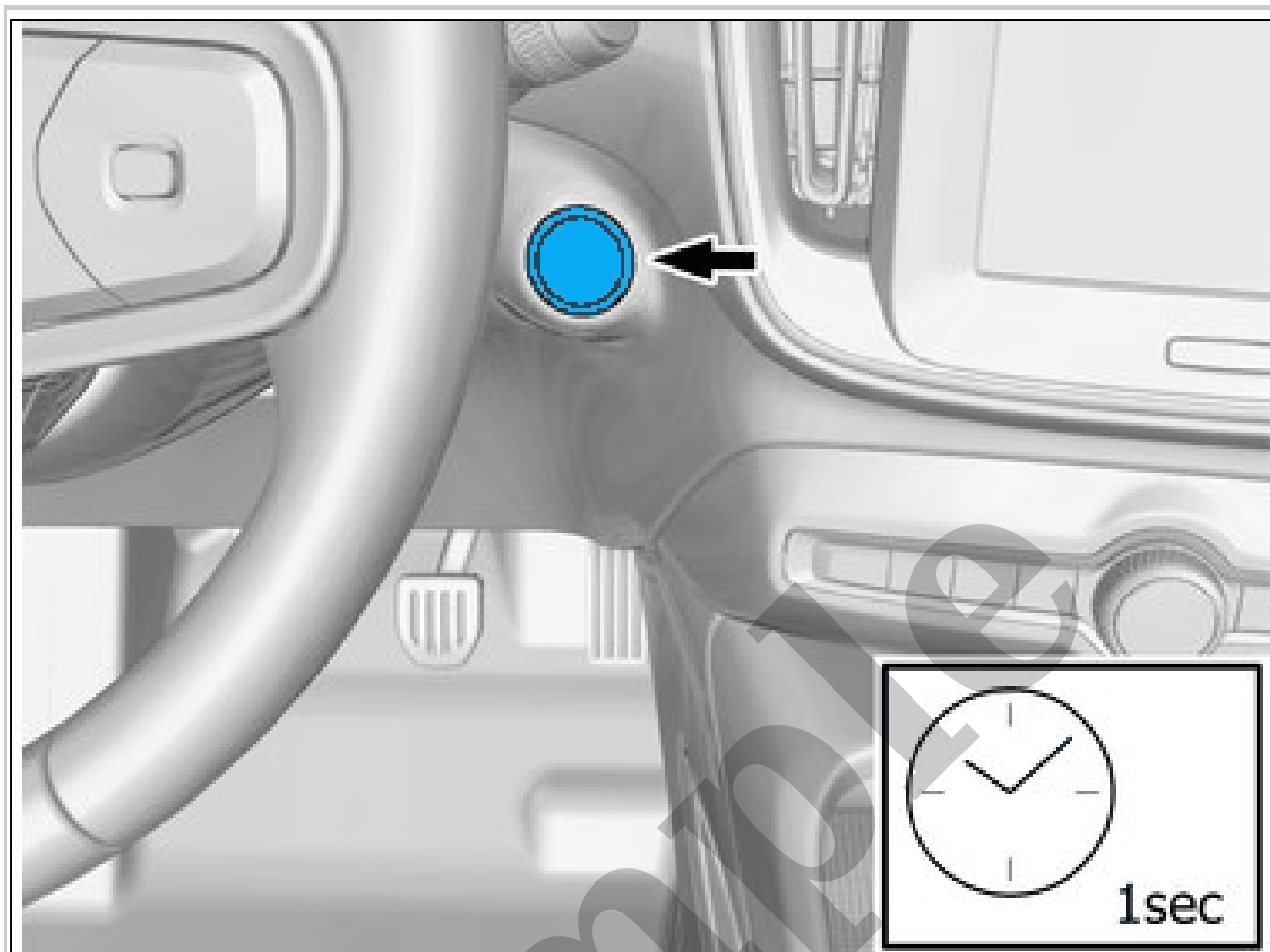

Courtesy of VOLVO CARS CORPORATION

REMOVAL

NOTE: *The removal steps may contain installation details.*

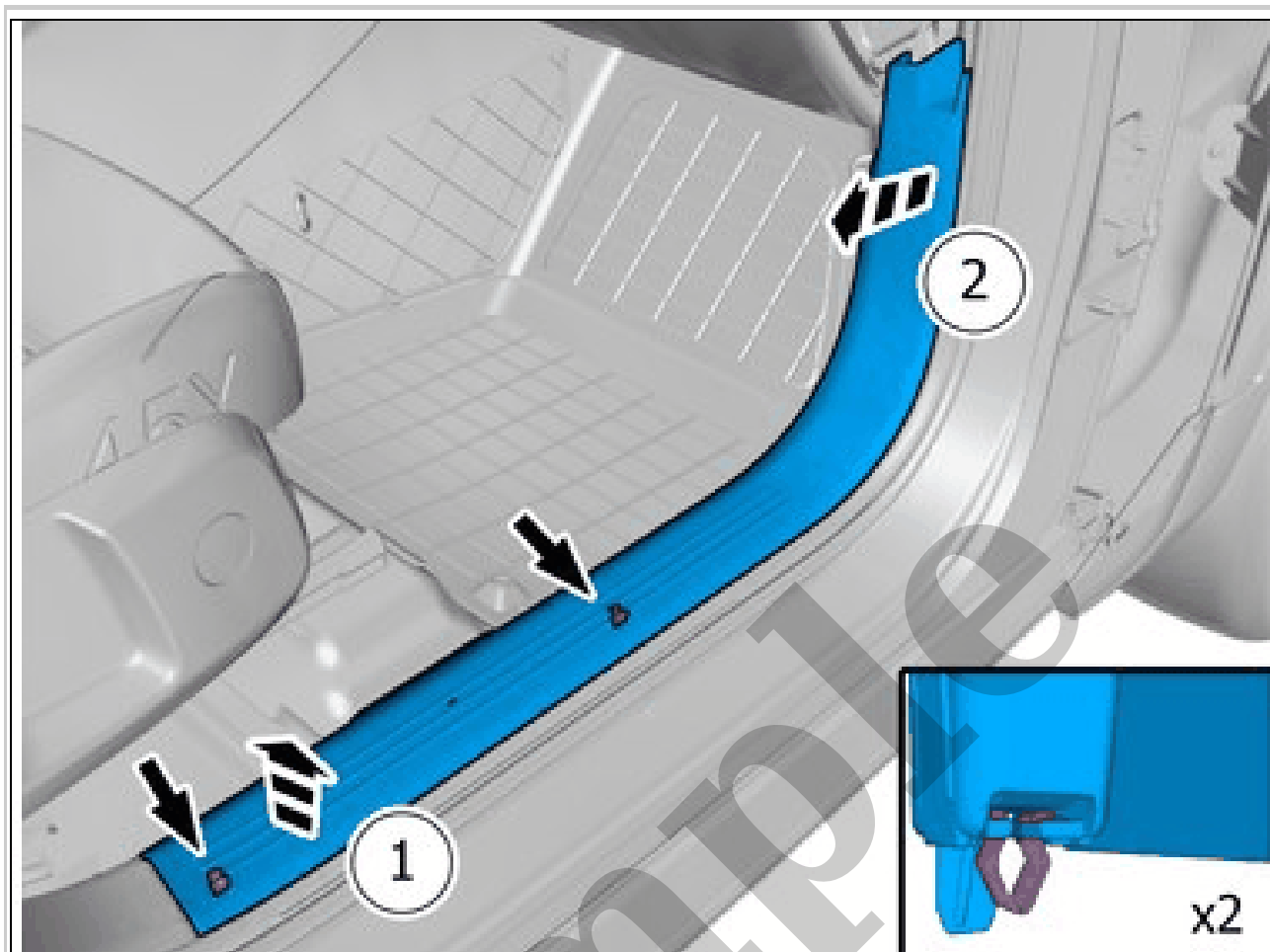

Courtesy of VOLVO CARS CORPORATION

Remove the panel.
Disconnect the connector, if applicable.

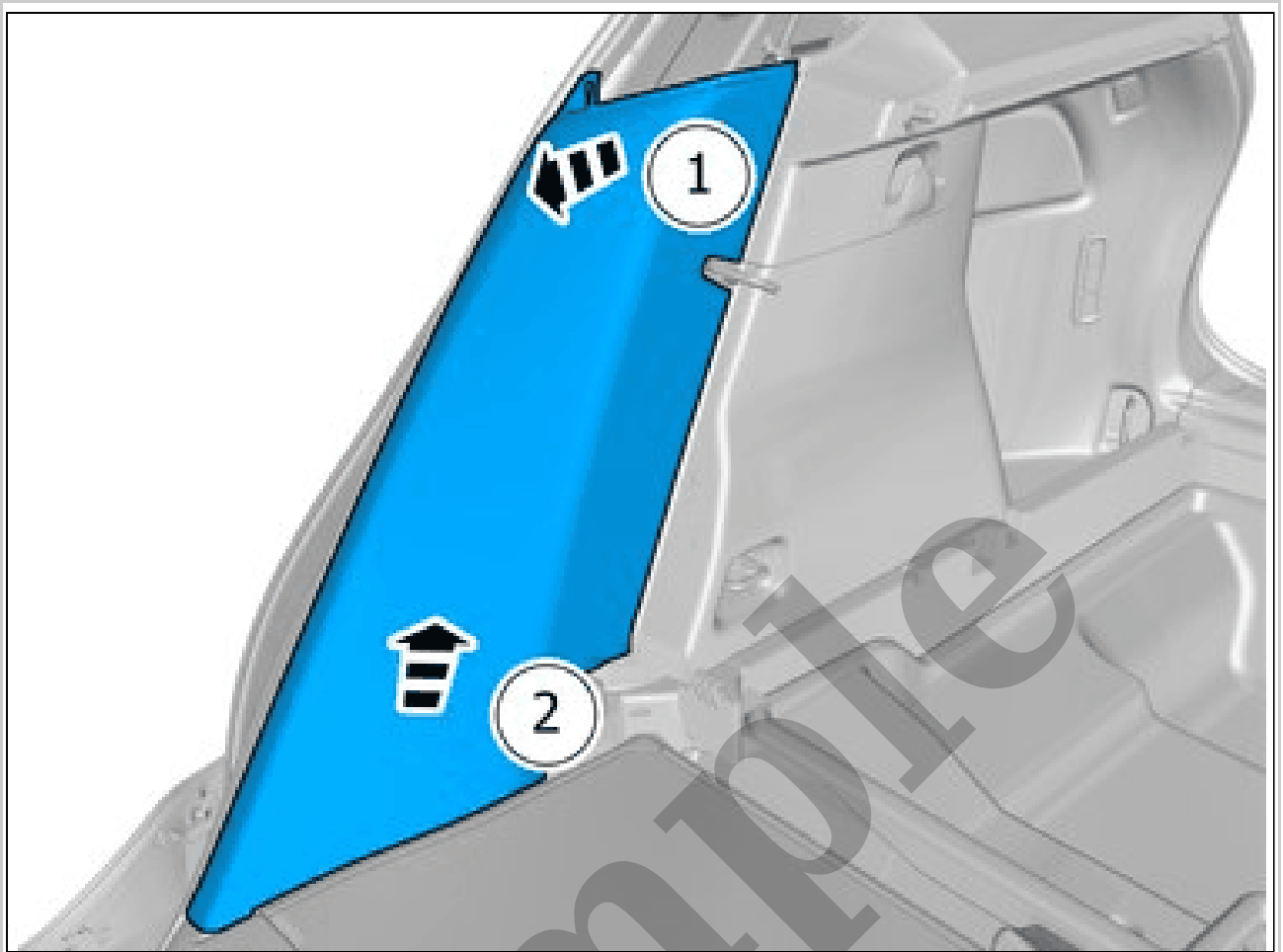

Courtesy of VOLVO CARS CORPORATION

Remove the marked part.