

Your Ultimate Source for OEM Repair Manuals

FactoryManuals.net is a great resource for anyone who wants to save money on repairs by doing their own work. The manuals provide detailed instructions and diagrams that make it easy to understand how to fix a vehicle.

1991 FORD Fiesta 3 Doors OEM Service and Repair Workshop Manual

[Go to manual page](#)

Refer to: [Joining Techniques](#)(501-25 Body Repairs - General Information, General Procedures).

Use the General Equipment: Self-Piercing Rivet (SPR) Remover/Installer

Use the General Equipment: Blind Rivet Gun

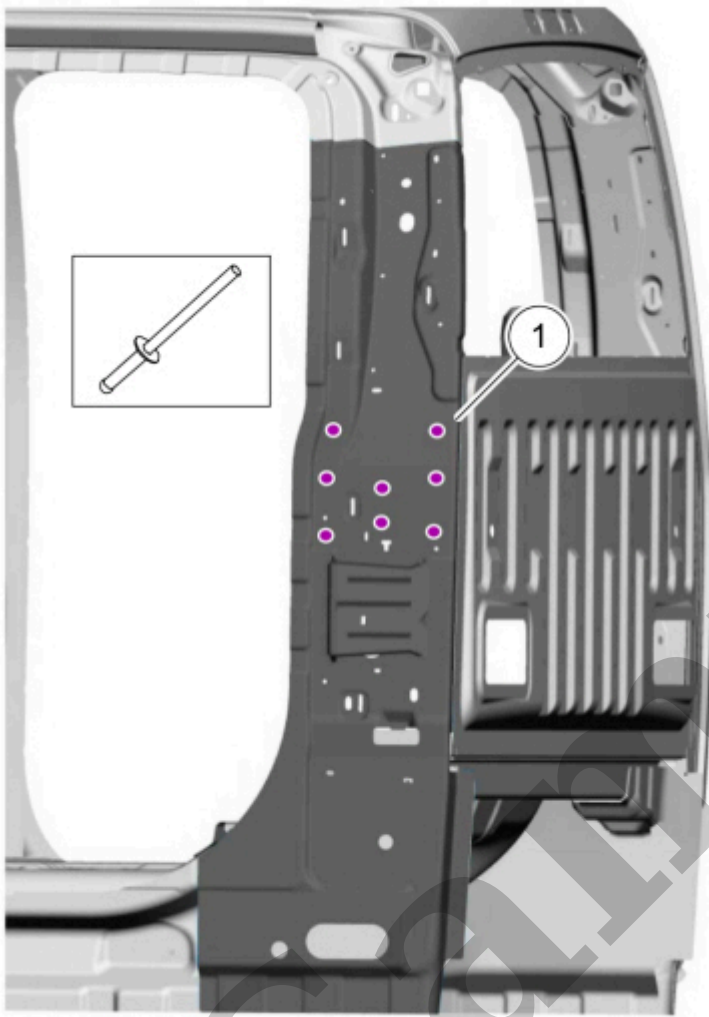

E199467

[Click here to learn about symbols, color coding, and icons used in this manual.](#)

7. Sand using 80 grit sand paper to remove e-coat and clean.

[Click here to learn about symbols, color coding, and icons used in this manual.](#)

9. Install the C-pillar reinforcement and clamp in position.

Use the General Equipment: Locking Pliers

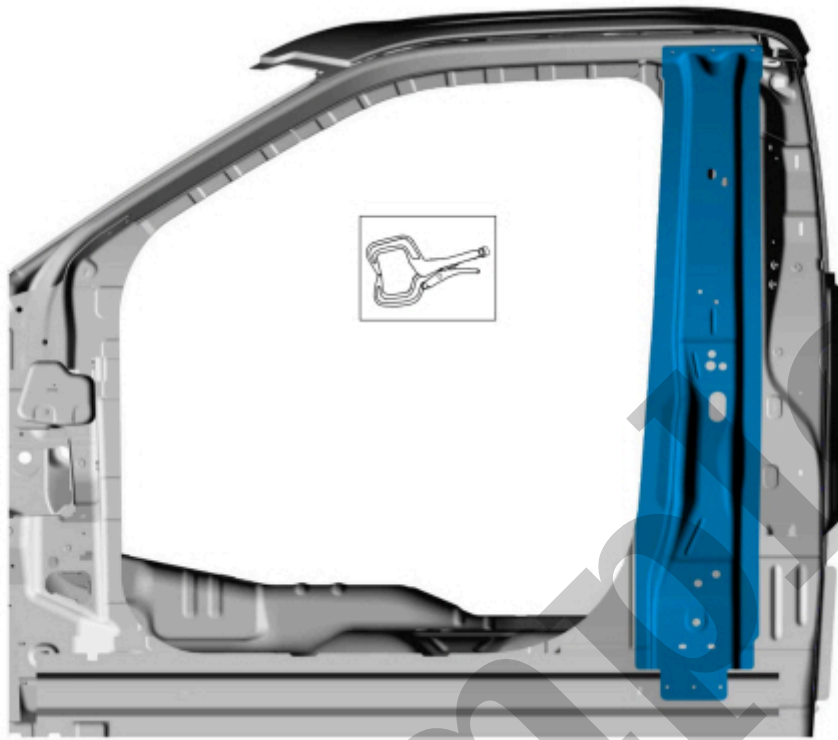

E201738

[Click here to learn about symbols, color coding, and icons used in this manual.](#)

10. Drill 6.5 mm holes for blind rivet fastener installation.

Use the General Equipment: 6.5 mm Drill Bit

2	-	-	-	-	W702512-S900C	-	-
---	---	---	---	---	---------------	---	---

Use the General Equipment: Blind Rivet Gun

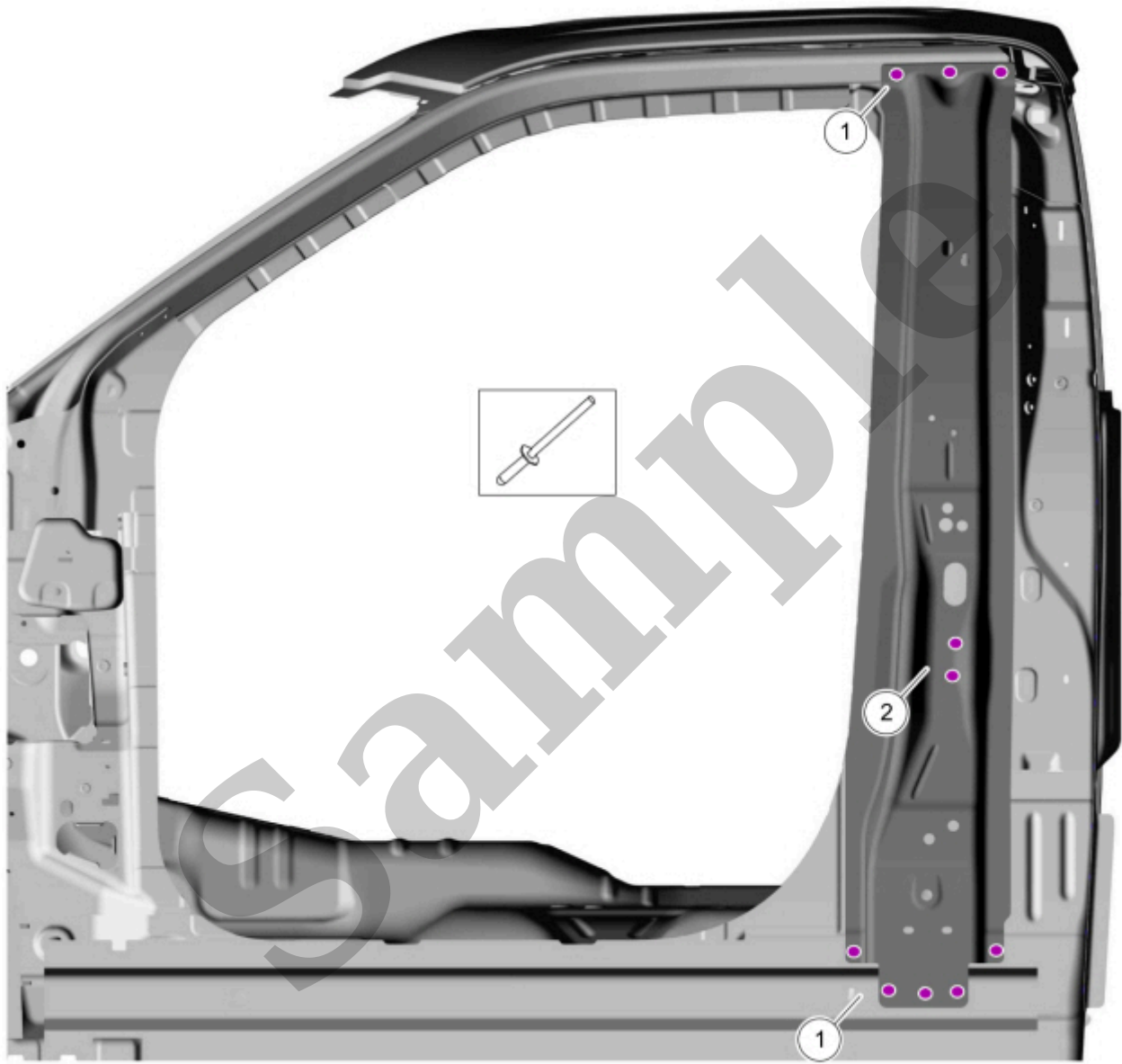

E201740

[Click here to learn about symbols, color coding, and icons used in this manual.](#)

SuperCab

12. Drill for fasteners.

Use the General Equipment: 6.5 mm Drill Bit

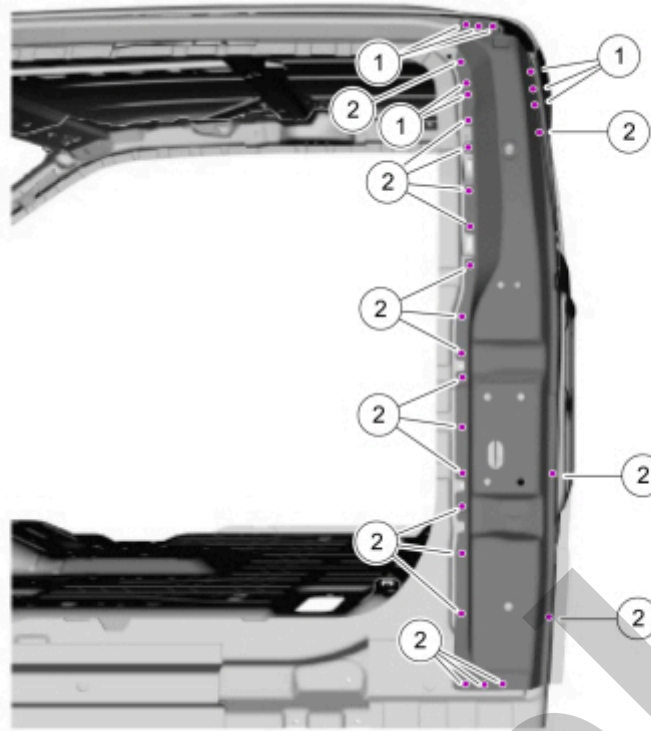

E257293

[Click here to learn about symbols, color coding, and icons used in this manual.](#)

All vehicles

14. **NOTE**

SuperCrew cab shown, regular and SuperCab similar.

Cut the service panel to fit repair area.

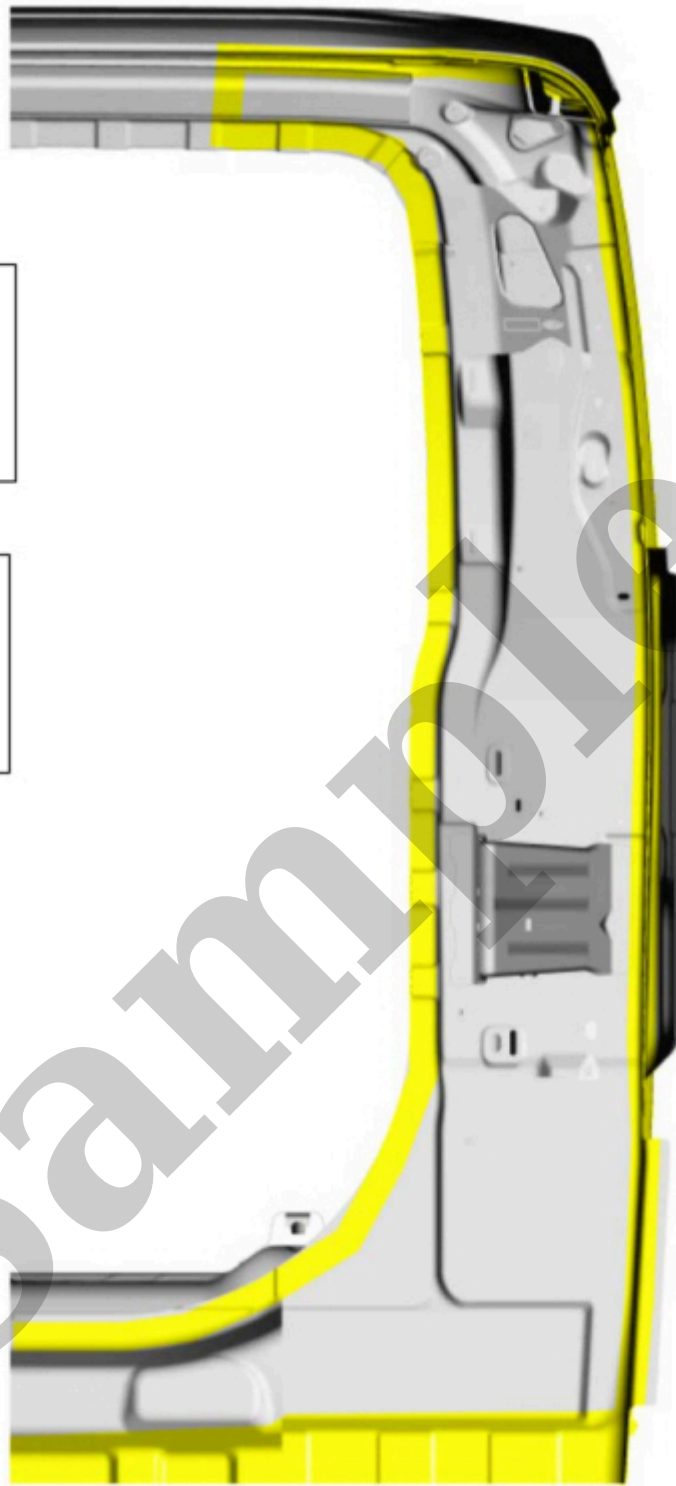
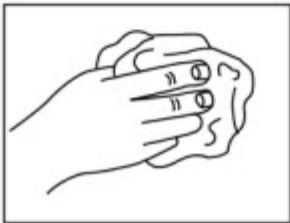
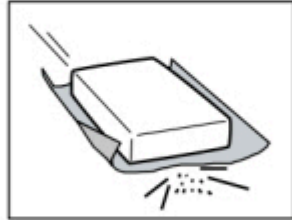

E199479

[Click here to learn about symbols, color coding, and icons used in this manual.](#)

17. Sand the service panel mating surfaces using 80 grit sand paper to remove e-coat and clean.

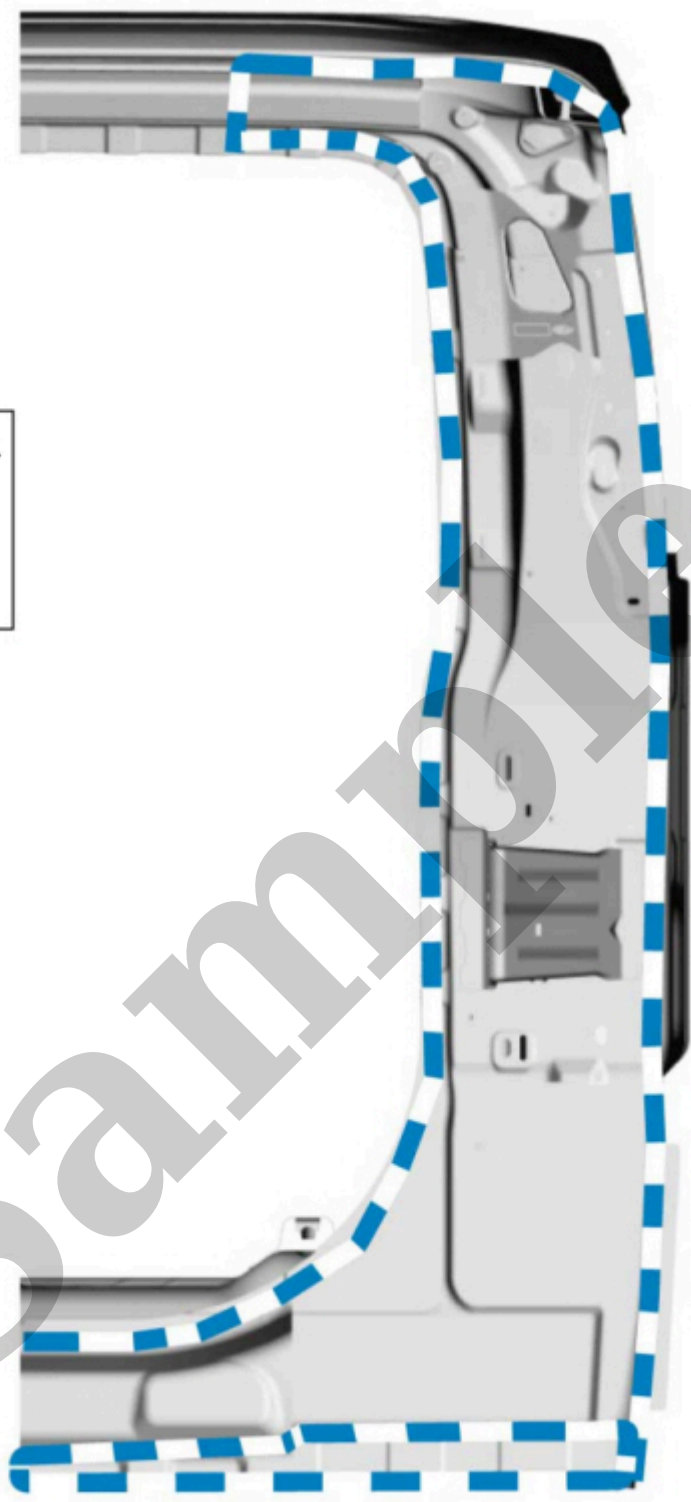

E199481

[Click here to learn about symbols, color coding, and icons used in this manual.](#)

19. Install service panel and clamp in position.

Use the General Equipment: Locking Pliers



E331875

[Click here to learn about symbols, color coding, and icons used in this manual.](#)

SuperCrew

22. NOTE

SPR (self-piercing rivet) fasteners may not be placed directly over original SPR (self-piercing rivet) location. They must be placed adjacent to original location matching original quantity.

Install the fasteners.

Item	SPR (self-piercing rivet) Number	SPR (self-piercing rivet) Code	Henrob® Mandrel	Pro-Spot® Mandrel	Blind Rivet	Solid Rivet	Rivnut®
1	W708713-S900	AS	DZ09-025/H	SA-0400/SA-0401	-	W790376-S900	-
2	W708717-S900	AW	DP11-200/H	SA-0400/SA-0402	-	W790377-S900	-
3	W717186-S900	EN	DP11-200/H	SA-0400/SA-0402	-	W790377-S900	-

2	W708717-S900	AW	DG10-220/H	SA-0400/SA-0402	-	W790377-S900	-
3	W717186-S900	EN	DP11-200/H	SA-0400/SA-0402	-	W790377-S900	-
4	W710246-S900	BN	DP10-200/H	SA-0400/SA-0402	-	W790377-S900	-

Use the General Equipment: Self-Piercing Rivet (SPR) Remover/Installer

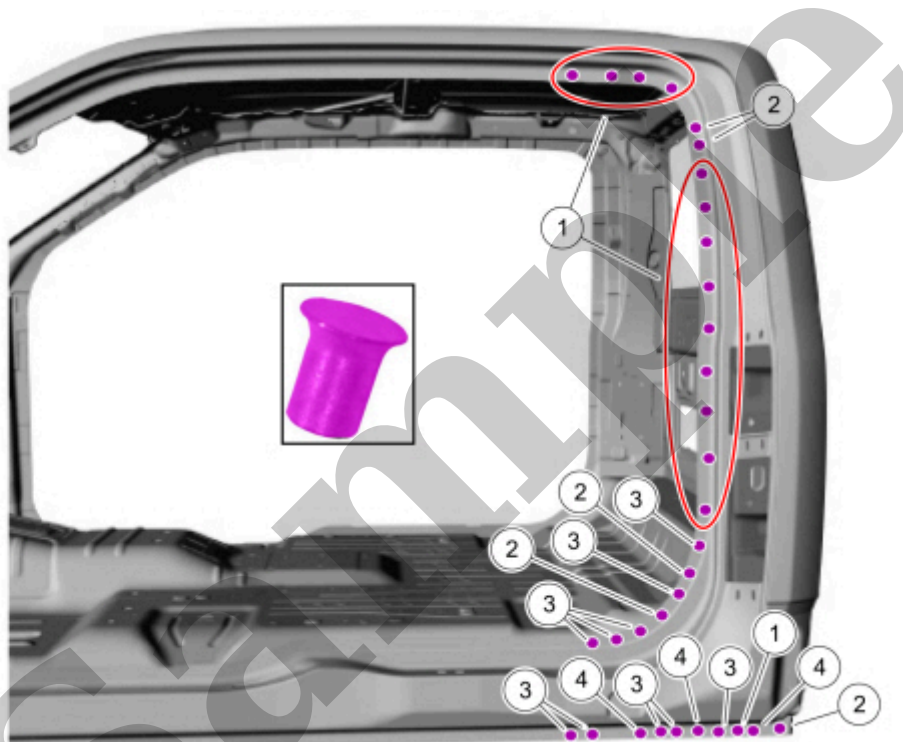

E257294

[Click here to learn about symbols, color coding, and icons used in this manual.](#)

Regular Cab

24. NOTE

SPR (self-piercing rivet) fasteners may not be placed directly over original SPR (self-piercing rivet) location. They must be placed adjacent to original location matching original quantity.

Install fasteners.

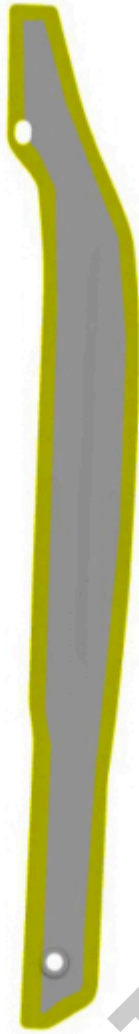
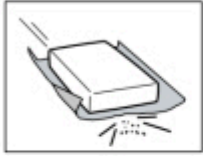

E199474

[Click here to learn about symbols, color coding, and icons used in this manual.](#)

26. Apply adhesive as indicated to the cab back filler panel mating surface.

Material : Metal Bonding Adhesive / TA-1, TA-1-B, 3M™ 08115, LORD Fusor® 108B, Henkel Teroson EP 5055