

Your Ultimate Source for OEM Repair Manuals

FactoryManuals.net is a great resource for anyone who wants to save money on repairs by doing their own work. The manuals provide detailed instructions and diagrams that make it easy to understand how to fix a vehicle.

1990 JEEP Wrangler OEM Service and Repair Workshop Manual

[Go to manual page](#)

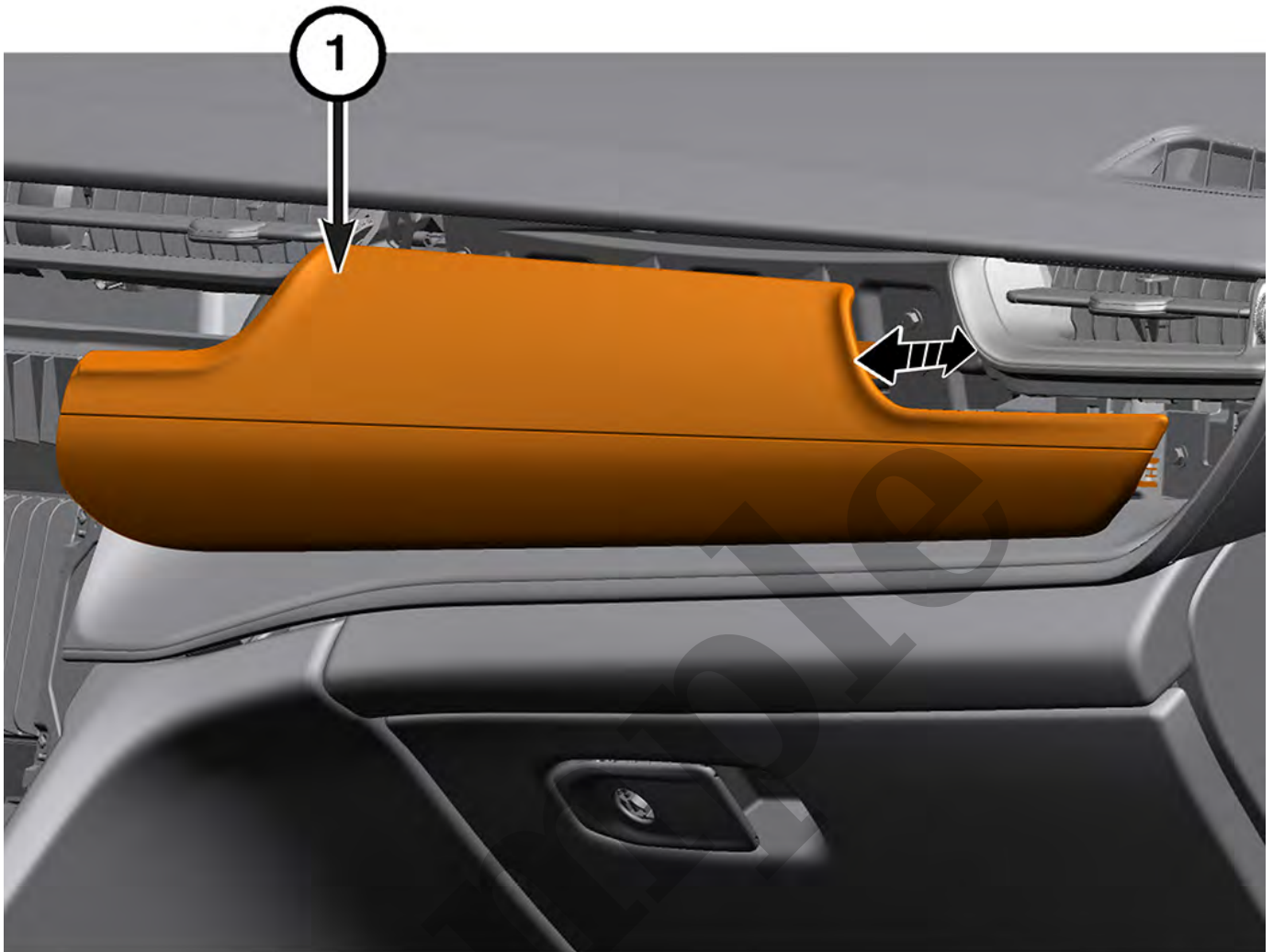

2315179015

1 - Right Instrument Panel Trim Panel

4. Using a trim stick or equivalent, remove the right instrument panel trim panel.

INSTALLATION

Follow the removal procedure in reverse for general reassembly of the components on the vehicle. The steps listed below are calling out specific procedures that should be followed during installation.

- Verify that all the retaining clips are fully seated.

Refer To List:

List 1

- [23 - Body / Instrument Panel / BEZEL, Instrument Panel, Applique / Removal and Installation](#)
- [23 - Body / Instrument Panel / BEZEL, Instrument Panel, Center / Removal and Installation](#)

4. Disconnect the wire harness connector and remove the right side silencer panel from the vehicle.

INSTALLATION

Follow the removal procedure in reverse for general reassembly of the components on the vehicle. The steps listed below are calling out specific procedures that should be followed during installation.

- Secure all fasteners.

Sample

Warning

WARNING

WARNING

To avoid serious or fatal injury on vehicles equipped with the Supplemental Restraint System (SRS), never attempt to repair the electrically conductive circuits or wiring components related to the SRS for which there is no Mopar® wiring repair kit. It is important to use ONLY the recommended splicing kit and procedure. For applicable and available Mopar® wiring repair kits, please visit the Mopar® Connection Repair Kit Web Site. Inappropriate repairs can compromise the conductivity and current carrying capacity of those critical electrical circuits, which may cause SRS components not to deploy when required, or to deploy when not required. Only minor cuts or abrasions of wire and terminal insulation where the conductive material has not been damaged, or connector insulators where the integrity of the latching and locking mechanisms have not been compromised may be repaired using appropriate methods.

WARNING

To avoid serious or fatal injury during and following any seat belt or child restraint anchor service, carefully inspect all seat belts, buckles, mounting hardware, retractors, tether straps, and anchors for proper installation, operation, or damage. Replace any belt that is cut, frayed, or torn. Straighten any belt that is twisted. Tighten any loose fasteners. Replace any belt that has a damaged or ineffective buckle or retractor. Replace any belt that has a bent or damaged latch plate or anchor plate. Replace any child restraint anchor or the unit to which the anchor is integral that has been bent or damaged. Never attempt to repair a seat belt or child restraint component. Always replace damaged or ineffective seat belt and child restraint components with the correct, new and unused replacement parts listed in the Mopar® Parts Catalog. Failure to follow these instructions may result in possible serious or fatal injury.

WARNING

To avoid serious or fatal injury on vehicles equipped with side curtain airbags, disable the Supplemental Restraint System (SRS) before attempting any Occupant Restraint Controller (ORC) diagnosis or service. The

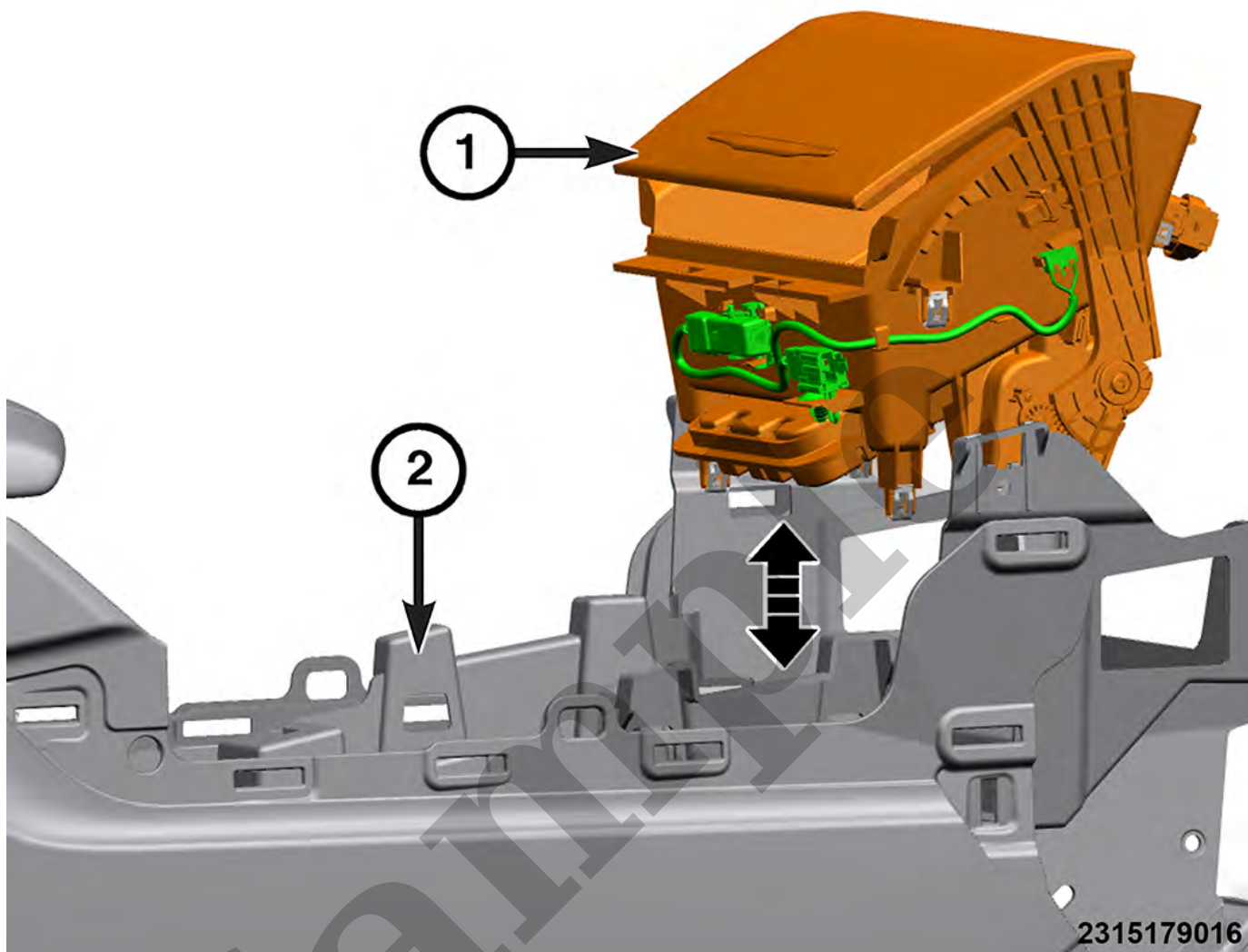

1 - Storage Bin

2 - Floor Console

3. Lift up slightly on the storage bin enough to disengage the retaining clips.
4. Disconnect the wire harness connectors and remove from the floor console.

INSTALLATION

Follow the removal procedure in reverse for general reassembly of the components on the vehicle. The steps listed below are calling out specific procedures that should be followed during installation.

- Verify the retaining clips are fully seated into the floor console when installing the storage bin.

Refer To List:

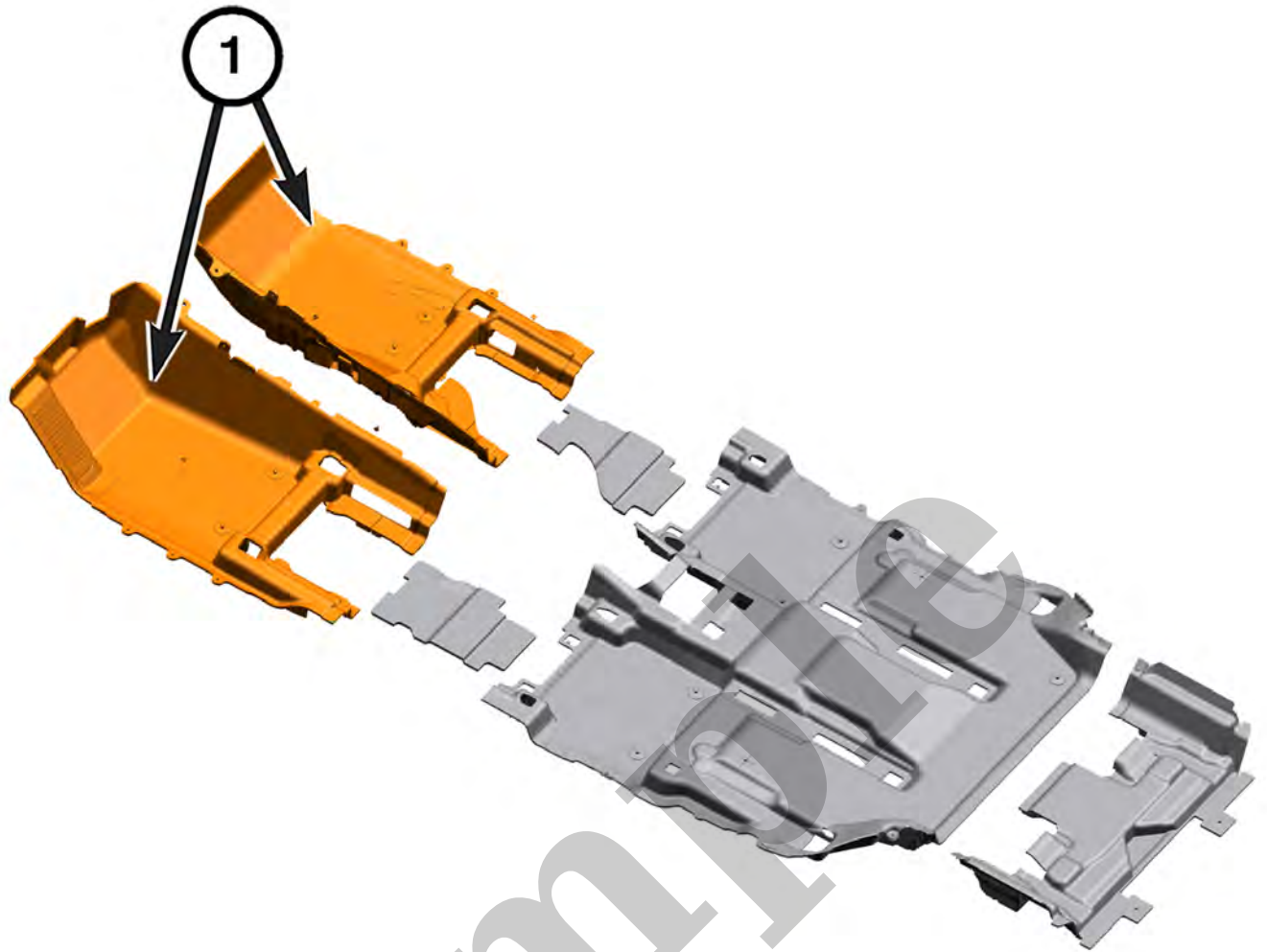

2316167838

1 - Front Floor Carpet

10. Remove the left front and right front floor carpet from the vehicle.

Caution

CAUTION

CAUTION

Do not attempt to remove interior trim panels or moldings without first removing the necessary adjacent trim panels or moldings. To avoid damaging the trim panels, ensure that all the fasteners are removed or disengaged before attempting to remove interior trim panels or moldings. Trim panels are somewhat flexible but can be damaged if handled improperly.

6. Disconnect the wire harness connector and remove the cupholder bezel from the rear floor console.

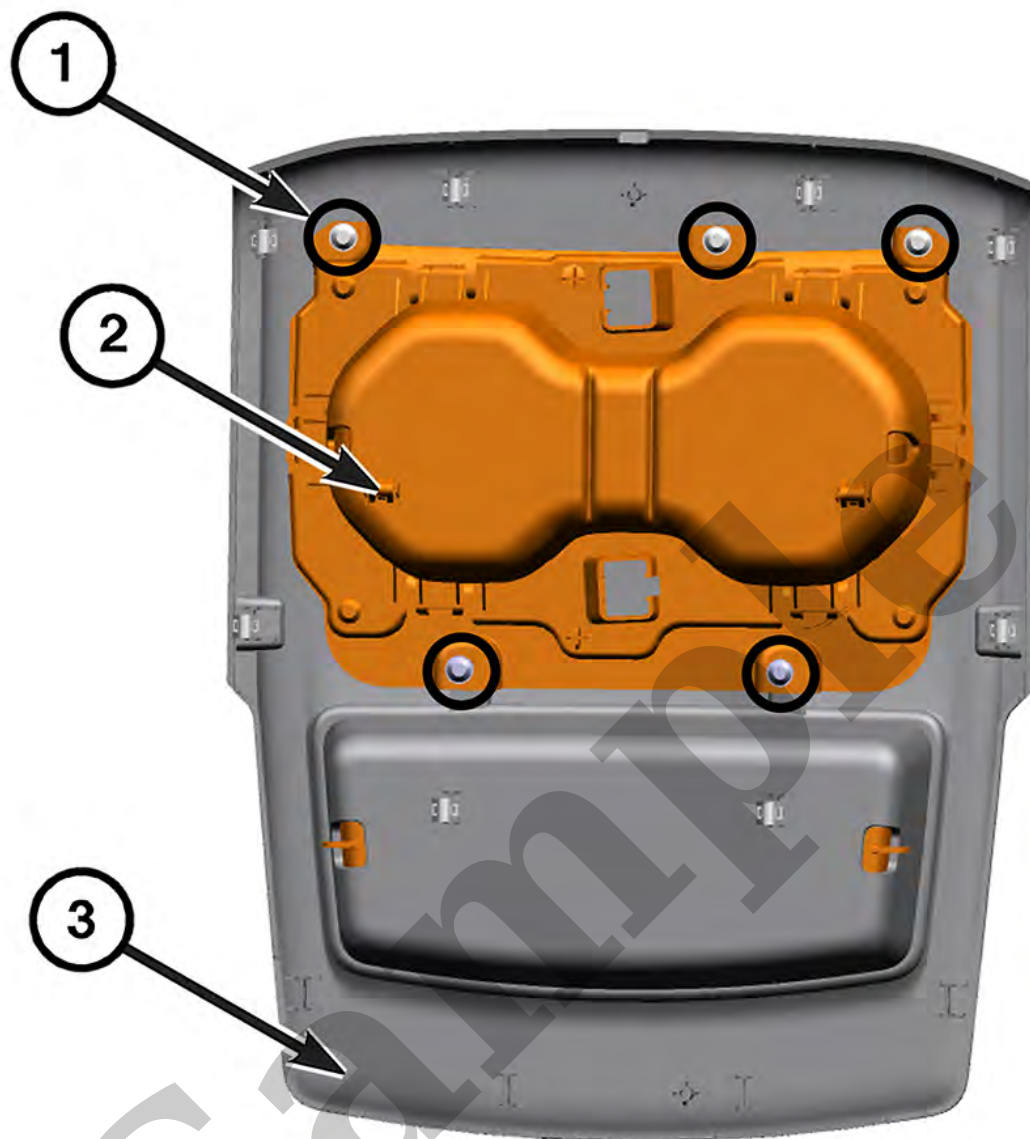

2316188803

1 - Fasteners

2 - Cupholder

3 - Cupholder Bezel

7. Remove the fasteners and separate the cupholder from the cupholder bezel.

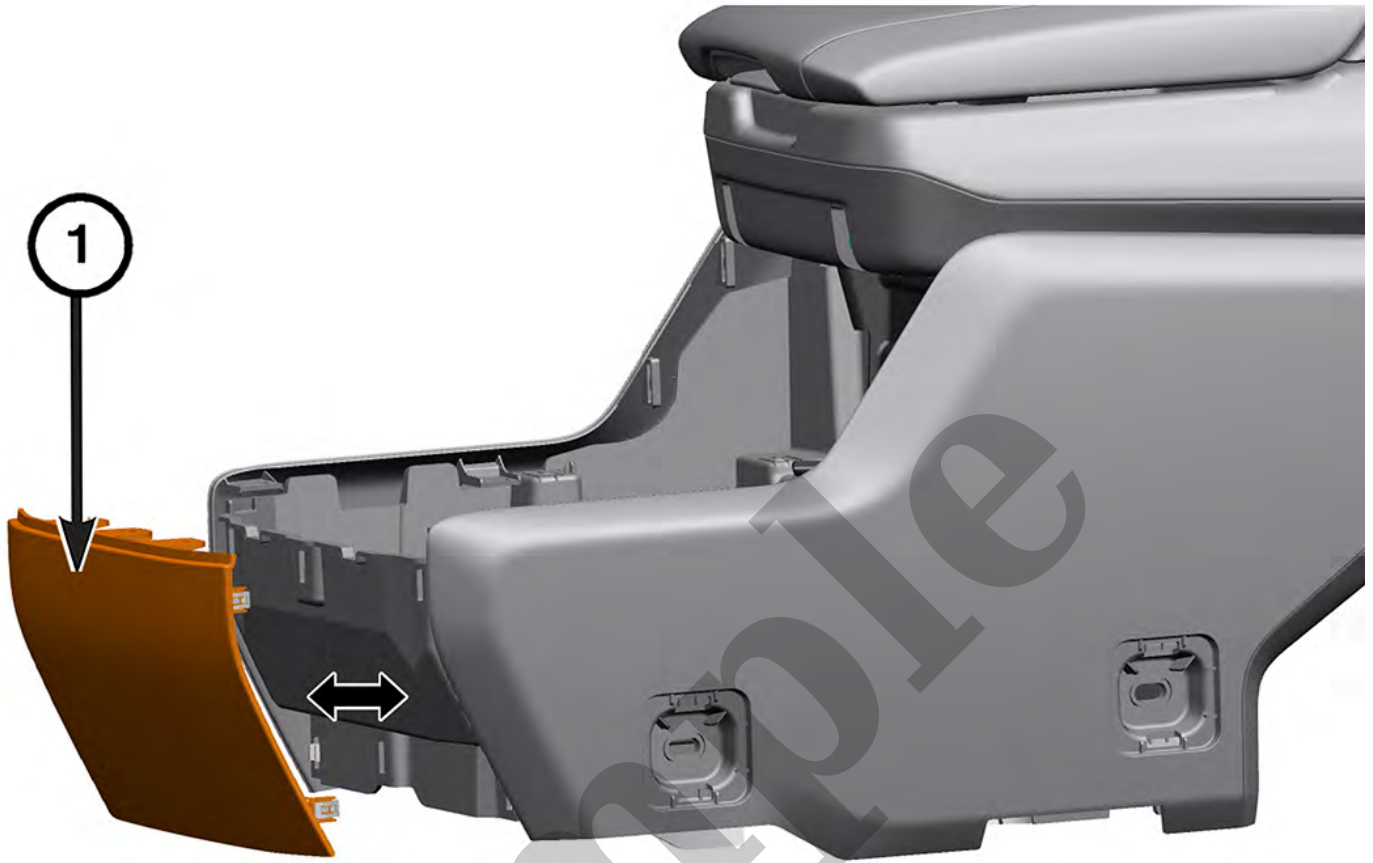

2316188809

1 - Rear Floor Console Front Trim Panel

12. Using a trim stick or equivalent, remove the rear floor console front trim panel.

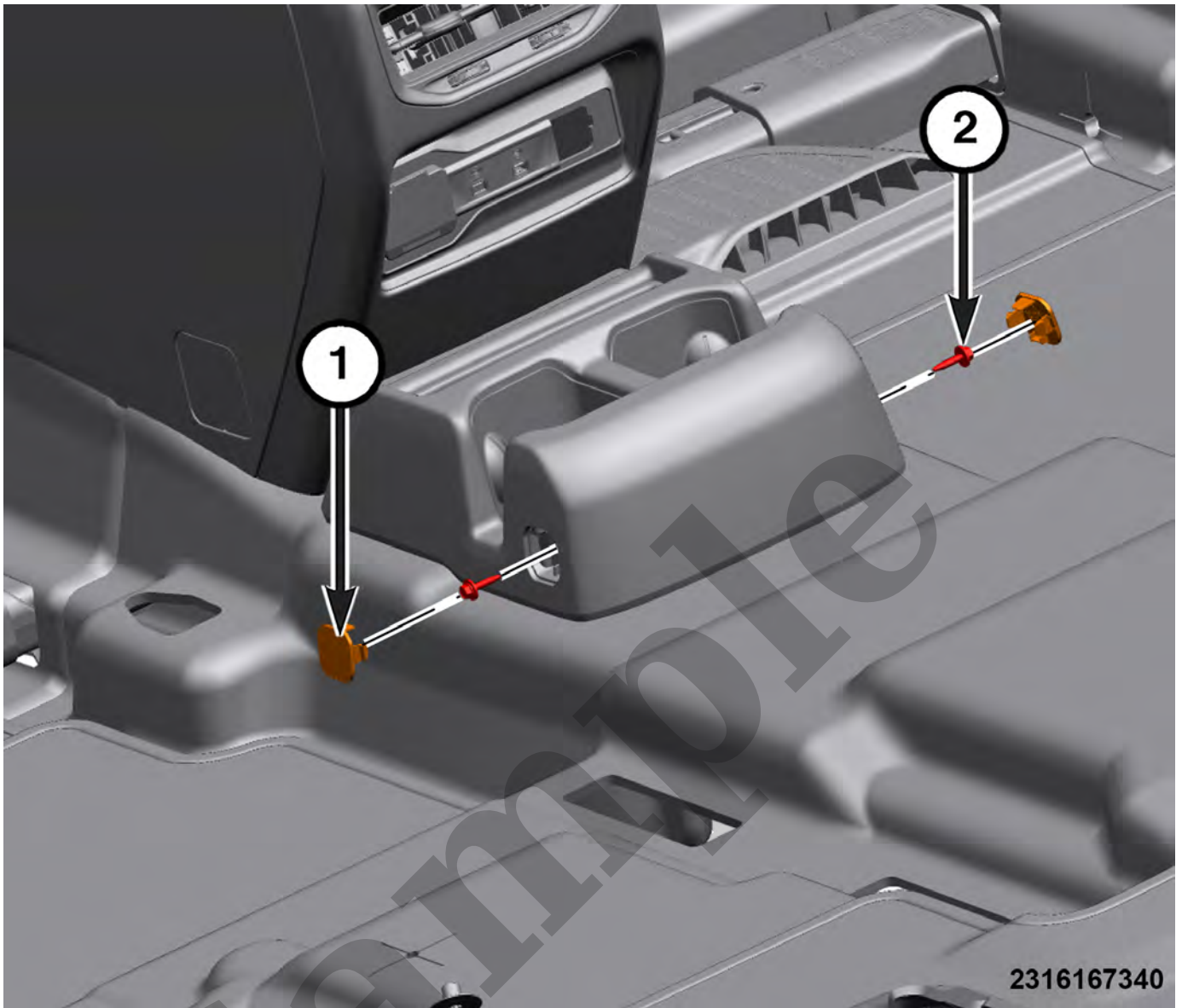

1 - Fastener Cover

2 - Fastener

3. If equipped, remove the fastener covers and remove the fasteners from the rear cup holder.