

Your Ultimate Source for OEM Repair Manuals

FactoryManuals.net is a great resource for anyone who wants to save money on repairs by doing their own work. The manuals provide detailed instructions and diagrams that make it easy to understand how to fix a vehicle.

1989 JEEP Wagoneer OEM Service and Repair Workshop Manual

[Go to manual page](#)

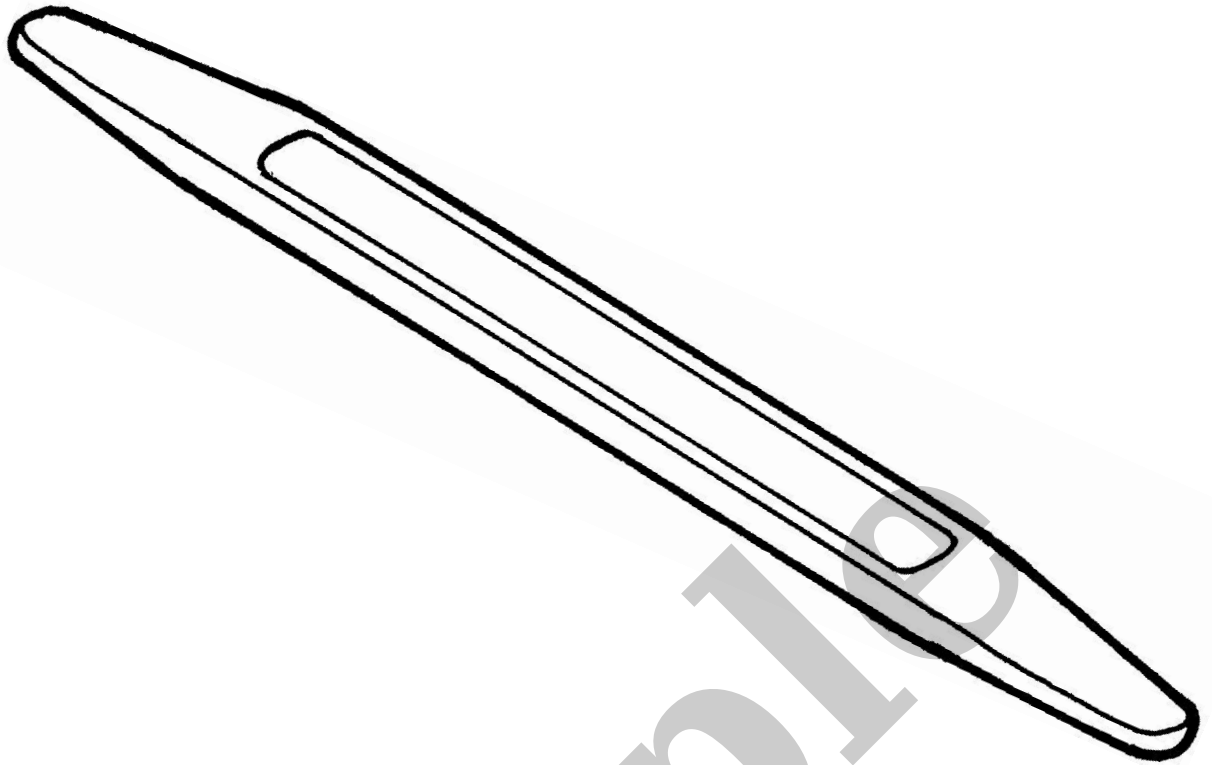

or equivalent, release the clips.

NOTE

Reaching up inside the wheel well may aid in releasing the clips.

Follow the removal procedure in reverse for general reassembly of the components on the vehicle. The steps listed below are calling out specific procedures that should be followed during installation.

- Position the mirror cover back onto the mirror assembly and insert the rearview mirror cover retaining tabs into the slots.
- Seat the mirror cover clips fully.

Sample

2 - Outside Rearview Mirror Bolt
3 - Wire Harness Support Clips
4 - Wire Harness Connectors
5 - Outside Rearview Mirror

REMOVAL

1. Remove the upper door trim panel ([Refer to Body/Door - Front/PANEL, Door Trim/Removal and Installation](#)).
2. Disconnect the wire harness connectors.
3. Release the wire harness support clips and separate the harness.
4. Remove the outside rearview mirror bolt.
5. Remove the outside rearview mirror nuts.

2 - Fender
3 - Clip Fasteners

REMOVAL

1. Remove the wheelhouse splash shield ([Refer to Body/Exterior/SHIELD, Splash, Front Wheelhouse/Removal and Installation](#)).
2. Reach behind the inside of the fender and squeeze the wings of the clip fasteners together using an 8 or 9 mm socket or pliers to release the molding from fender.
3. Repeat the above clip fastener removal procedure, and remove the remaining clip fasteners one at a time.
4. Remove the front wheel opening molding.

INSTALLATION

Follow the removal procedure in reverse for general reassembly of the components on the vehicle. The steps listed below are calling out specific procedures that should be followed during installation.

- Align the fasteners on the molding to the appropriate holes on the fender and with the use of hand pressure seat the clip fasteners fully.

REMOVAL

1. Remove the rear door carrier plate ([Refer to Body/Door - Rear/PLATE, Carrier/Removal and Installation](#)).
2. Use trim tool

Remover, Trim

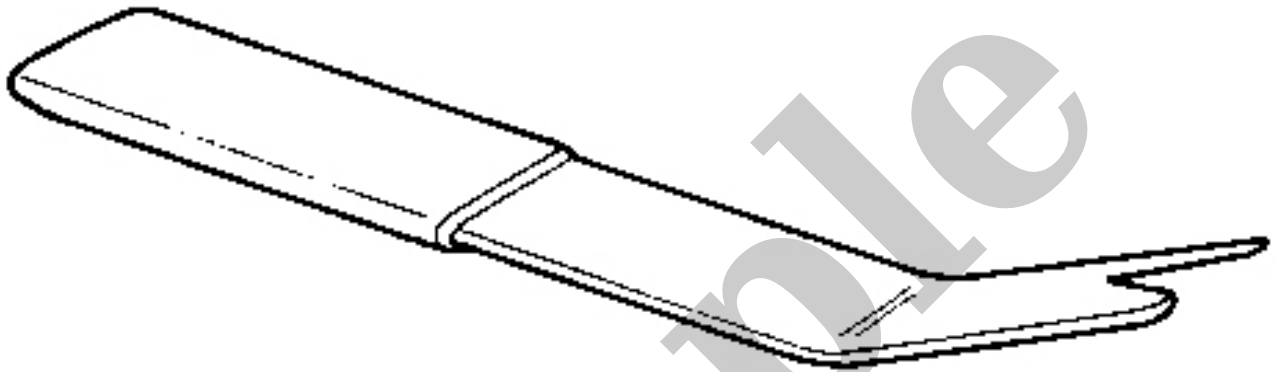

, or equivalent to release the clip fasteners.

3. If necessary, from inside the door release the spring retainers for the molding and remove the molding.

INSTALLATION

Follow the removal procedure in reverse for general reassembly of the components on the vehicle. The steps listed below are calling out specific procedures that should be followed during installation.

- Clean the painted surface with Mopar® Super Kleen solvent, or equivalent. Wipe surface dry with lint free cloth.
- With the use of hand pressure seat the clip fasteners fully.

Side Emblem

SIDE EMBLEM

REMOVAL

1. As a guide for installation, apply a length of masking tape on the body, parallel to the top edge and to one end of the nameplate or decal being removed.

CAUTION

Do not exceed 52° C (120° F) when heating nameplates, decals or body panels. Failure to follow this caution may result in damage to the nameplates, decals or the vehicle paint finish.

2. If the temperature is below 21° C (70° F), warm the nameplate or decal with a heat lamp or heat gun.

NOTE

The exterior nameplates are attached to the body with adhesive tape.

3. Using a trim stick or equivalent, carefully remove the nameplate or decal from the body panel, as necessary.

INSTALLATION

Follow the removal procedure in reverse for general reassembly of the components on the vehicle. The steps listed below are calling out specific procedures that should be followed during installation.

- Thoroughly clean all residue from the nameplate or decal attachment areas of the body.
- Wipe the attachment areas with a clean, lint-free cloth, moistened with a 50% solution of water and alcohol and then wipe dry the areas immediately with a dry, lint-free cloth.
- If ambient temperatures are below 21° C (70° F), warm the nameplate or decal and body panel with a heat lamp or gun to assure proper adhesion.
- To ensure proper nameplate or decal adhesion, apply consistent and uniform pressure of approximately 40 p.s.i. over the entire surface of each nameplate or decal.

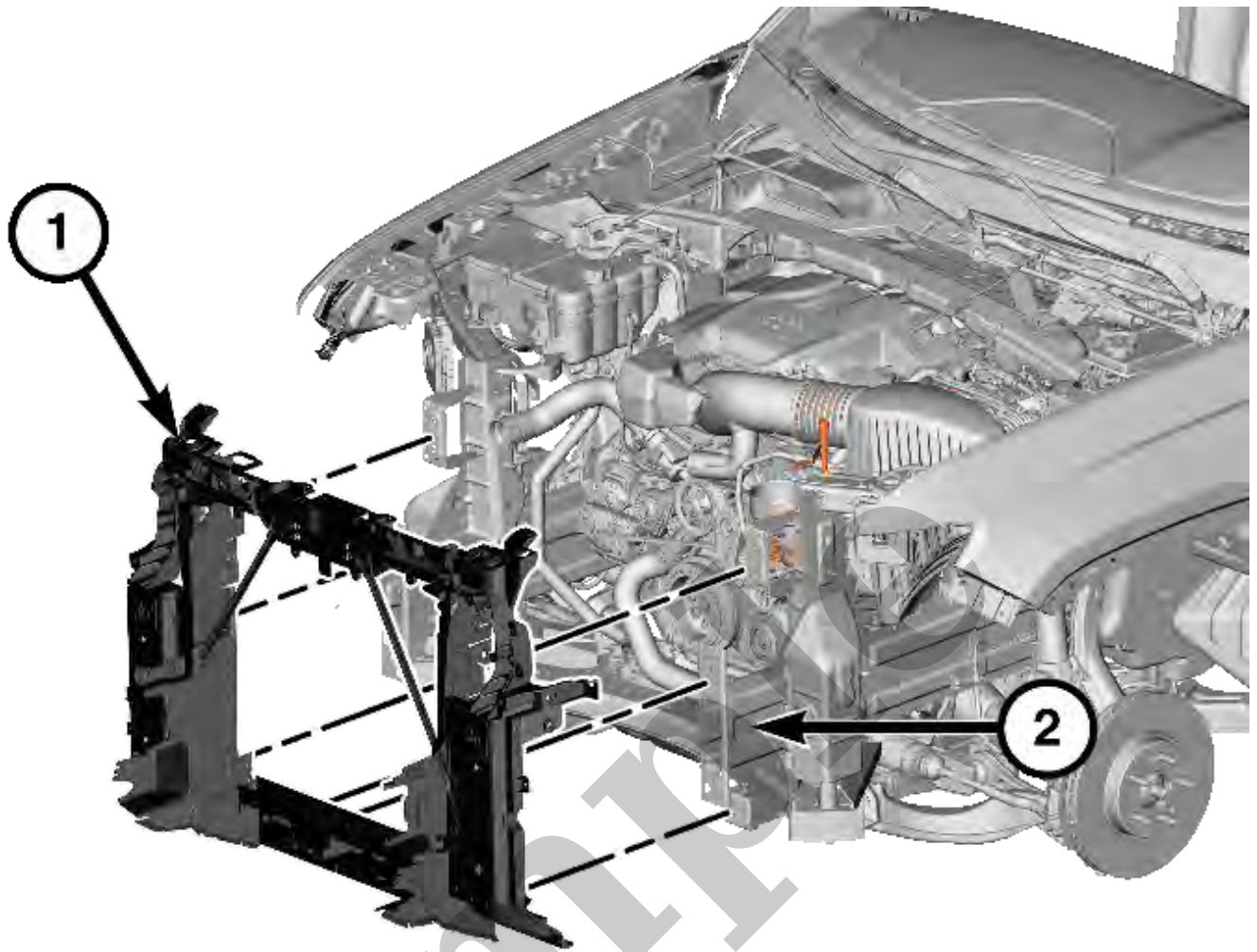

2313166484

1 - Radiator Closure Panel
2 - Front Bumper Reinforcement Mounting Bracket

12. Carefully remove the closure making sure the paint on the front edge of the fenders is protected from damage.

INSTALLATION

Follow the removal procedure in reverse for general reassembly of the components on the vehicle.

TORQUE SPECIFICATIONS - EXTERIOR

1. Using a trim stick

Trim Stick

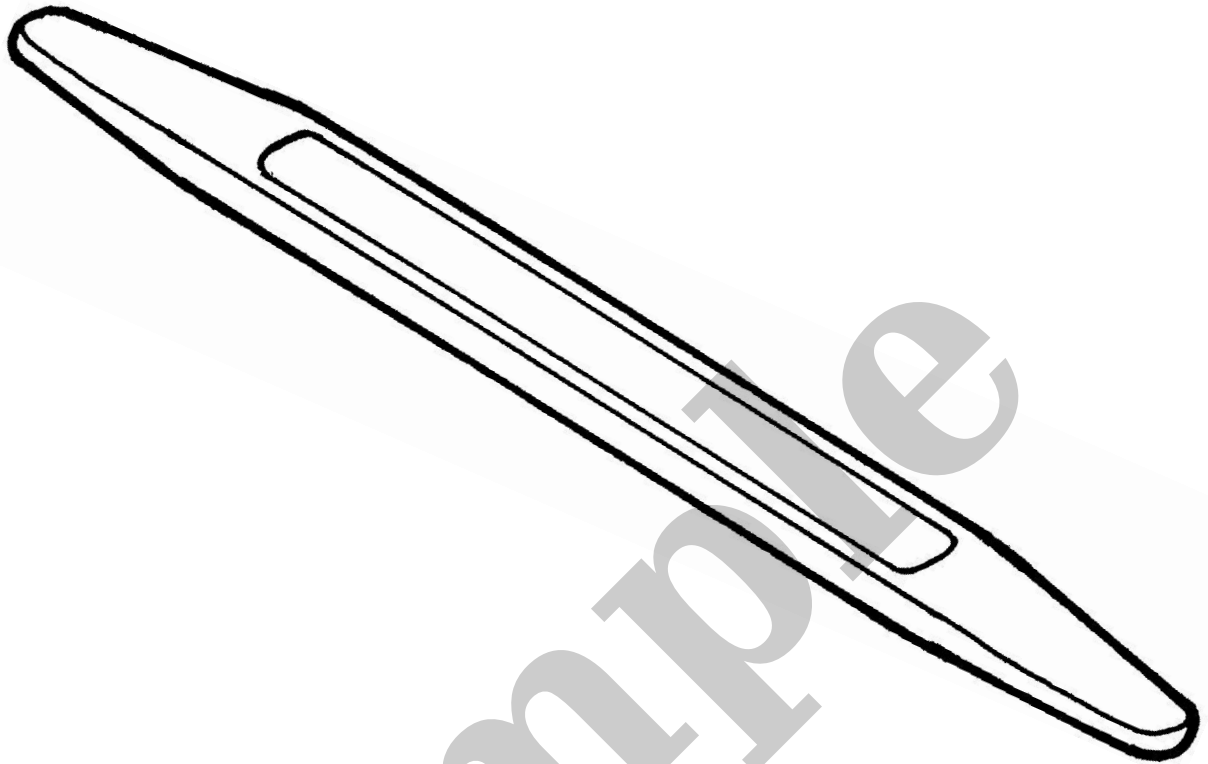

or equivalent, pry up to release the retaining clips securing the luggage rack rail cover and remove the cover.

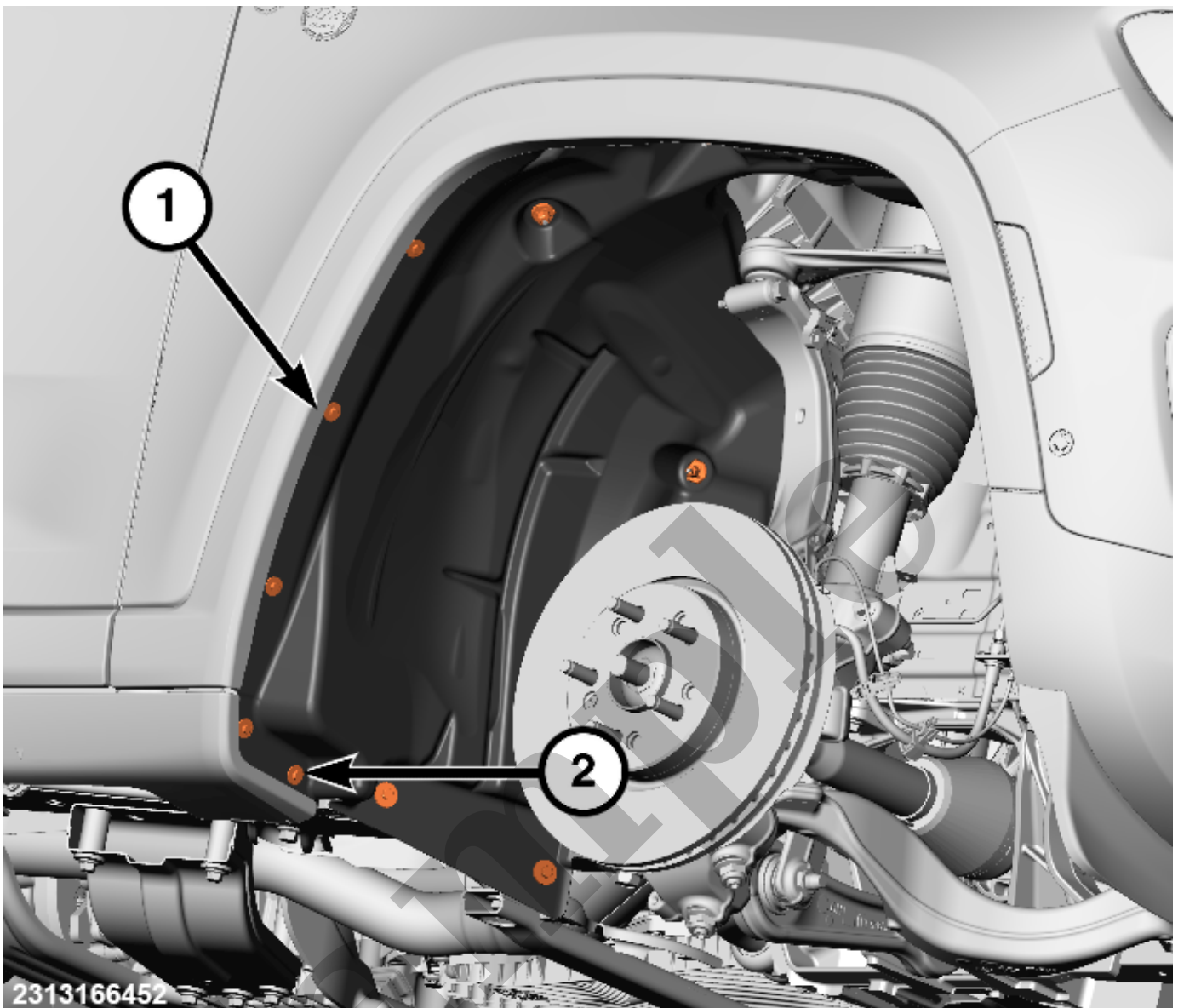

1 - Side Screws

2 - Lower Screws

3. Remove the side screws, if equipped.

4. Remove the lower screws.