

Your Ultimate Source for OEM Repair Manuals

FactoryManuals.net is a great resource for anyone who wants to save money on repairs by doing their own work. The manuals provide detailed instructions and diagrams that make it easy to understand how to fix a vehicle.

1983 JEEP Wagoneer OEM Service and Repair Workshop Manual

[Go to manual page](#)

1 - Fasteners

2 - Front Closeout Panel

1. Remove the fasteners and remove the front closeout panel.

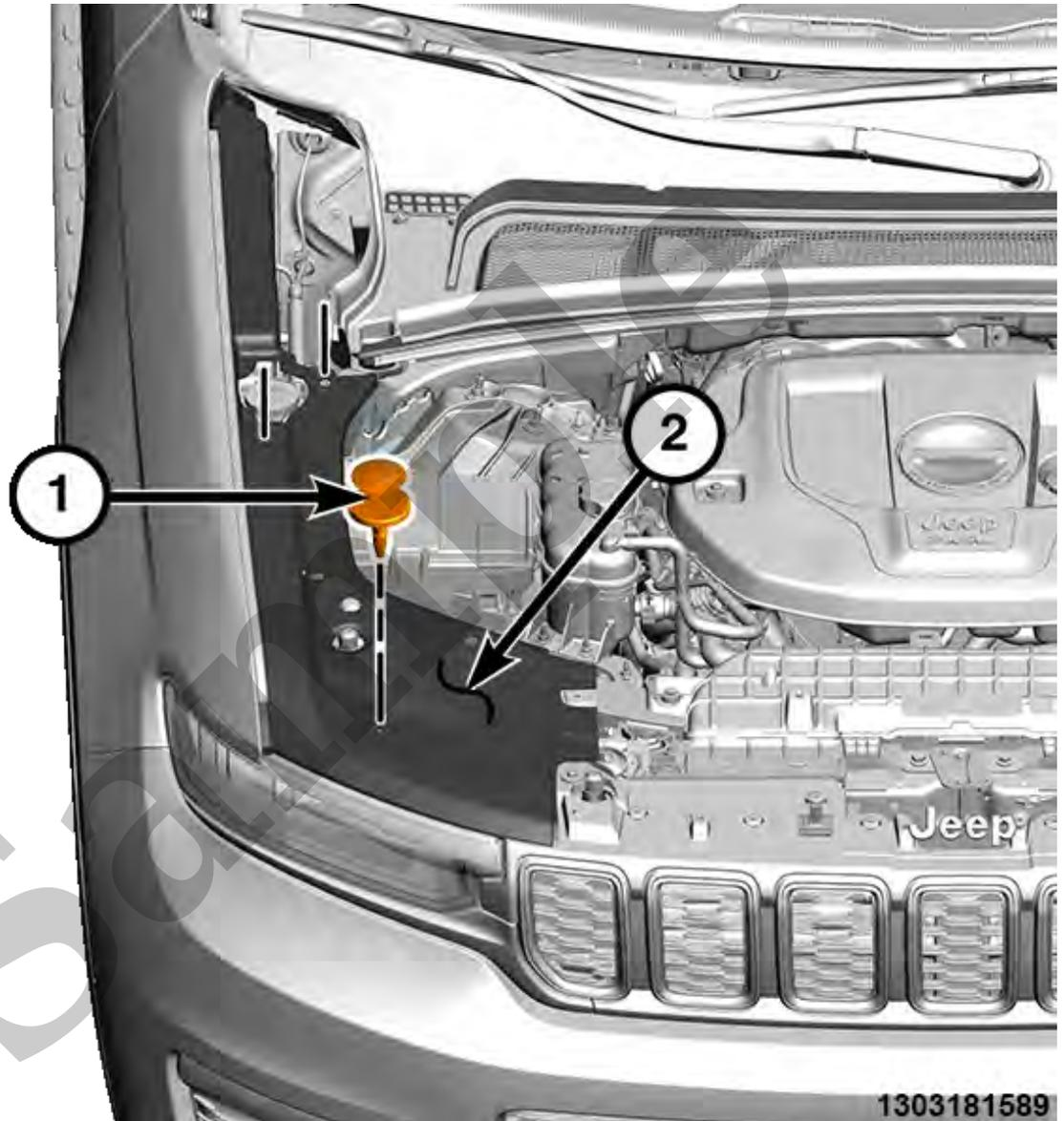

1 - Fasteners

2 - Side Closeout Panel

2. Remove the fasteners and remove the side closeout panels from both sides of the vehicle.

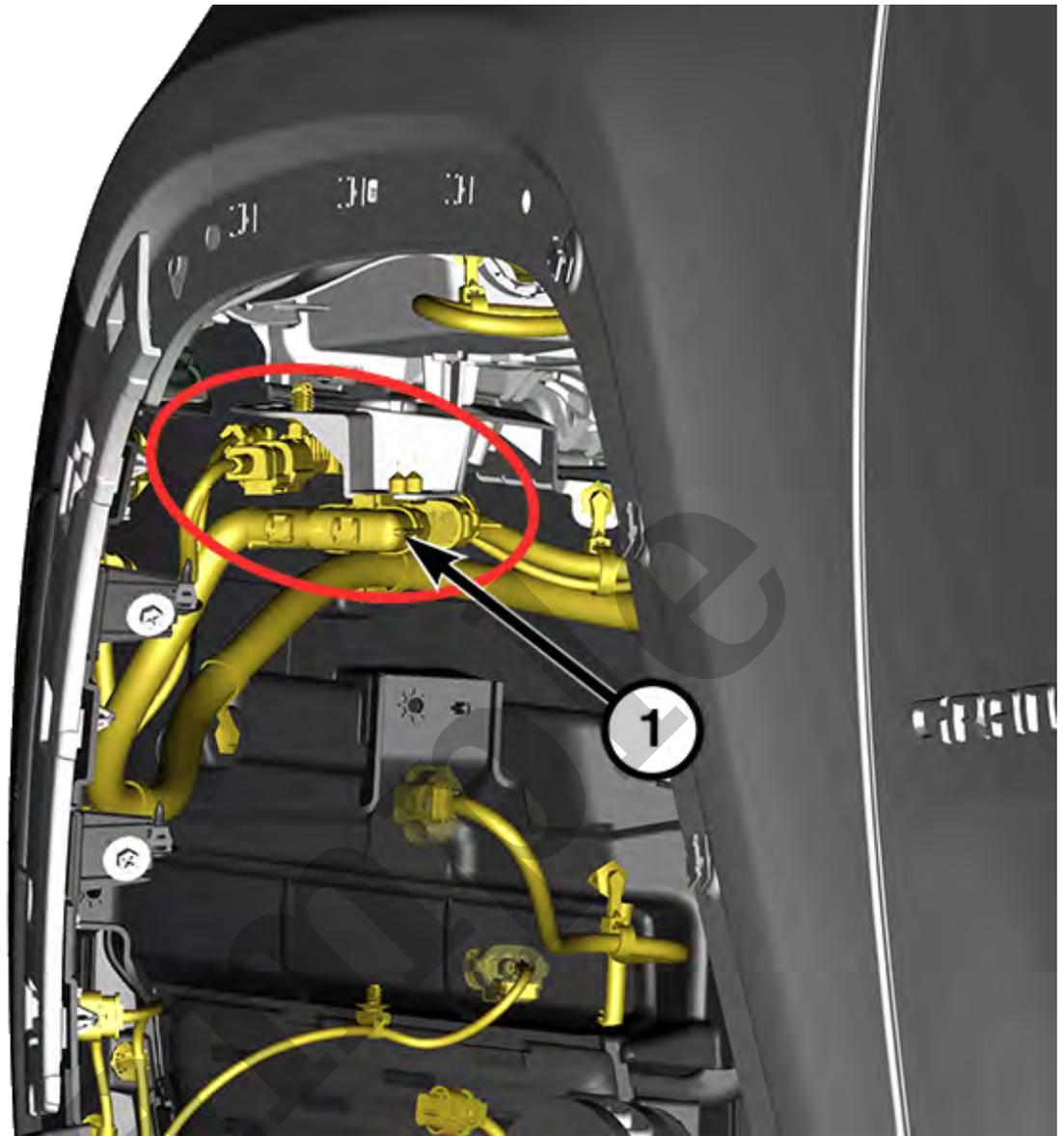

1303181595

1 - Wire Harness Connectors

7. Disconnect the wire harness connectors on both sides of the vehicle, if equipped.

Using suitable hose-pinching pliers, clamp-off the washer hose and disconnect.

- If applicable, perform **both** the Night Vision Processing Module (NVPM) calibration and the Long Range Radar Front (LRRF) calibration procedures ([Refer to Electrical/Programming and Calibration/Programming and Calibration](#)).

Sample

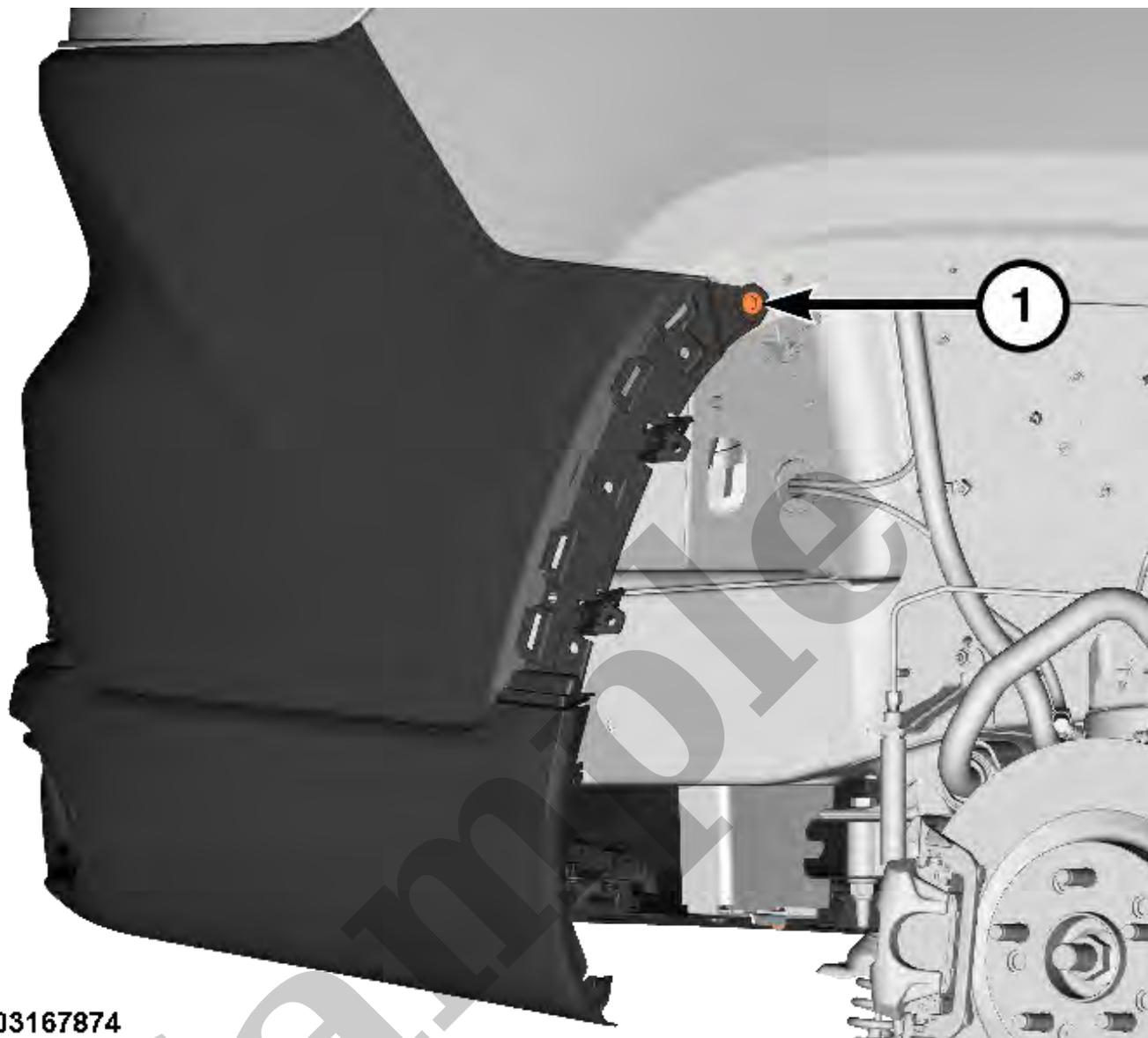

1303167874

1 - Front Fastener

6. Remove the front fasteners from each side of the rear fascia.

YOUR CURRENT VEHICLE

Front Bumper Reinforcement

FRONT BUMPER REINFORCEMENT

REMOVAL

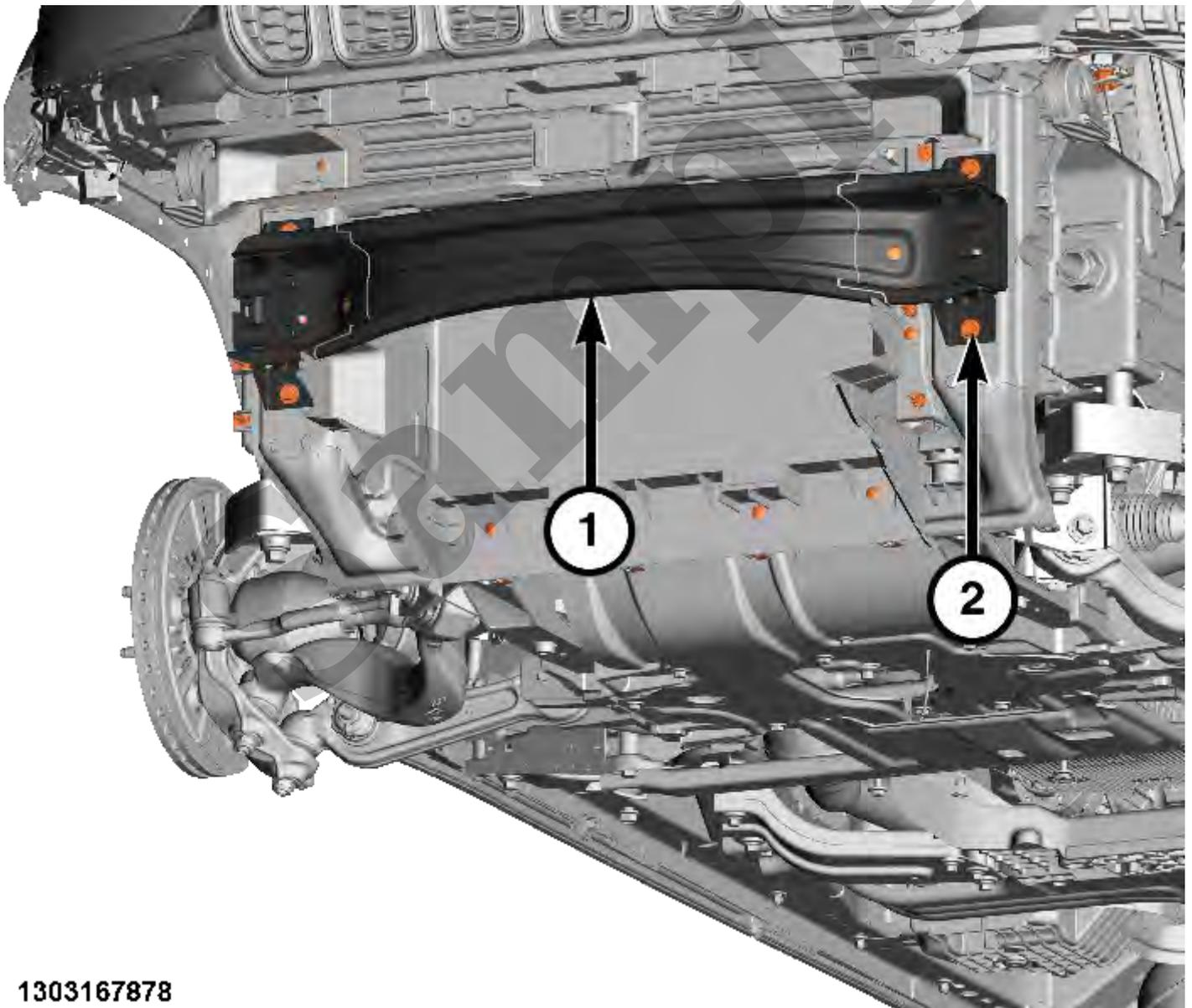

1303167878

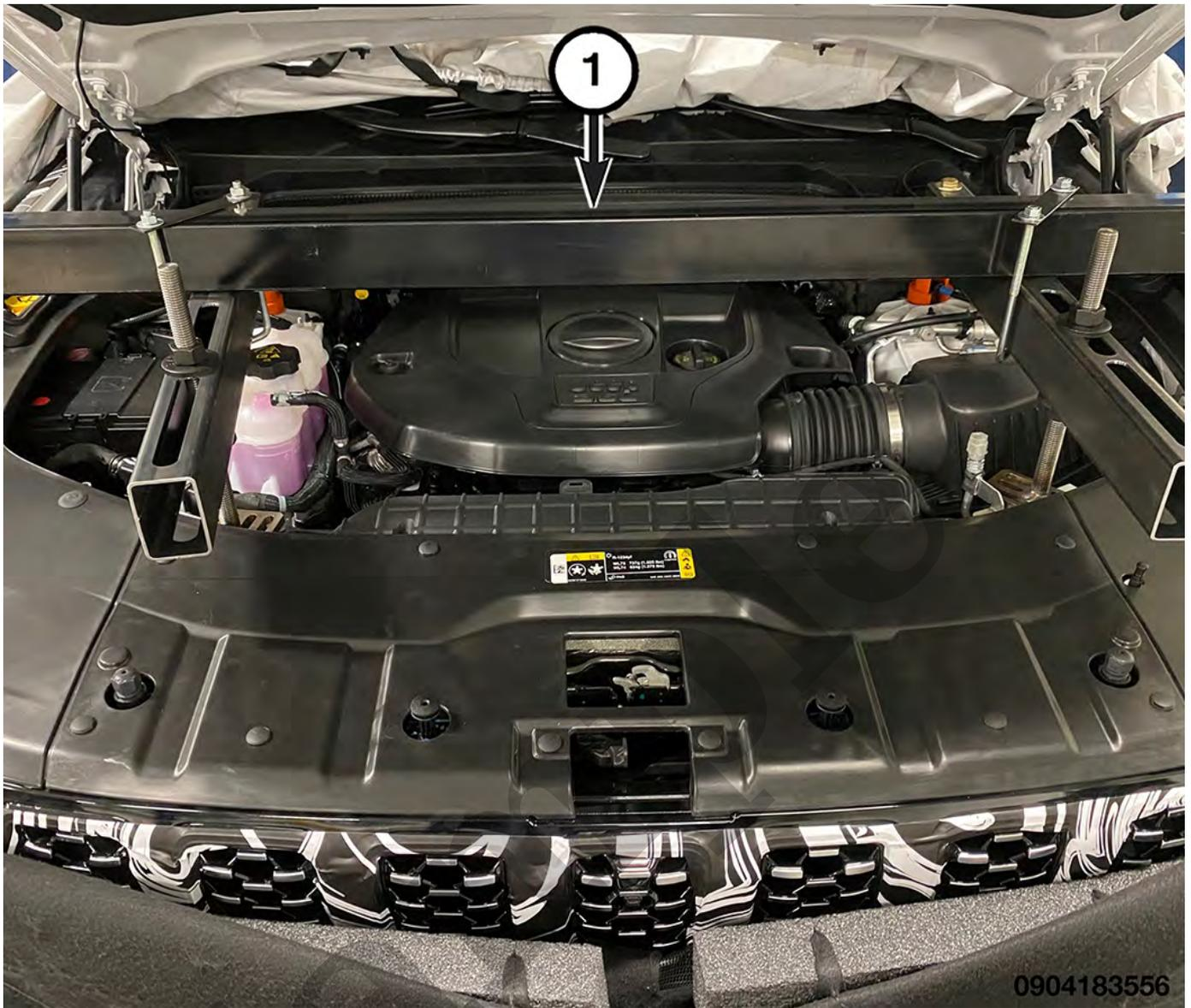

1 - Engine Support Fixture Tool 8534C-17 - Kit

3. Support the engine with the Engine Support Fixture

Fixture, Driveline Support

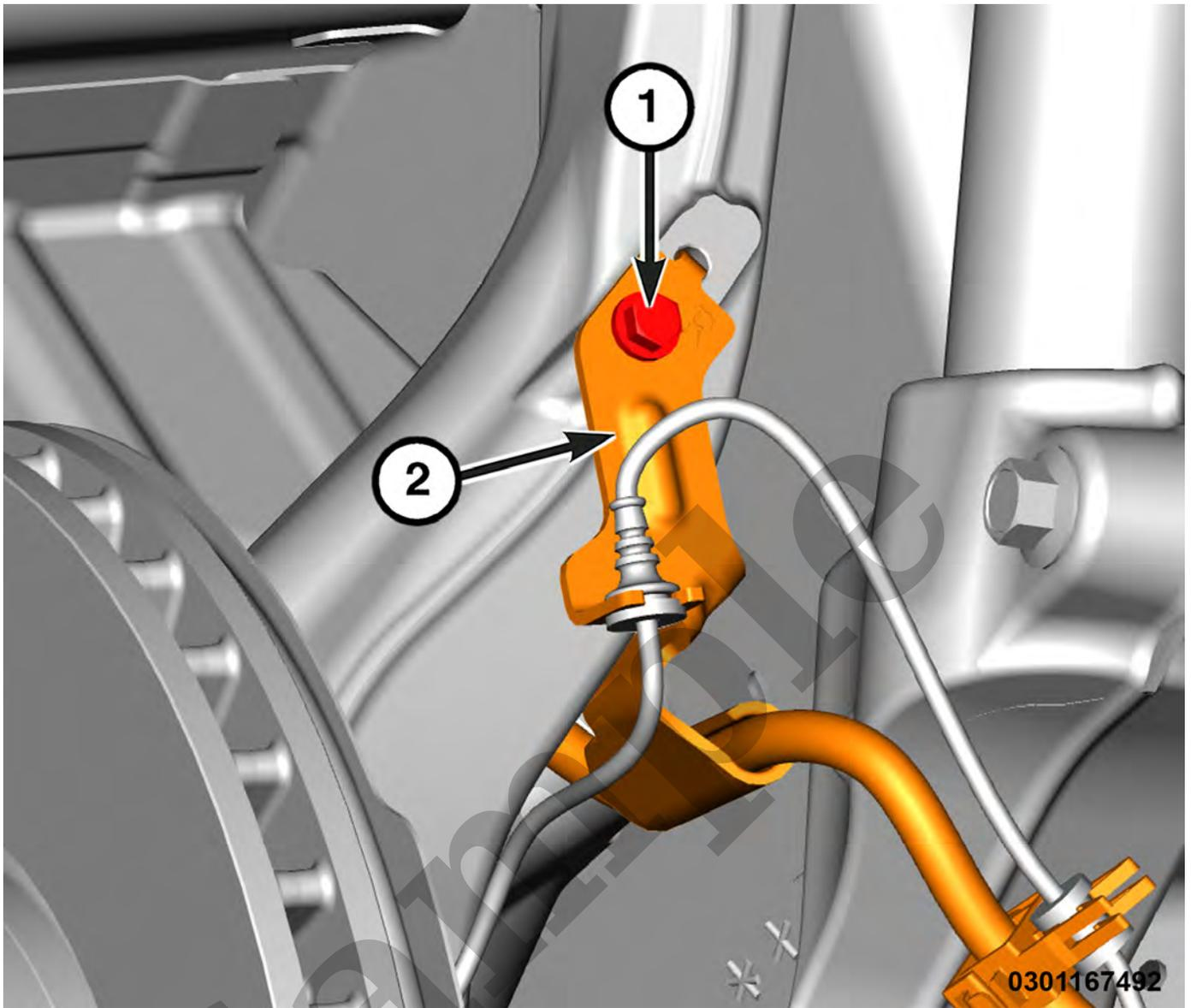

1 - Brake Line Bracket Bolt

2 - Brake Line Bracket

11. Remove the brake line bracket bolt to the steering knuckle and position aside.

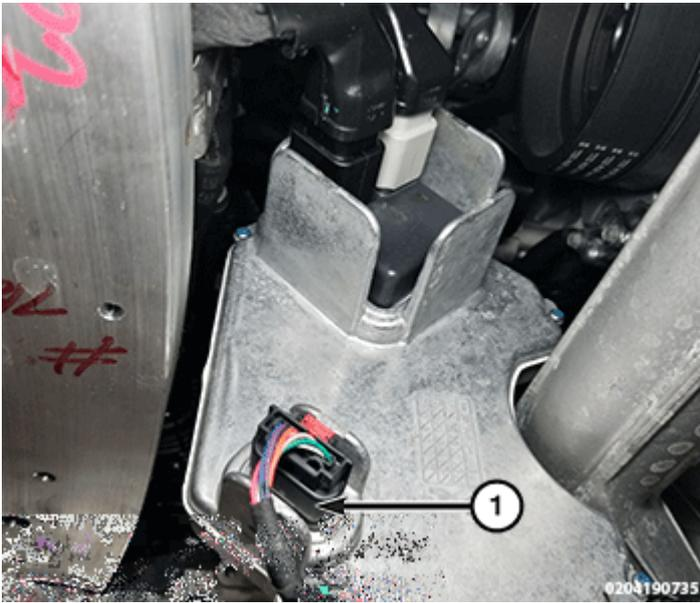

1 - Torque Sensor Wire Harness Connector

18. **DO NOT** disconnect the torque sensor wire harness connector.

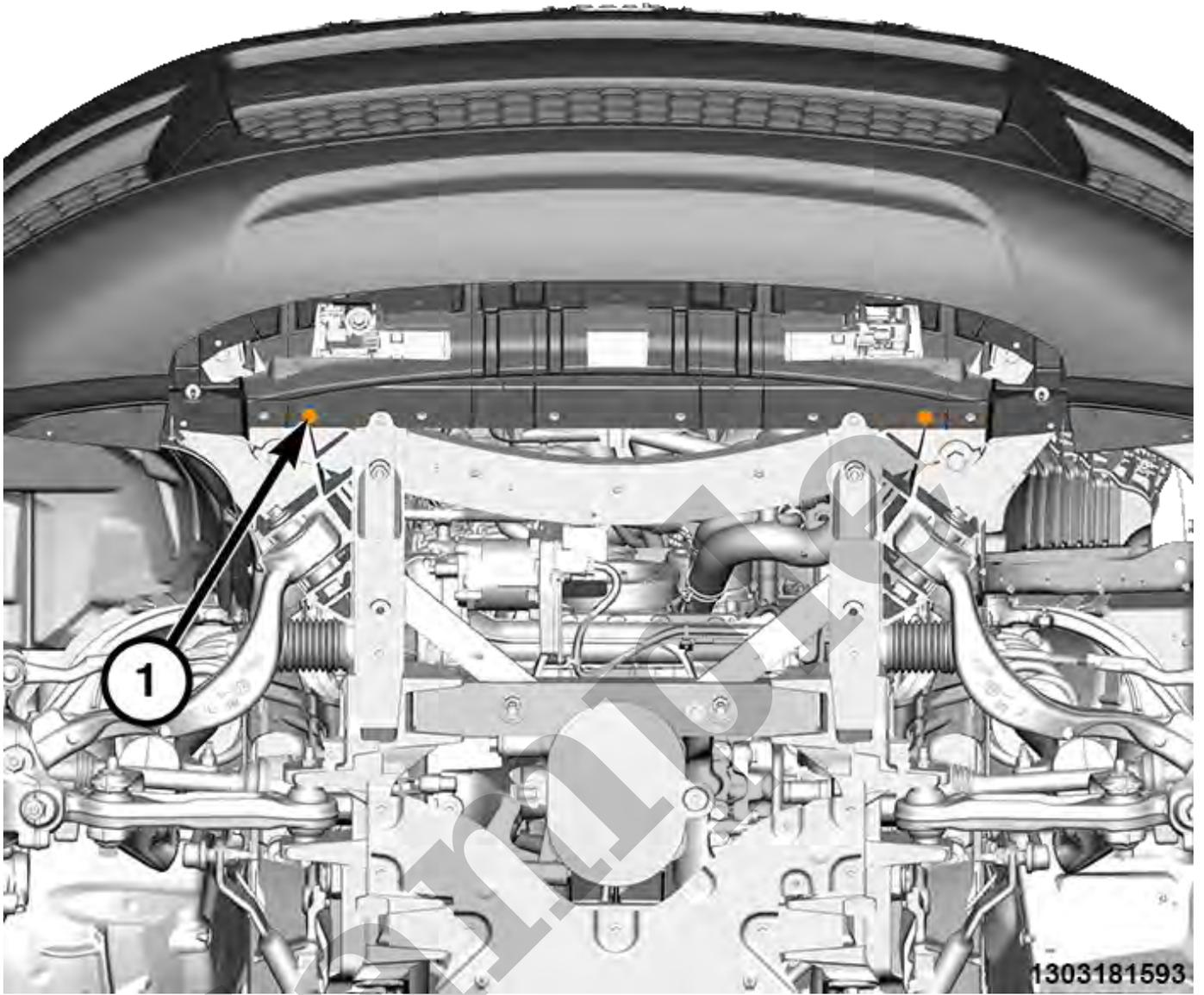

1 - Lower Front Fascia Fasteners

22. Remove the lower front fascia fasteners.