

# Your Ultimate Source for OEM Repair Manuals

FactoryManuals.net is a great resource for anyone who wants to save money on repairs by doing their own work. The manuals provide detailed instructions and diagrams that make it easy to understand how to fix a vehicle.

## 1982 VOLVO 760 OEM Service and Repair Workshop Manual

[Go to manual page](#)

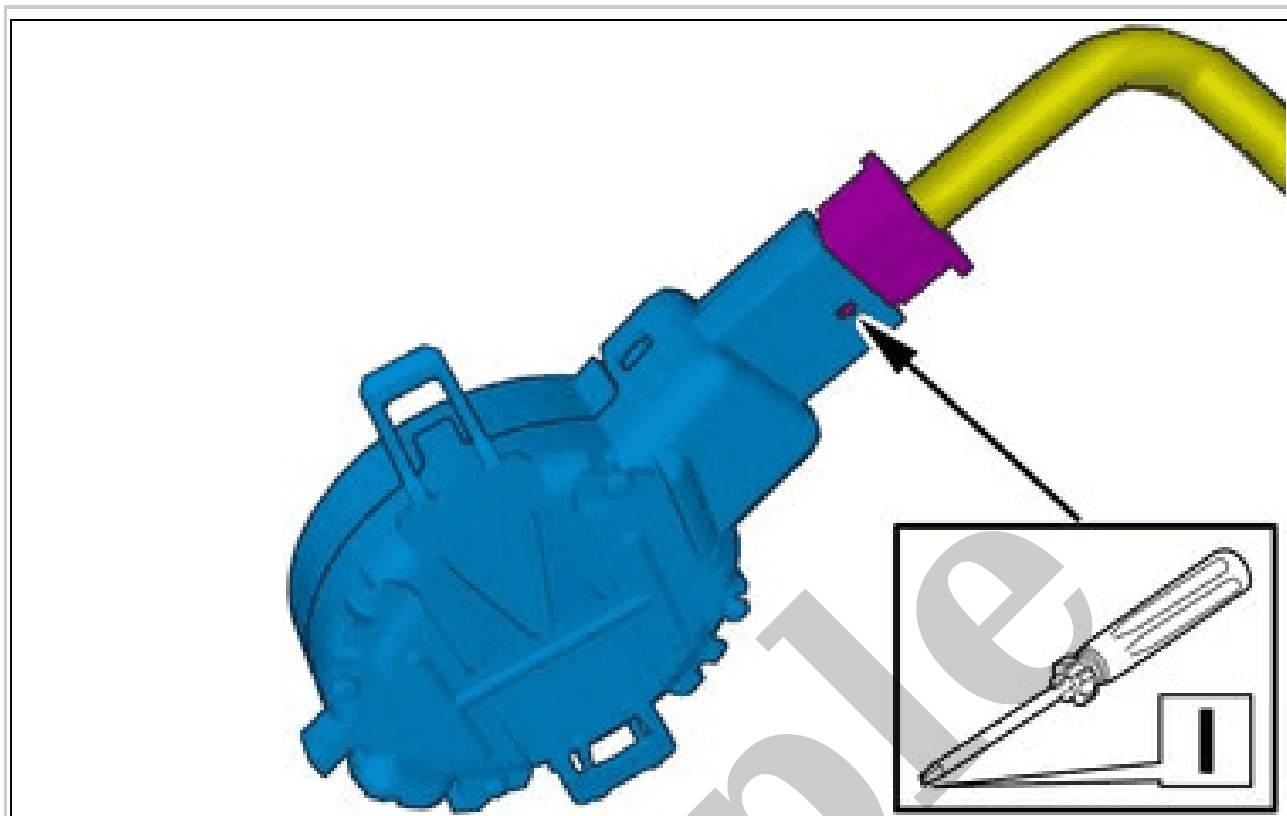

Courtesy of VOLVO CARS CORPORATION

Disconnect the connector.

**Use:** Electrician's screwdriver



Courtesy of VOLVO CARS CORPORATION

**CAUTION:** *The silicon surface must not be touched, any contamination of the surface will damage the sensor.*

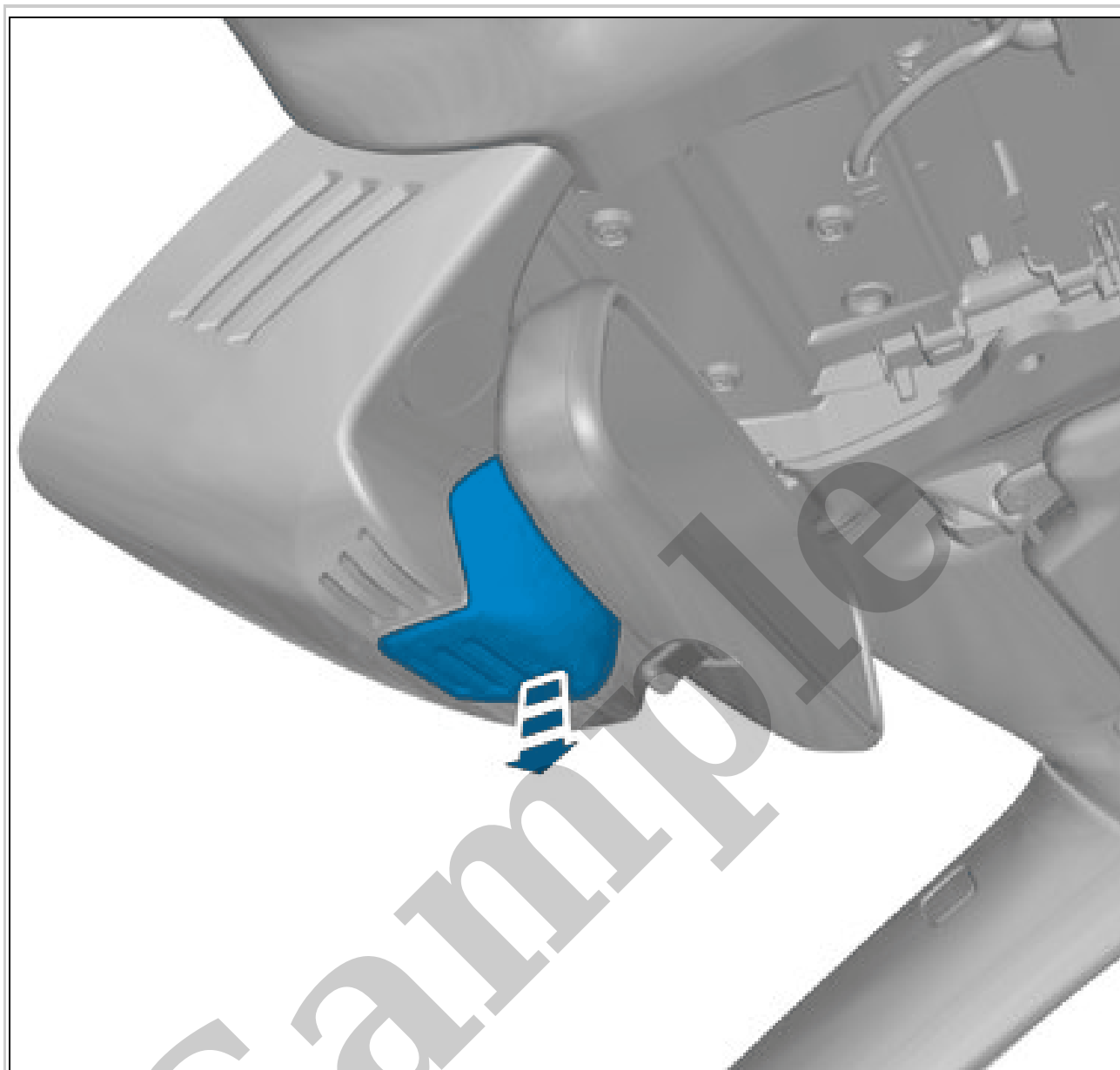

Courtesy of VOLVO CARS CORPORATION

Remove the marked part.

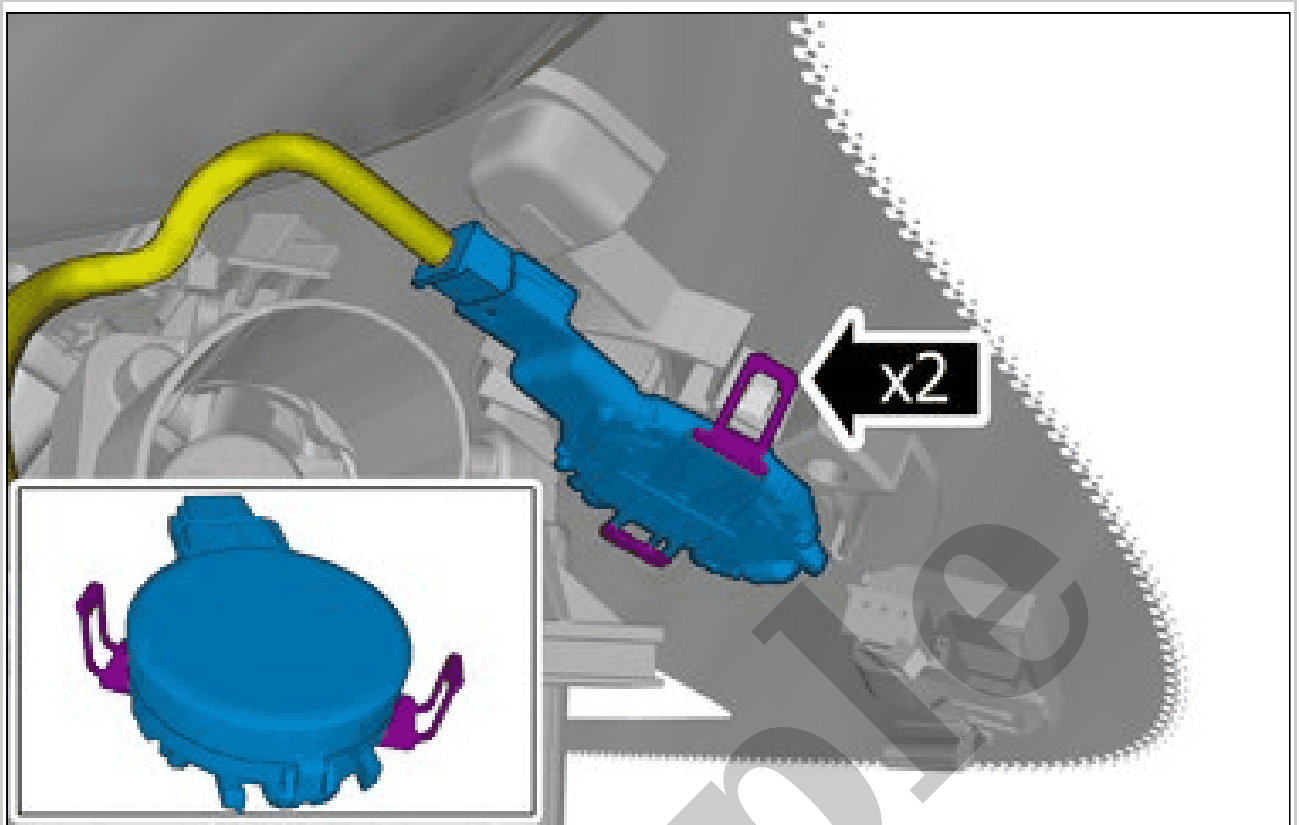

Courtesy of VOLVO CARS CORPORATION

Loosen the clips.

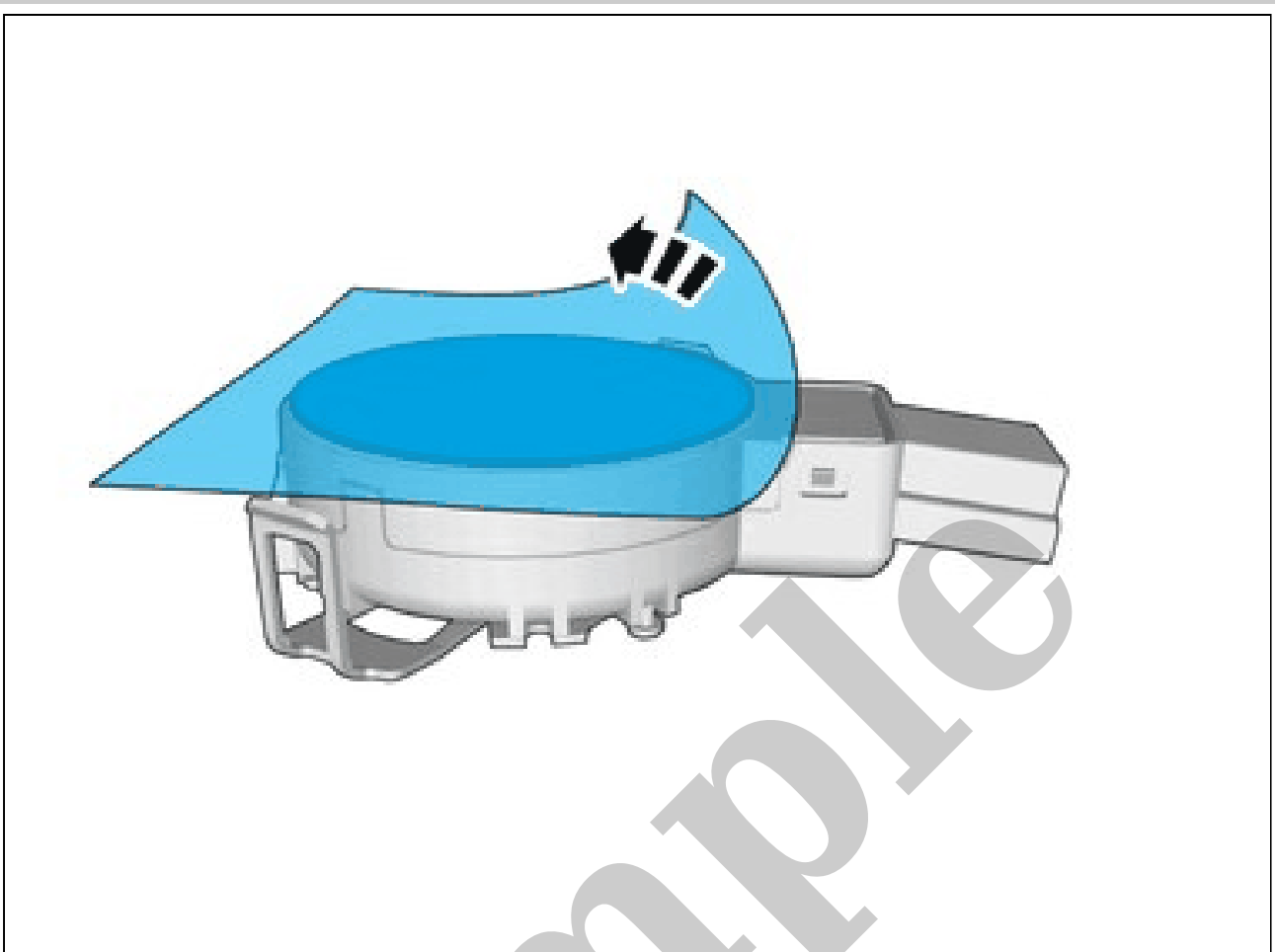

Courtesy of VOLVO CARS CORPORATION

Remove the protective film.

Sample

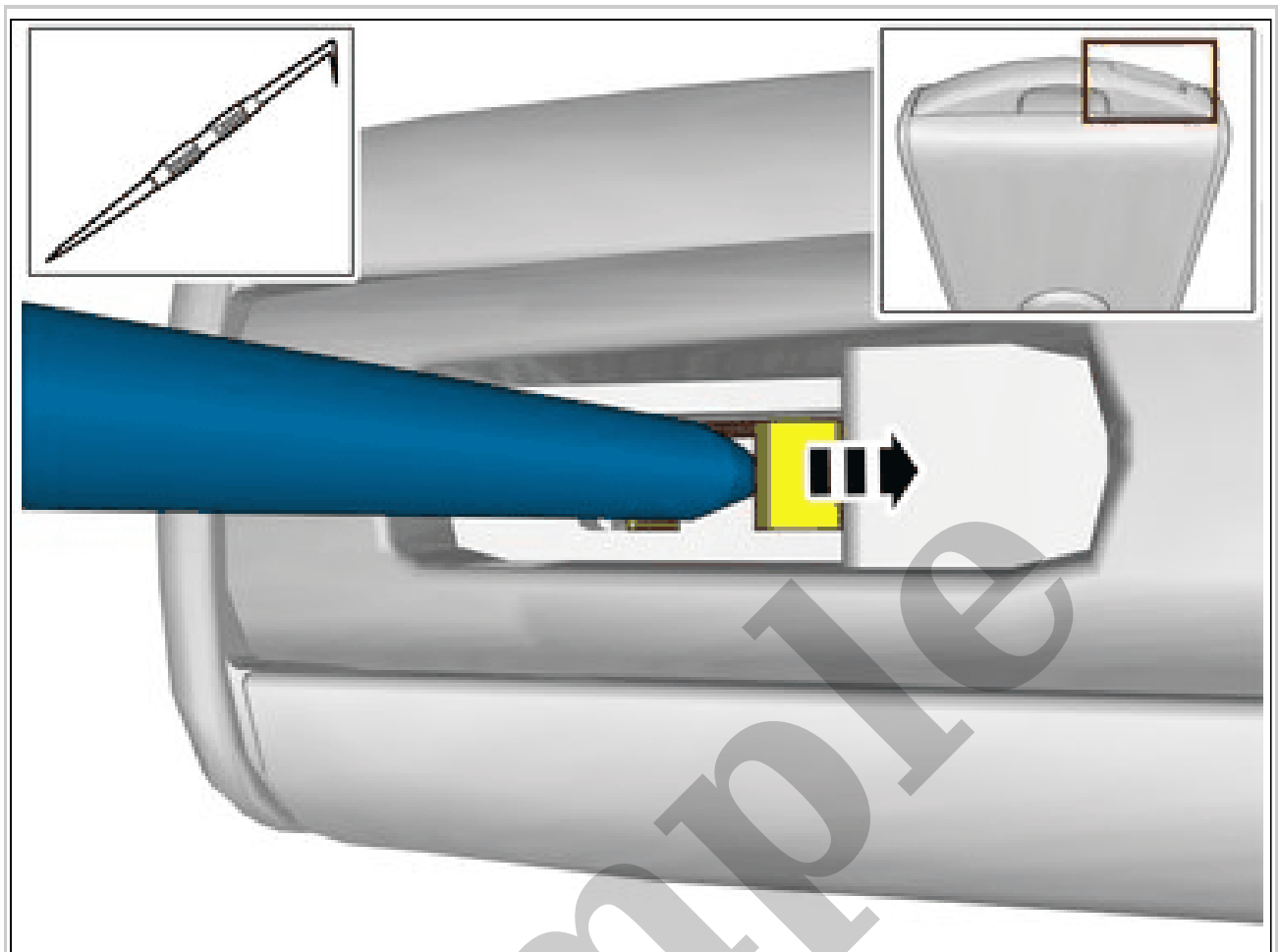

Courtesy of VOLVO CARS CORPORATION

Release the lock.  
Hold it down.

Remove casing bumper rear. Refer to: COVER BUMPER REAR

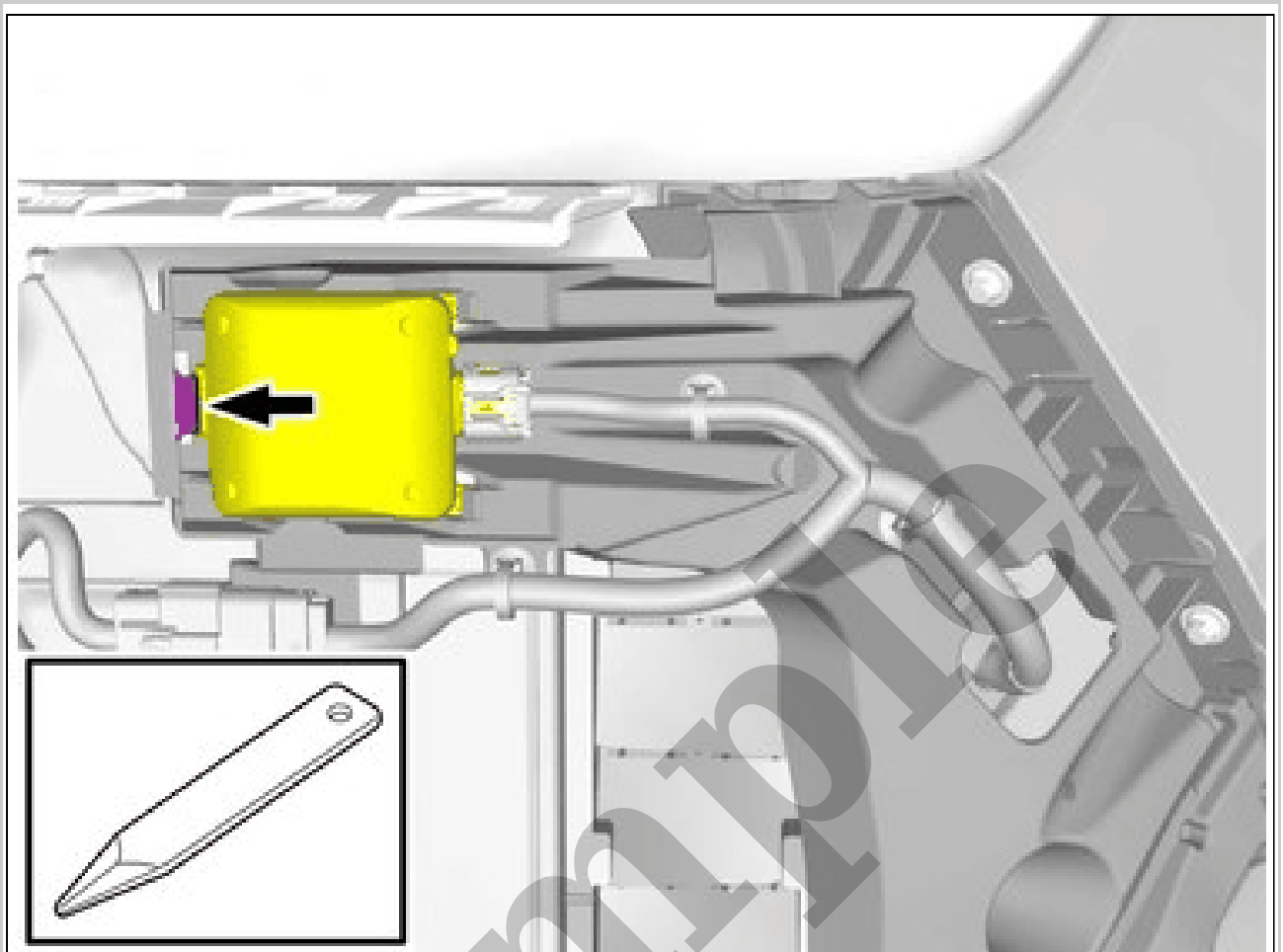

Courtesy of VOLVO CARS CORPORATION

Depress the locking device.  
Fold marked part aside.



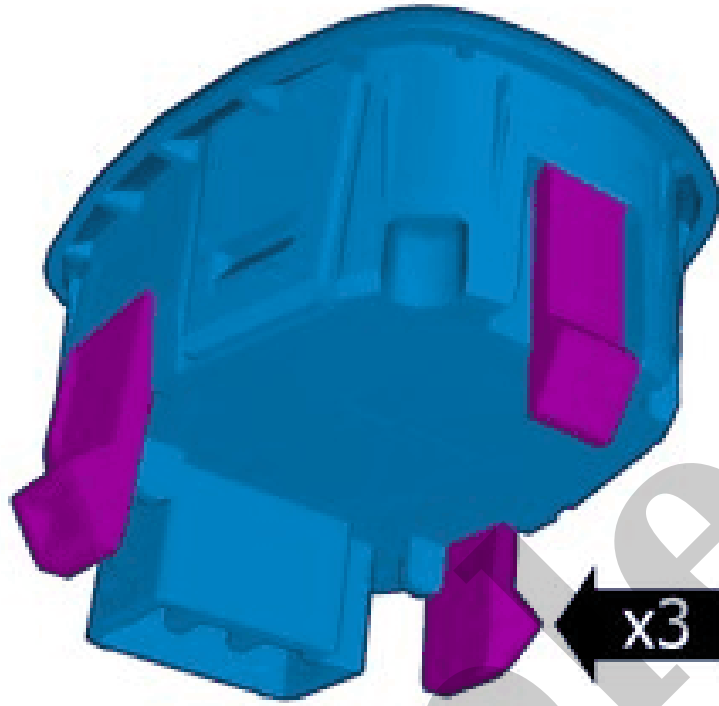

Courtesy of VOLVO CARS CORPORATION

Sample

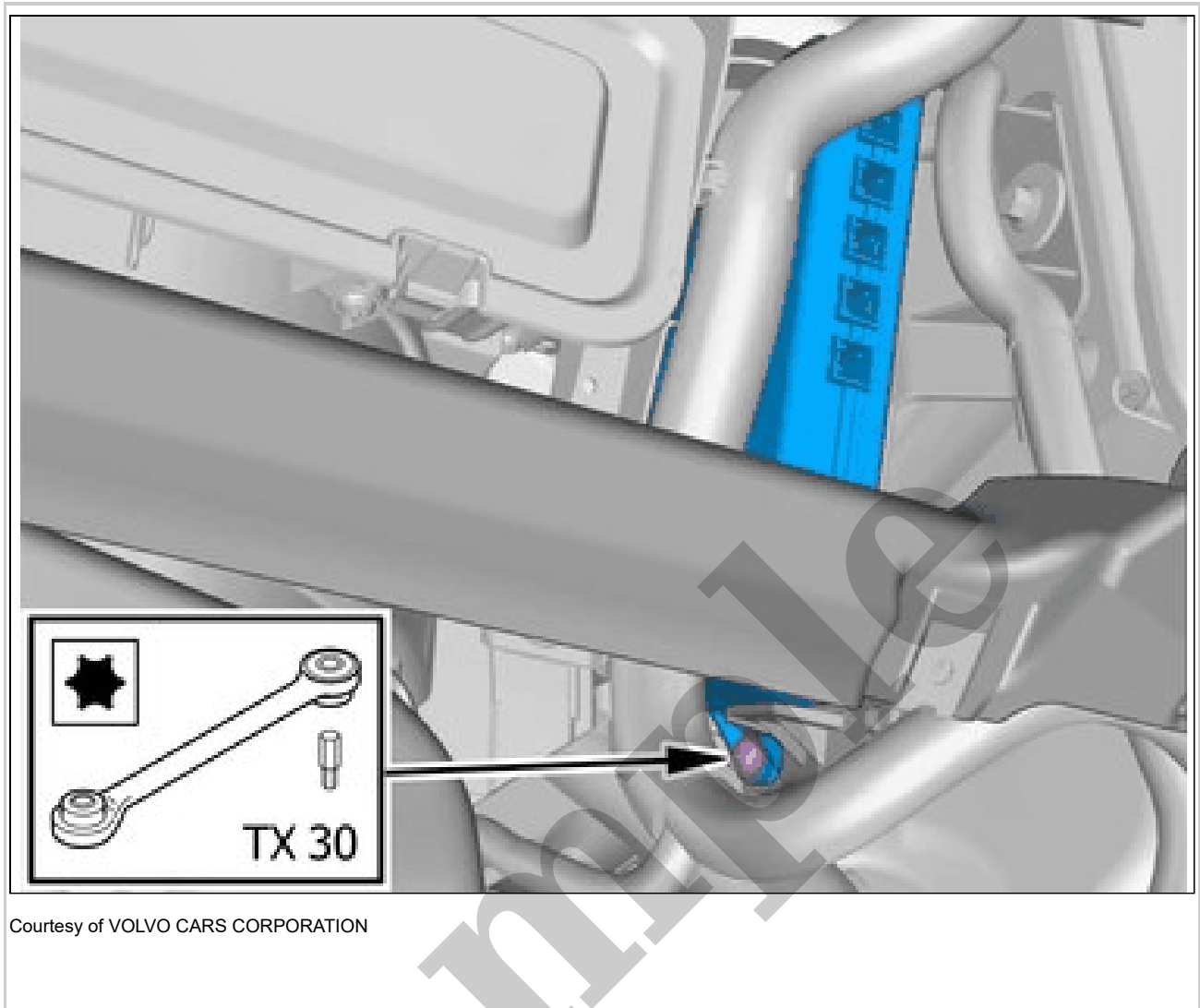

Courtesy of VOLVO CARS CORPORATION

Remove the screw.  
Remove the marked part.

## WIDE ANGLE VISION MODULE > WIDE ANGLE VISION MODULE (WAM) [2021-2022] > INSTALLATION

To install, reverse the removal procedure.

**NOTE:** *The following steps are only necessary when installing a new component.*

Order and download the appropriate software according to: VIDA/Software/Hardware Changes  
Calibrate WAM according to: Diagnostics / Components / Control modules /Wide Angle Vision Module (WAM) / Diagnostic sequences / Calibrating parking assistance cameras

## WIDE ANGLE VISION MODULE > WIDE ANGLE VISION MODULE (WAM) [2018-2020] > REMOVAL